

TUBELITE®

DEPENDABLE

**LEADERS IN ECO-EFFICIENT STOREFRONT,
CURTAINWALL AND ENTRANCE SYSTEMS**

400 4-SIDE SSG CASSETTE

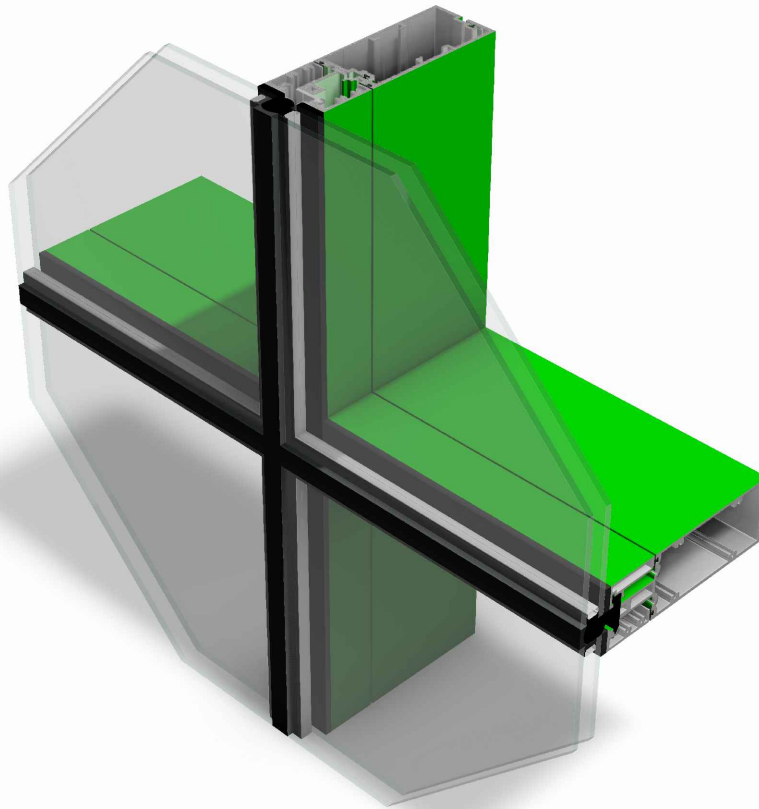

INSTALLATION INSTRUCTIONS with 400CW / T CURTAIN WALL

TUBELITE®

DEPENDABLE

LEADERS IN ECO-EFFICIENT STOREFRONT,
CURTAINWALL AND ENTRANCE SYSTEMS

BLANK

TABLE OF CONTENTS

GENERAL CONSTRUCTION NOTES	5 - 6
QUICK REFERENCE CHECKLIST	6
ELEVATION and DETAILS.....	7 - 14
FRAME EXTRUSIONS and ACCESSORIES.....	15 - 19
SUPPORT FRAME (400T) BACK MEMBER PREP.....	20 - 23
STANDARD CASSETTE FRAME	
FRAME SIZE CALCULATOR.....	24
FRAME CUT SIZE CALCULATOR and FRAME END PREP.....	25
CASSETTE GLASS SIZE CALCULATOR.....	26
CASSETTE FRAME ASSEMBLY.....	27
CASSETTE FRAME GLAZING.....	28 - 29
CASSETTE FRAME - "Glass-to-Edge" HEAD & JAMB	
FRAME SIZE CALCULATOR.....	30
FRAME CUT SIZE CALCULATOR and FRAME END PREP.....	31
CASSETTE GLASS SIZE CALCULATOR.....	32
CASSETTE FRAME ASSEMBLY.....	33
CASSETTE FRAME GLAZING.....	34 - 35
"Glass-to-Edge" HEAD & JAMB FRAME INSTALLATION SEQUENCE.....	36
CASSETTE FRAME - "Glass-to-Edge" HEAD ONLY	
FRAME SIZE CALCULATOR.....	37
FRAME CUT SIZE CALCULATOR and FRAME END PREP.....	38
CASSETTE GLASS SIZE CALCULATOR.....	39
CASSETTE FRAME ASSEMBLY.....	40
CASSETTE FRAME GLAZING.....	41 - 42
"Glass-to-Edge" HEAD FRAME INSTALLATION SEQUENCE.....	43
CASSETTE FRAME - "Glass-to-Edge" SILL ONLY	
FRAME SIZE CALCULATOR.....	44
FRAME CUT SIZE CALCULATOR and FRAME END PREP.....	45
CASSETTE GLASS SIZE CALCULATOR.....	46
CASSETTE FRAME ASSEMBLY.....	47
CASSETTE FRAME GLAZING.....	48 - 49
"Glass-to-Edge" SILL FRAME INSTALLATION SEQUENCE.....	50

TABLE OF CONTENTS - continued

CASSETTE FRAME - "Glass-to-Edge" SILL & JAMB	
FRAME SIZE CALCULATOR.....	51
FRAME CUT SIZE CALCULATOR and FRAME END PREP.....	52
CASSETTE GLASS SIZE CALCULATOR.....	53
CASSETTE FRAME ASSEMBLY.....	54
CASSETTE FRAME GLAZING.....	55 - 56
"Glass-to-Edge" SILL & JAMB FRAME INSTALLATION SEQUENCE.....	57
 CASSETTE FRAME - "Glass-to-Edge" JAMB ONLY	
FRAME SIZE CALCULATOR.....	58
FRAME CUT SIZE CALCULATOR and FRAME END PREP.....	59
CASSETTE GLASS SIZE CALCULATOR.....	60
CASSETTE FRAME ASSEMBLY.....	61
CASSETTE FRAME GLAZING.....	62 - 63
"Glass-to-Edge" JAMB FRAME INSTALLATION SEQUENCE.....	64
 OUTSIDE CORNER CASSETTE FRAME	
FRAME SIZE CALCULATOR.....	65
FRAME CUT SIZE CALCULATOR and FRAME END PREP.....	66
CASSETTE GLASS SIZE CALCULATOR.....	67
CASSETTE FRAME ASSEMBLY.....	68
CASSETTE FRAME GLAZING.....	69 - 70
 INSIDE CORNER CASSETTE FRAME	
FRAME SIZE CALCULATOR.....	71
FRAME CUT SIZE CALCULATOR and FRAME END PREP.....	72
CASSETTE GLASS SIZE CALCULATOR.....	73
CASSETTE FRAME ASSEMBLY.....	74
CASSETTE FRAME GLAZING.....	75 - 76
INSIDE CORNER FRAME INSTALLATION SEQUENCE.....	77
 STANDARD CASSETTE FRAME INSTALLATION SEQUENCE.....	78 - 79
TYPICAL ANCHOR PATTERN - Adjacent Frames.....	80
CASSETTE FRAME PERIMETER CLOSURE TRIM INSTALLATION (options 1 & 2).....	81 - 82
CASSETTE FRAME SEAL and PERIMETER SEAL INSTRUCTIONS.....	83
CASSETTE FRAME to CAPTURED DETAIL INSTRUCTIONS.....	84
CASSETTE DOOR FRAME PERIMETER DETAIL INSTRUCTIONS.....	85
 CASSETTE FRAME CUT DIMENSIONS / ASSEMBLY - INTERSTORY MOVEMENT APPLICATION	86 - 88
CASSETTE FRAME INSTALLATION - INTERSTORY MOVEMENT APPLICATION.....	89 - 96
 EXTERIOR ACCENT COVER INSTALLATION.....	97

GENERAL CONSTRUCTION NOTES

1. These instructions cover typical product application, fabrication, installation and standard conditions and are general in nature. They provide useful guidelines, but the final shop drawings may include additional details specific to the project. Any conflict or discrepancies must be clarified prior to execution.
2. Materials stored at the job site must be kept in a safe place protected from possible damage by other trades. Stack with adequate separation so materials will not rub together and store off the ground. Cardboard or paper wrapped materials must be kept dry. Check arriving materials for quantity and keep a record of where various materials are stored.
3. All field welding must be done in accordance with AISC guidelines. All aluminum and glass should be shielded from field welding to avoid damage from weld splatter. Results will be unsightly and may be structurally unsound. Advise general contractor and other trades accordingly.
4. Coordinate protection of installed work with general contractor and/or other trades.
5. Coordinate sequence of other trades which affect framing installation with the general contractor (e.g. fire proofing, back up walls, partitions, ceilings, mechanical ducts, HVAC, etc.).
6. General contractor should furnish and guarantee bench marks, offset lines and opening dimensions. These items should be checked for accuracy before proceeding with erection. Make certain that all adjacent substrate construction is in accordance with the contract documents and/or approved shop drawings. If not, notify the general contractor in writing before proceeding with installation because this could constitute acceptance of adjacent substrate construction by others.
7. Isolate all aluminum to be placed directly in contact with masonry or other incompatible materials with a heavy coat of zinc chromate or bituminous paint. Fasteners attaching framing to building structure are typically not provided by Tubelite.
8. Sealant selection is the responsibility of the erector, installer and/or glazing contractor and must be approved by the sealant manufacturer with regard to application and compatibility for its intended use. All sealants must be used in strict accordance with the manufacturer's instructions and applied only by trained personnel to surfaces that have been properly prepared.
9. Sealant must be compatible with all materials with which they have contact, including other sealant surfaces. Consult the sealant manufacturer for recommendations relative to shelf life, compatibility, cleaning of substrate, priming, tooling adhesion, etc. Recommend sealant manufacturer perform adhesion "pull test" at "wet" glazing for quality assurance.
10. Drainage gutters and weep holes must be kept clean at all times. Tubelite will not accept responsibility for improper drainage as a result of clogged gutters and weep holes.
11. This product requires clearances at the head, sill and jambs to allow for thermal expansion and contraction as well as construction tolerances. Refer to final distribution drawings for joint sizes. Joints smaller than 1/2" may be subject to failure. Consult the sealant manufacturer for proper sizing of joints.
12. All framing members, entrances and other materials are to be installed plumb, level and true with regard to established bench marks, column center lines or other working points established by the general contractor and checked by the erector, installer and/or glazing contractor.
13. After sealant is set and a representative amount of the wall has been glazed (500 square feet or more), run a water hose test to check installation. On large projects, a hose test should be repeated during glazing operation. This testing should be conducted in accordance with AAMA 501.2 specifications.
14. Cleaning of exposed aluminum surfaces should be done per AAMA recommendations.
15. Care must be taken when assembling aluminum framing components. Over tightening any fastener may cause stripping or fastener failure. Tubelite recommends the use of drill motors with clutches engaged to provide satisfactory tightening of the screw while preventing over torque. The use of impact drill motors is not recommended due to the absence of a clutch device.
16. Check www.tubeliteinc.com for any installation instruction updates.

GENERAL CONSTRUCTION NOTES

17. For cold weather installation, glazing materials (including but not limited to glazing gaskets, isolators and gaskets for air seals and expansion mullions) can become more rigid and thus more difficult to install. These materials should be installed at temperatures above 40 degrees Fahrenheit for proper system performance and ease of installation. A hot box may be required to warm the glazing materials prior to installation. Allow glazing materials to lay flat at 50 degrees Fahrenheit minimum temperature prior to installing.

400CW/T ASSEMBLY AND INSTALLATION

Refer to Tubelite, Inc website (tubeliteinc.com) for 400CW/T curtain wall installation instructions.

1. Make sure the opening is square and the perimeter from edge of frame to substrate is 1/2" minimum clearance.
2. Sealant at Horizontal to Vertical frame intersection is not required where Cassette framing will be installed.
3. Water dam installation is not required where Cassette framing will be installed.
4. Check anchor size and location against installation instructions or approved shop drawings.

QUICK REFERENCE CHECKLIST

1. Review slide-n-pivot jamb anchor installation: Pre-load in jamb framing prior to assemble OR mill slot in jamb framing to install slide-n-pivot jamb anchor after cassette frame assembly.
2. Field verify DLO of installed curtain wall prior to cassette frame machining and assembly.
3. Each cassette type has its own sequence of pages for size determination to installation phase.
4. Cassette frames can be installed in vertical runs, horizontal runs or shingled. If spot frame installation is require then head / jamb slide-n-pivot anchor clips must be used at sill also.
5. Sill / Head-Sill slide-n-pivot anchor design for "rollover" cassette installation.
6. Install P4216 PVC perimeter isolator prior to cassette frame installation.
7. Install P4209 gasket prior to cassette frame installation.
8. Install all Outside and Inside corner frame inserts prior to cassette frame installation.
9. Install inside corner cassette frame prior to installation of adjacent cassette frames.

NOTE: Refer to pages 80 -82 for perimeter trim closure installation. Option two requires vertical members to have stem removed 1" from both ends head and sill. This will need to be completed prior to frame installation.

FRAME SIZE CALCULATION

Refer to individual cassette frame types for cassette frame size calculator

GLASS SIZE CALCULATION

Refer to individual cassette frame types for cassette glass size calculator

NOTE: Tubelite Inc is not responsible for glass to frame installation, approval of glass to frame installation or materials used for glass to frame installation.

It is the glazing contractors responsibility to obtain approval from glass manufacturer for glass installation.

Finished sections of cassette framing may need to be sent to sealant manufacture for adhesion testing and approval.

3M VHB TAPE APPLICATION GLAZING

Approved shop drawings showing frame sizes and frame installation, AND finished sections of the cassette framing are required to be sent to 3M for review and approval prior to purchasing tape or glazing commences. Glazing contractor will be required to be trained and certified by qualified 3M personnel prior to VHB tape application or glass installation.
(See 3M website for contact information)

DETAIL REFERENCE ELEVATION

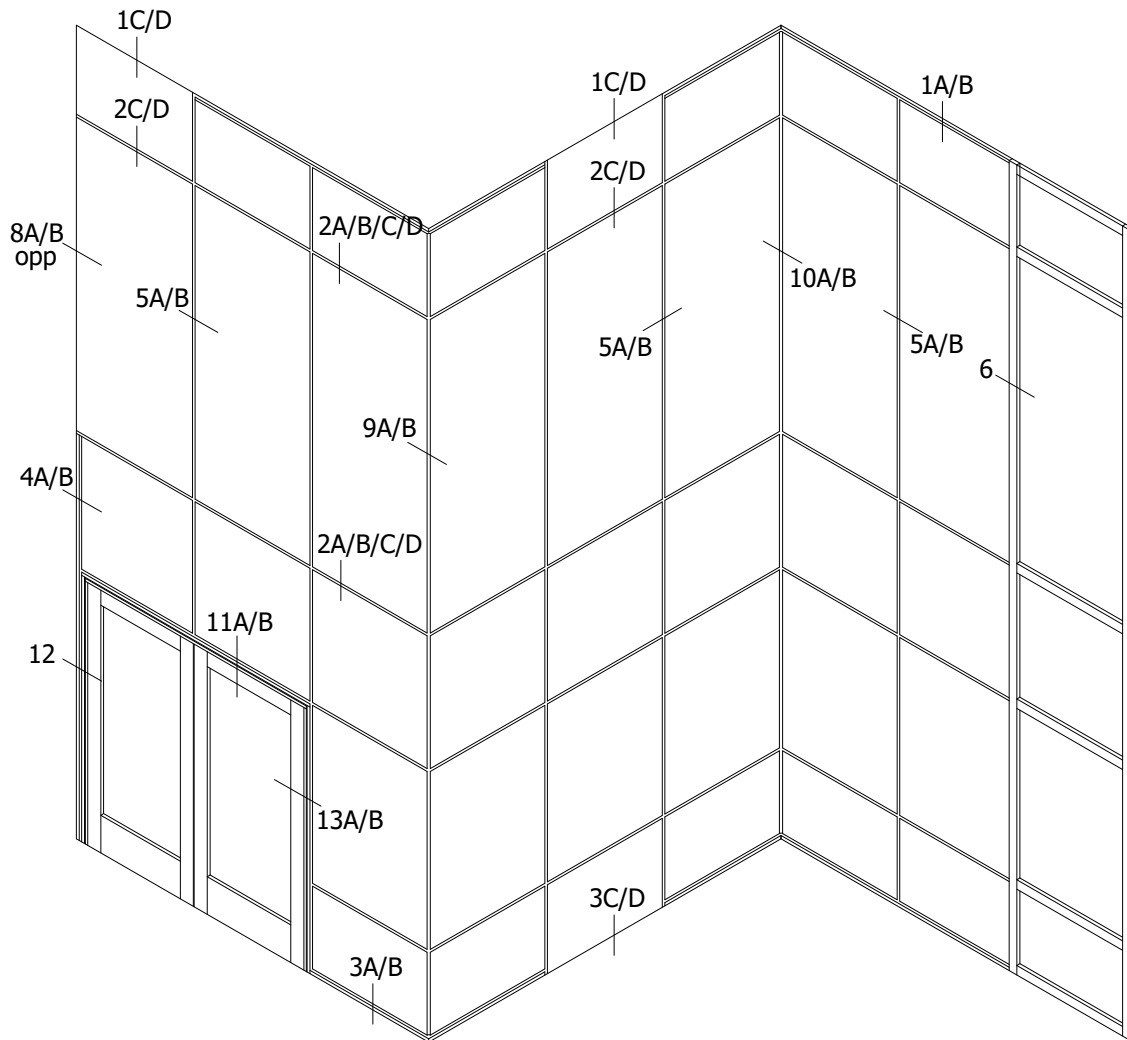

TYPICAL ELEVATION

HORIZONTAL DETAILS

1A

STANDARD

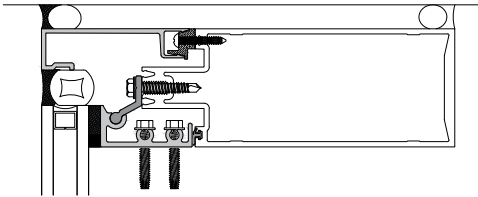

1B

OPTIONAL
3M VHB TAPE

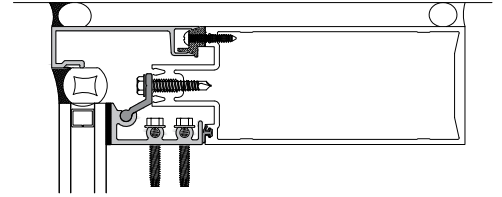

2A

STANDARD

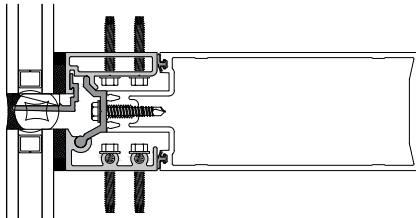

2B

OPTIONAL
3M VHB TAPE

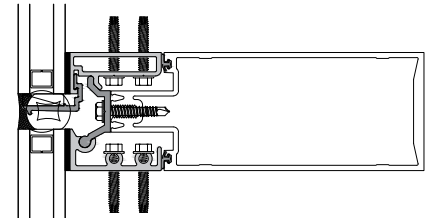

2C

HORIZONTAL EXPANSION
SILICONE GLAZED

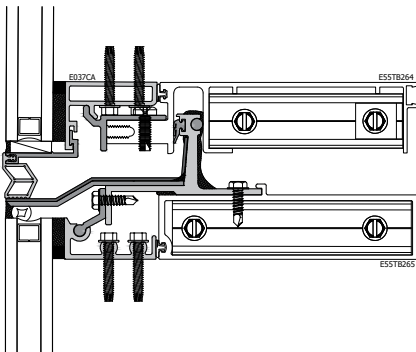

2D

OPTIONAL
HORIZONTAL EXPANSION
3M VHB TAPE

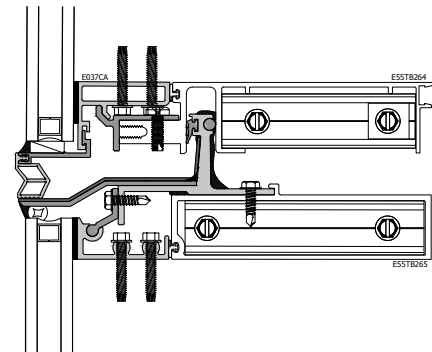

3A

STANDARD

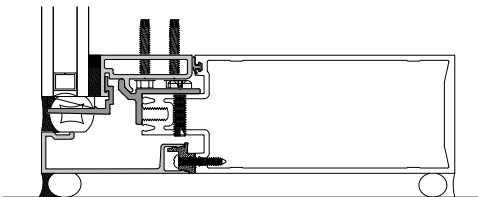

3B

OPTIONAL
3M VHB TAPE

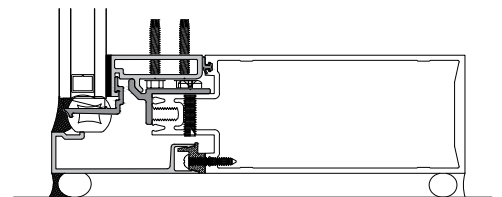

HORIZONTAL DETAILS

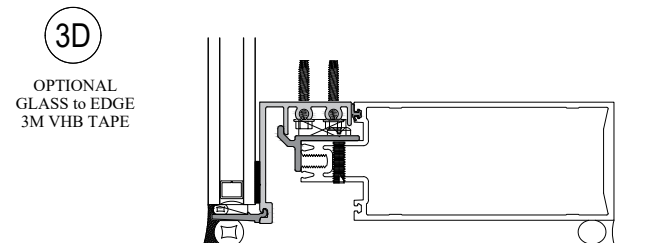
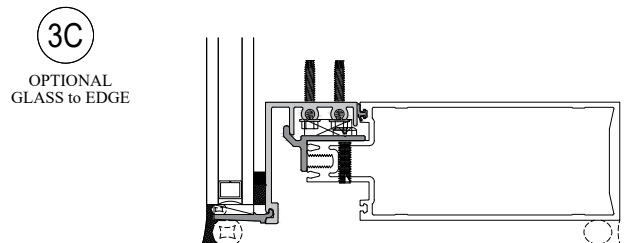
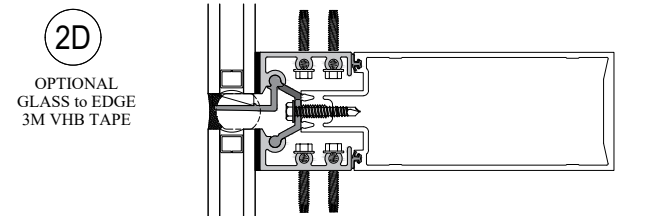
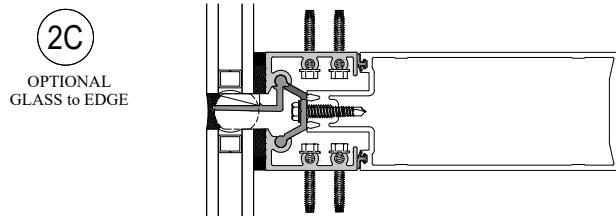
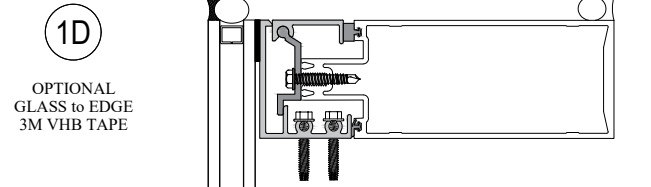
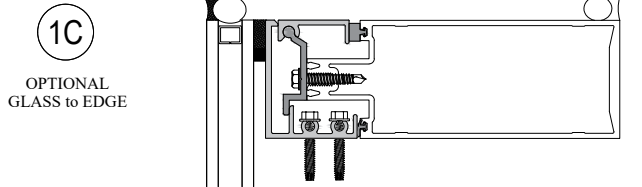

VERTICAL DETAILS

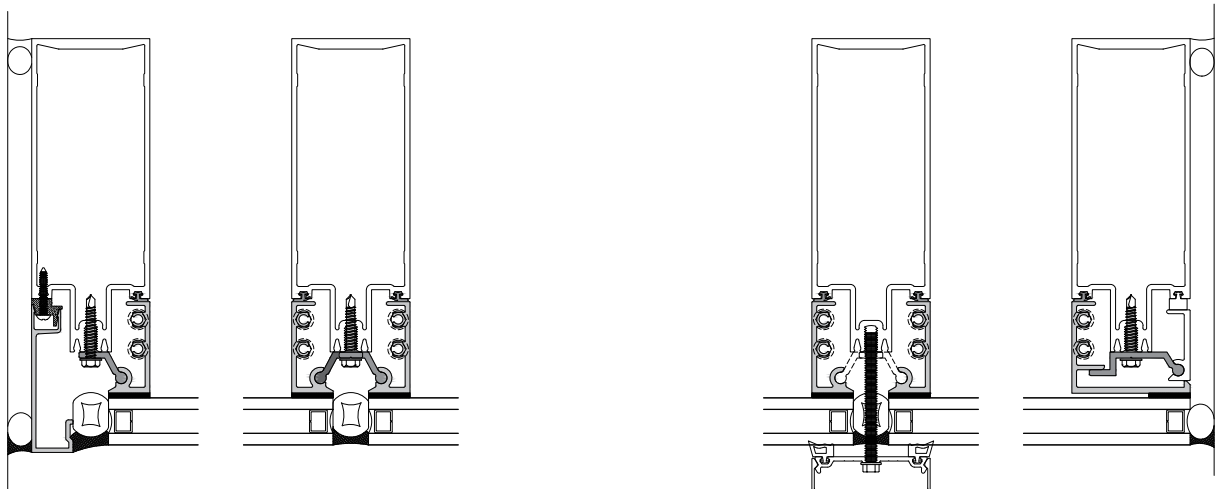
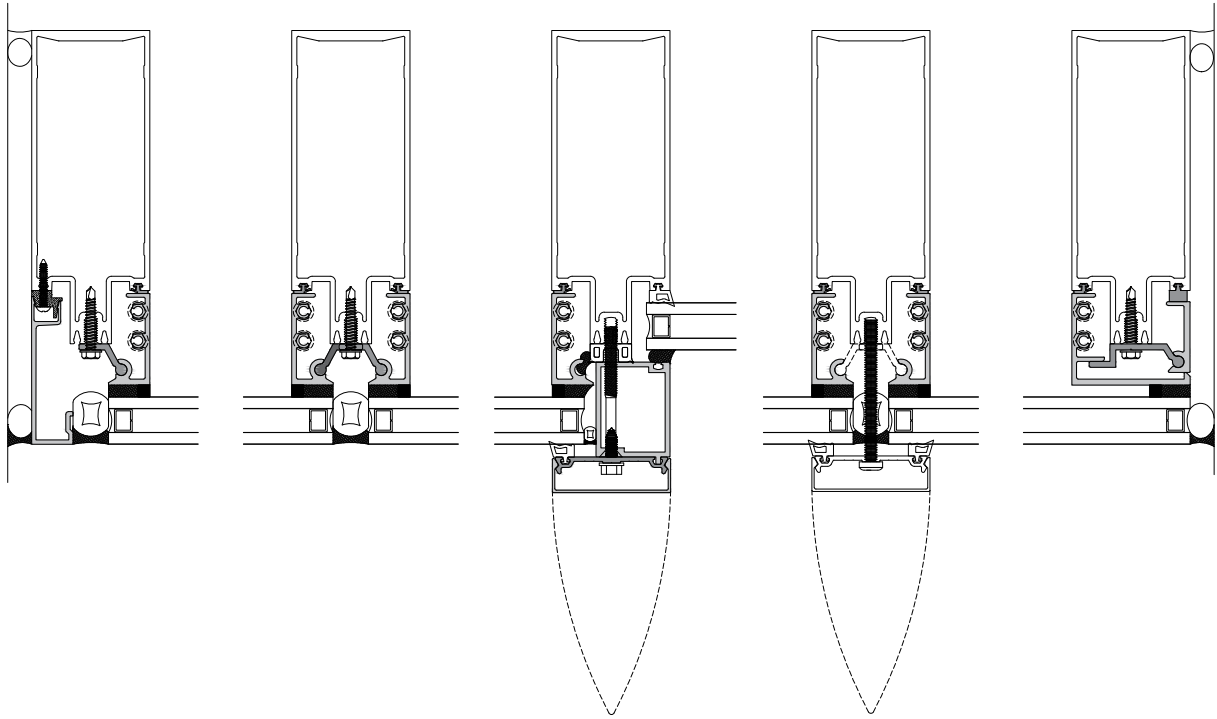

4B

OPTIONAL JAMB
3M VHB TAPE

5B

OPTIONAL
STANDARD VERTICAL
3M VHB TAPE

7B

OPTIONAL
VERTICAL COVER
3M VHB TAPE

8B

OPTIONAL
GLASS to EDGE
3M VHB TAPE

OUTSIDE 90 DEGREE CORNER DETAILS

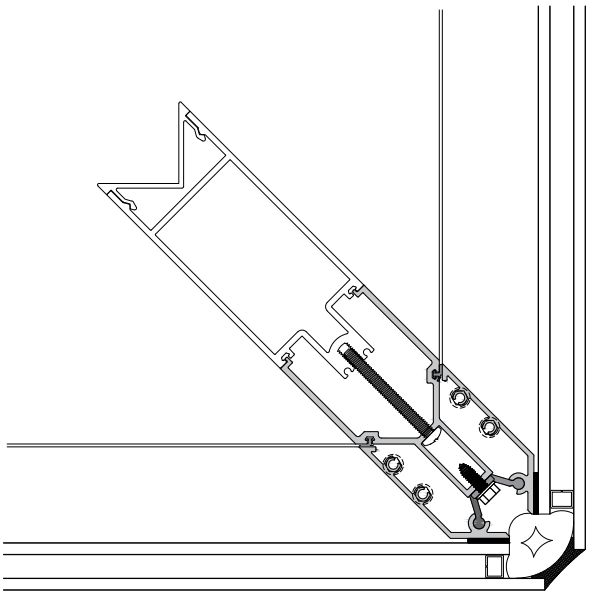
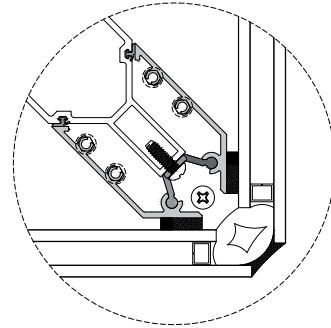
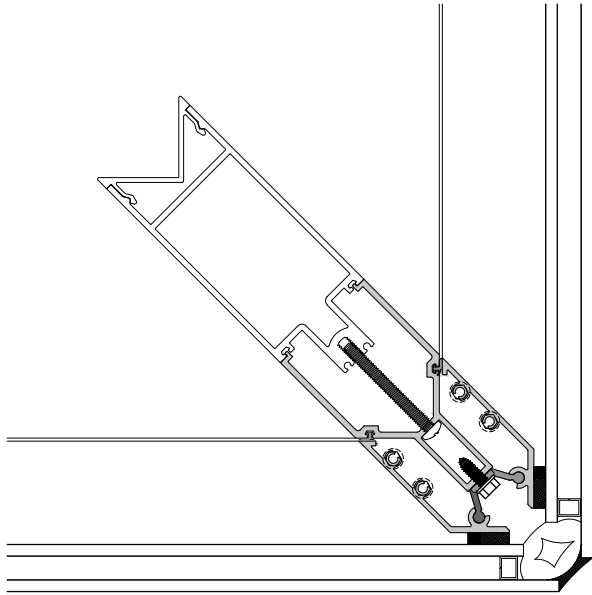

INSIDE 90 DEGREE CORNER DETAILS

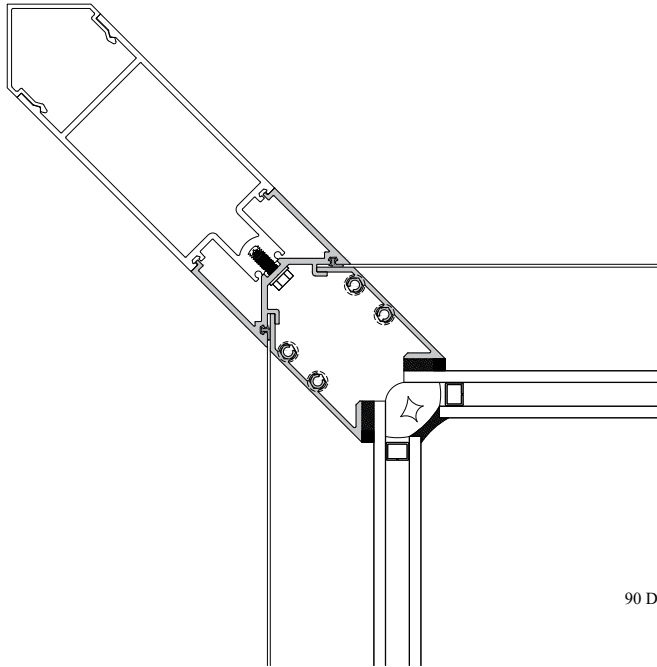

10A

STANDARD
90 DEGREE IS SSG CORNER

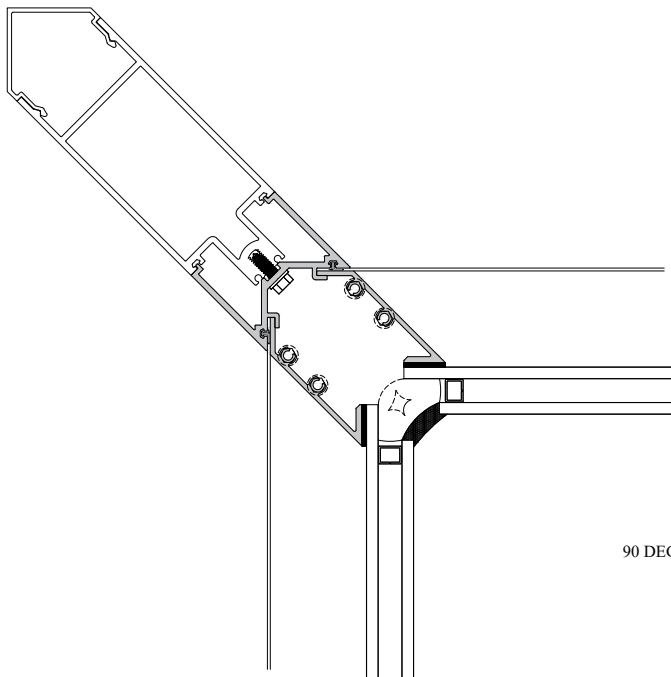

10B

OPTIONAL
90 DEGREE IS SSG CORNER
3M VHB TAPE

HORIZONTAL DETAILS

11A

STANDARD DOOR TRANSOM

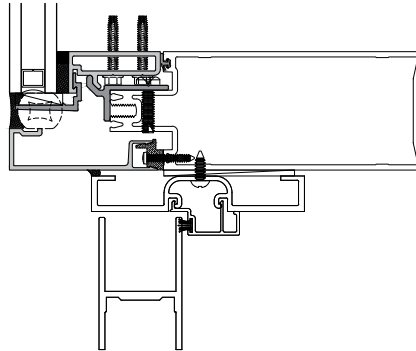

11B

OPTIONAL DOOR TRANSOM
3M VHB TAPE

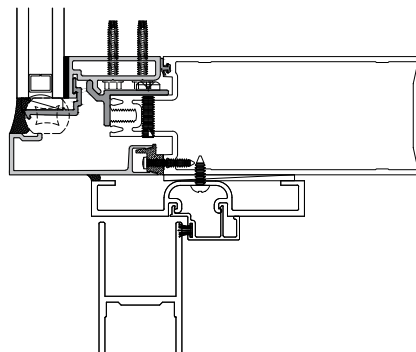

HORIZONTAL DETAILS

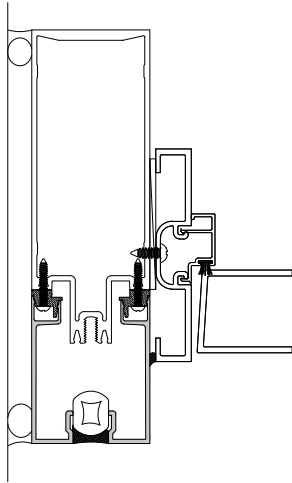

12

STANDARD DOOR JAMB

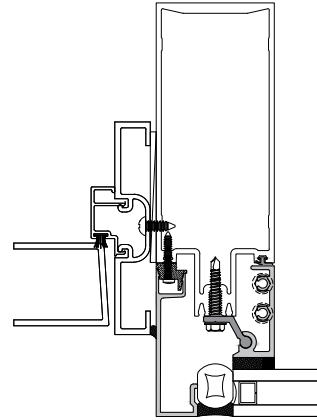

13A



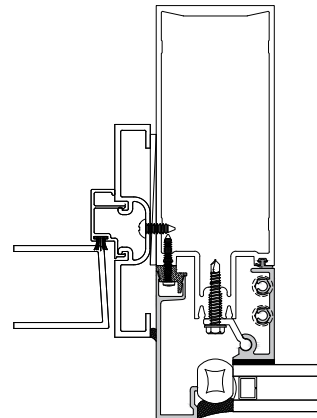

STANDARD
DOOR INTERMEDIATE





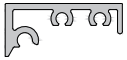
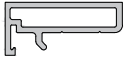

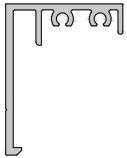
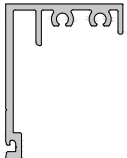
13B

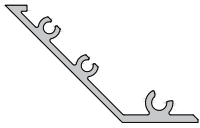
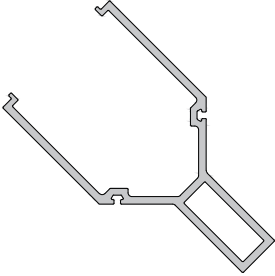
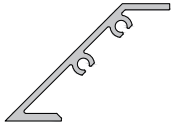
OPTIONAL
DOOR INTERMEDIATE
3M VHB TAPE



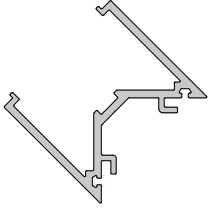
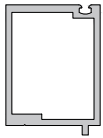
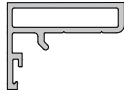
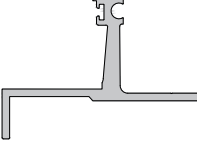
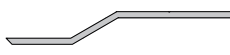
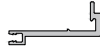







TYPICAL FRAMING EXTRUSIONS

SHAPE	DESCRIPTION	Part No.	Stock Length
	CASSETTE FRAME HEAD / JAMB	E001CA	290"
	CASSETTE FRAME SILL	E002CA	290"
	CASSETTE PERIMETER CLOSURE	E004CA	290"
	CASSETTE "GLASS-to-EDGE" HEAD / JAMB	E009CA	290"
	CASSETTE "GLASS-to-EDGE" SILL	E010CA	290"
	CASSETTE "GLASS-to-EDGE" BACK UP FRAME HEAD / JAMB / SILL	E011CA	290"
	CASSETTE 90 DEGREE OS SSG CORNER FRAME	E017CA	290"
	CASSETTE 90 DEGREE OS SSG CORNER INSERT	E020CA	290"
	CASSETTE 90 DEGREE IS SSG CORNER FRAME	E023CA	290"

TYPICAL FRAMING EXTRUSIONS

SHAPE	DESCRIPTION	Part No.	Stock Length
	CASSSETTE 90 DEGREE IS SSG CORNER INSERT	E026CA	290"
	CASSSETTE to CAPTURED TRANSITION INSERT	E033CA	290"
	CASSSETTE FRAME SILL EXTENDED HORIZONTAL EXPANSION	E037CA	290"
	HORIZONTAL EXPANSION "CHICKEN HEAD" FRAME	E038CA	290"
	HORIZONTAL EXPANSION "CHICKEN HEAD" SILL EXTENSION	E039CA	290"
	CONTINUOUS SETTING BLOCK CHAIR with RECEIVER FOR PTB134 GASKET	E040CA	290"
	CASSSETTE to CAPTURED TRANSITION PRESSURE PLATE	M4TB224	290"
	CASSSETTE to CAPTURED TRANSITION ALUMINUM COVER	E4TB64	290"
	POLYURETHANE PRESSURE PLATE	PTB120	290"

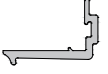
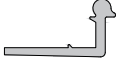







TYPICAL EXTRUDED ACCESSORIES

SHAPE	DESCRIPTION	Part No.	Stock Length
	CASSETTE SLIDING / PIVOT ANCHOR HEAD / JAMB / SILL	P4200	1-1/2"
	CASSETTE SLIDING / PIVOT DEAD LOAD ANCHOR SILL	P4202	2-1/2"
	CASSETTE SLIDING / PIVOT ANCHOR GLASS-to-EDGE HEAD / JAMB	P4204	1-1/2"
	CASSETTE SILL SETTING BLOCK CHAIR - E002CA	P4215	6"
	CASSETTE PERIMETER CLOSURE PVC THERMAL ISOLATOR (E004CA)	P4216	144"
	CASSETTE SILL SETTING BLOCK CHAIR GLASS-to-EDGE TOP ASSEMBLED PANEL	P4217	6"
	CASSETTE SILL SETTING BLOCK CHAIR GLASS-to-EDGE SILL	P4623	6"
	CASSETTE DEAD LOAD ANCHOR SILL	P4222	2-1/2"
	CASSETTE SILL SETTING BLOCK CHAIR - E002CA - VHB TAPE GLZ.	P4224	6"
	CASSETTE SILL SETTING BLOCK CHAIR GLASS-to-EDGE TOP ASSEMBLED PANEL - VHB TAPE GLZ.	P4225	6"
	CASSETTE SILL SETTING BLOCK CHAIR GLASS-to-EDGE SILL - VHB TAPE GLZ.	P4226	6"

ACCESSORIES - GASKETS / SETTING BLOCKS

SHAPE	DESCRIPTION	Part No.	Stock Length
	3/8" SILICONE THERMAL SEPARATOR GASKET	PTB108	250' per roll
	1/4" x 1/4" NOTON GLAZING TAPE ADHESIVE ONE SIDE	P4211	250' per roll
	1/4" x 1" SILICONE GLASS SETTING BLOCK	P1912S	4" each 100 per pk.
	7/16" x 1" SILICONE GLASS SETTING BLOCK DEAD LOAD GLASS-to-EDGE SILL	P4212	4" each 20 per pk
	1/4" x 7/8" SILICONE GLASS SETTING BLOCK DEAD LOAD GLASS-to-EDGE SILL	P4603	4" each 20 per pk
	1/4" x 3/8" SILICONE GASKET	P4209	250' per roll
	1/16" x 3/8" SILICONE FIN GASKET	P4227	250' per roll
	1/4" SILICONE GLAZING GASKET	P4606	250' per roll
	"3 FINGER" SWEEP GASKET FRONT OF CHICKEN HEAD	PTB116	500' per roll
	PVC SPACER ROD BACK SIDE OF CHICKEN HEAD	PTB117C	120" each pc.
	HORIZONTAL EXPANSION GASKET CHICKEN HEAD	PTB134	120" each pc.
	RETICULATED FOAM BAFFLE CHICKEN HEAD	P4810	20 per package

ACCESSORIES - FASTENERS

SHAPE	DESCRIPTION	Part No.	Stock Length
	#12 x 1-1/4" HWH SS TYPE F CASSETTE FRAME ASSEMBLY	S375	QTY = 100
	1/4-20 x 1-1/2" SELF-DRILLER CASSETTE ANCHOR FASTENER	S376	QTY = 100
	#8 x 1" PH PAN HD PVC THERMAL ISOLATOR FST.	S377	QTY = 50
	1/4-20 X 1" HWH SS TYPE F PRESSURE PLATE TRANSITION FST.	S455	QTY = 50
	1/4-20 X 2-3/4" PH FL HD SS MS TRANSITION INSERT FASTENER	S380	QTY = 50
	1/4-20 X 1" PH PAN HD ZINC #23 SILL STARTER ANCHOR FASTENER	S292	QTY = 50
	1/4-20 X 2-1/2" PH PAN HD ZINC OUTSIDE CORNER INSERT FST.	S473	QTY = 25
	1/4-20 X 1" HWH SS 18-8 CHICKEN HEAD TO FRAME FASTENER	S457	QTY = 100

**SUPPORT FRAME (400T BACK MEMBER) FRAME PREPARATION
FOR CASSETTE INSTALLATION and ANCHORAGE**

- REFER TO 400CW/T INSTALLATION MANUAL for CURTAIN WALL
BACK MEMBER ASSEMBLY AND ANCHORAGE.

Note: water dams, typical gasket, pressure plates and covers not required.

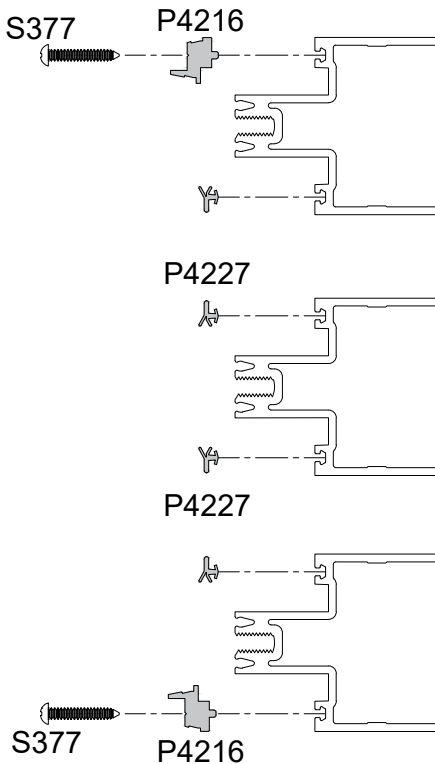
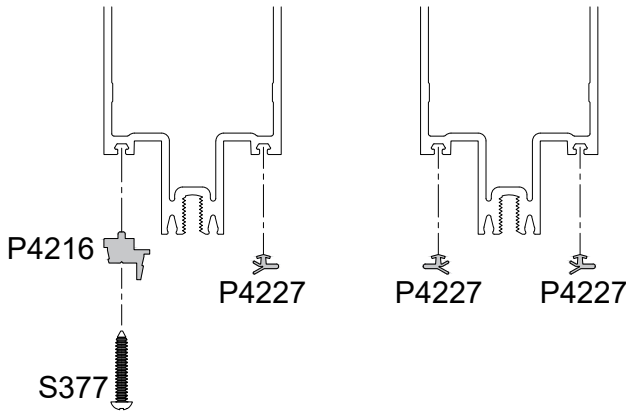
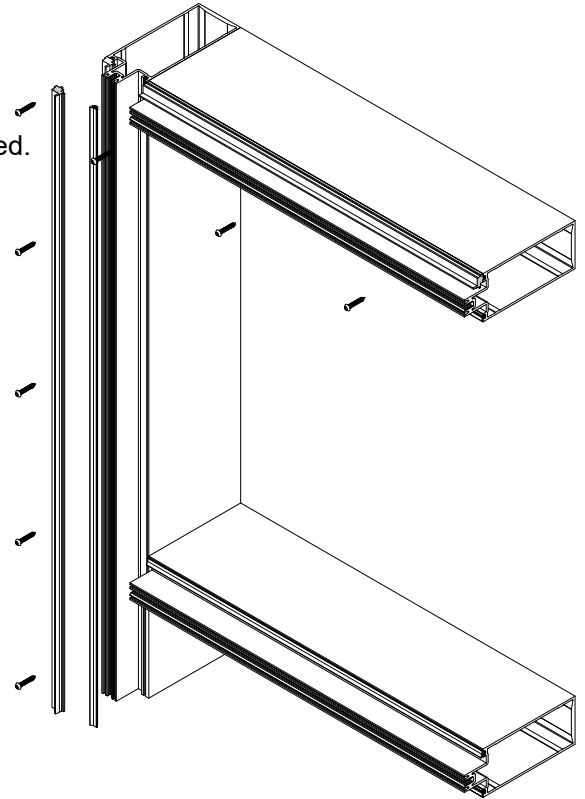

STEP 1: Install P4216 around perimeter framing, secure with S377 - hole pre-drilled 8" o/c. Locate fasteners no more than 2" from ends. Clean drill burrs prior to installing. Clean cut end burrs and align adjacent lineals.

STEP 2: Install spacer gasket P4227 at ALL vertical and horizontal framing members that will receive cassette framing. Leave long at ends as gasket will shrink back - trim gasket prior to cassette installation.

STEP 3: Install starter / anchoring clip P4223 12" o/c with S292 self-tapping fastener. End clips no more 2" from ends of sill members.

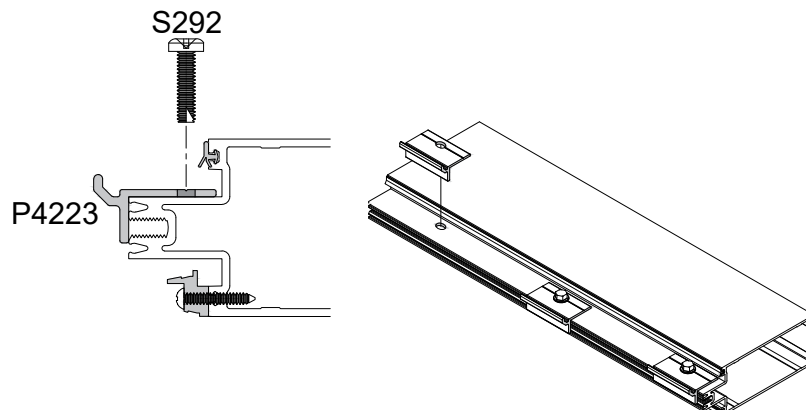

**SUPPORT FRAME (400T BACK MEMBER) FRAME PREPARATION
FOR CASSETTE INSTALLATION and ANCHORAGE
OUTSIDE CORNERS**

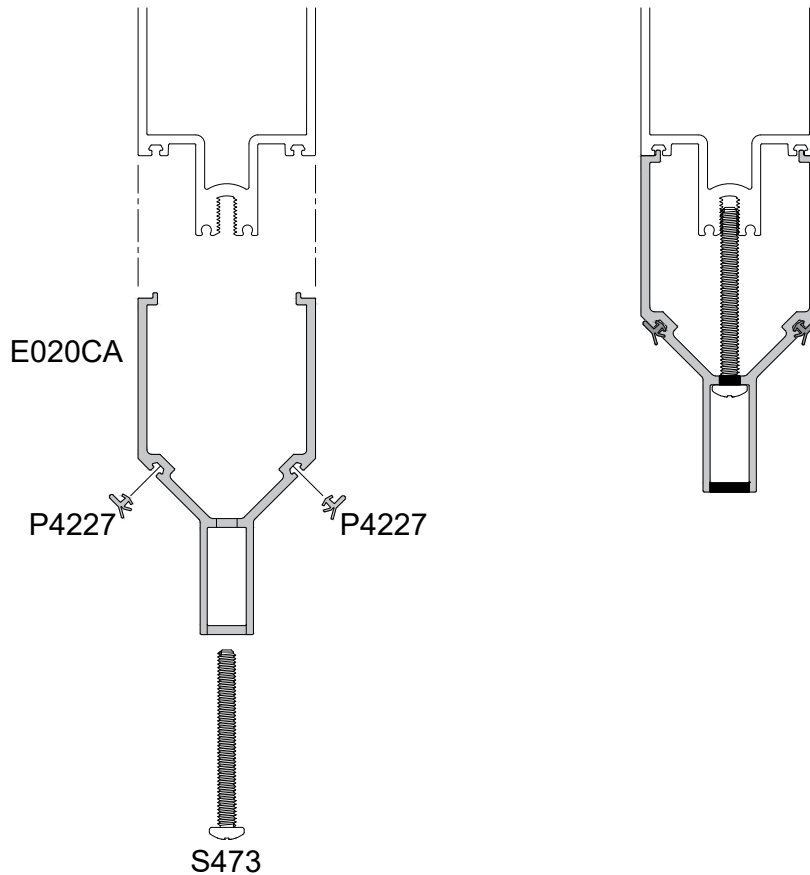

OUTSIDE CORNER FRAME PREP -

- STEP 1: Drill clearance holes and anchorage holes 18" o/c in E020CA corner insert. End holes no more than 2" from ends of extrusions.
- STEP 2: Attach E020CA to corner frame back member using S376 HX HD MS.
- STEP 3: Complete outside corner prep by installing P4227 spacer gasket. Leave gasket long at ends as gasket will shrink back - trim gasket prior to cassette frame installation.

**SUPPORT FRAME (400T BACK MEMBER) FRAME PREPARATION
FOR CASSETTE INSTALLATION and ANCHORAGE
INSIDE CORNERS**

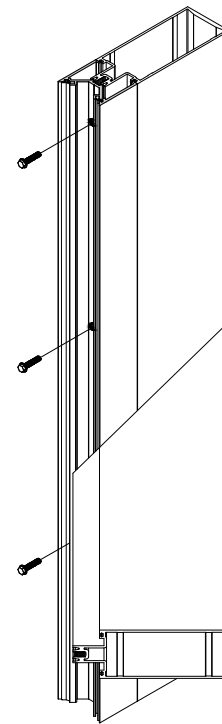
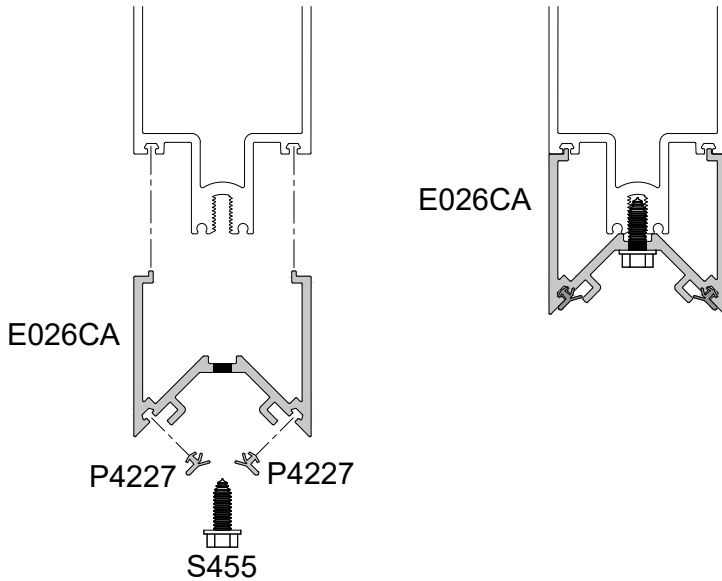

INSIDE CORNER FRAME PREP -

- STEP 1: Drill clearance holes and anchorage holes 18" o/c in E026CA corner insert. End holes no more than 2" from ends of extrusions.
- STEP 2: Attach E026CA to corner frame back member using S455 HX HD type F.
- STEP 3: Complete inside corner prep by installing P4227 spacer gasket. Leave gasket long at ends as gasket will shrink back - trim gasket prior to cassette frame installation.

**SUPPORT FRAME (400T BACK MEMBER) FRAME PREPARATION
 FOR CASSETTE INSTALLATION and ANCHORAGE
 "Glass-to-Edge" - JAMB, HEAD & SILL**

"Glass-to-Edge JAMB FRAME PREP -

STEP 1: Install anchor clip P4204 12" o/c using fastener S376 - No more than 2" from ends of DLO.

STEP 2: Complete "Glass-to-Edge jamb prep by installing P4227 spacer gasket. Leave gasket long at ends as gasket will shrink back - trim gasket prior to cassette frame installation.

NOTE: Install 24" piece of E011CA and 24" piece of P4209 at center line of jambs at cassette frames spanning more than 72" and design loads above 50 PSF

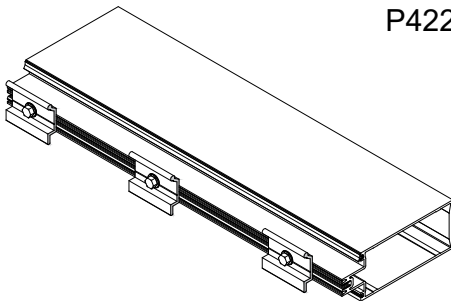
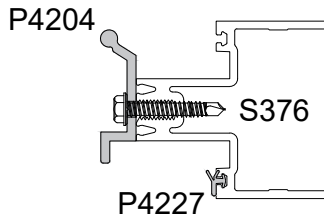
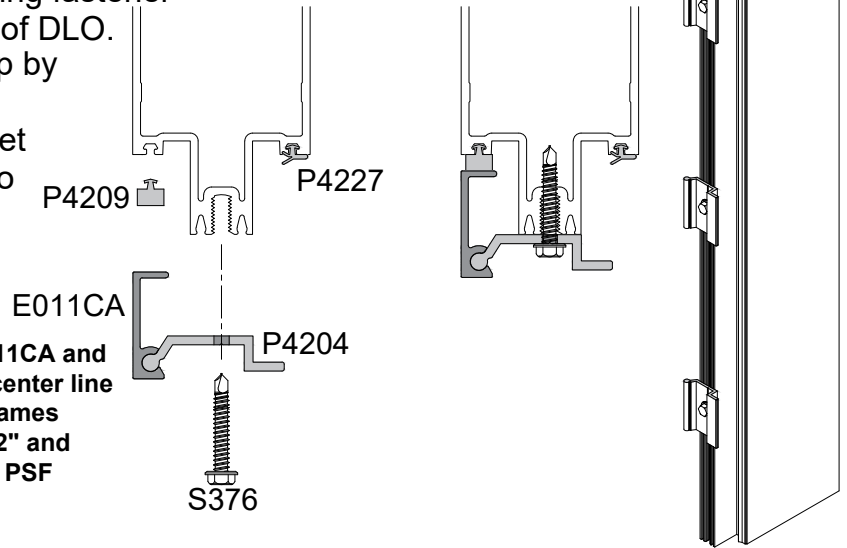

"Glass-to-Edge HEAD FRAME PREP -

STEP 1: Install anchor clip P4204 12" o/c using fastener S376 - No more than 2" from ends of DLO.

STEP 2: Complete "Glass-to-Edge head prep by installing P4227 spacer gasket. Leave gasket long at ends as gasket will shrink back - trim gasket prior to cassette frame installation.

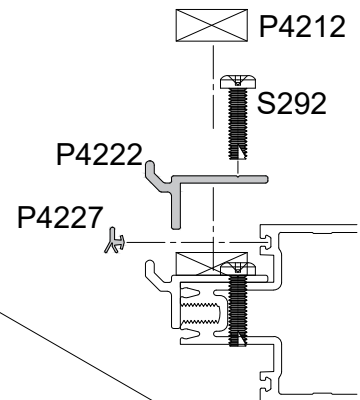

"Glass-to-Edge SILL FRAME PREP -

STEP 1: Install anchor clip P4222 12" o/c using fastener S292 - No more than 2" from ends of DLO.

STEP 2: Install silicone dead load block P4212 locating between P4222 anchor clip.

STEP 3: Complete "Glass-to-Edge jamb prep by installing P4227 spacer gasket. Leave gasket long at ends as gasket will shrink back - trim gasket prior to cassette frame installation.

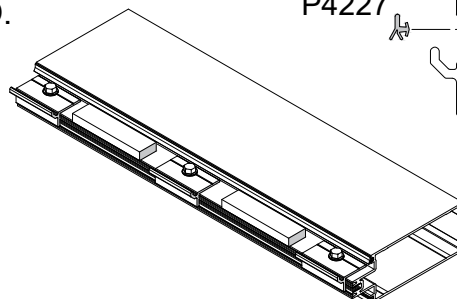

CASSETTE FRAME SIZE CALCULATOR - TYPICAL FRAMING

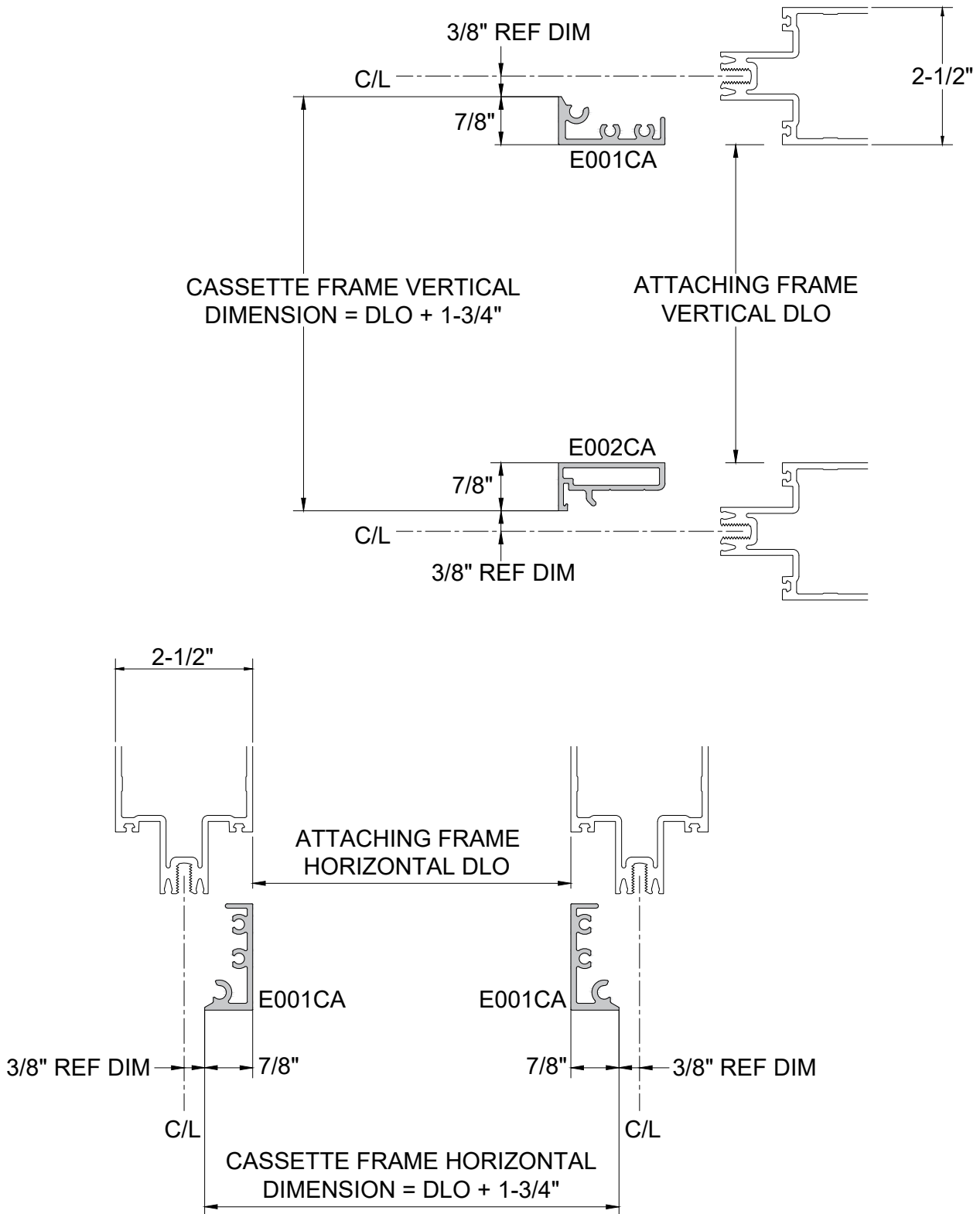

NOTE: Cassette frames sizes based on 400CW/T back members or 2-1/2" profile back members.

CASSETTE CUT SIZE CALCULATOR - TYPICAL FRAMING

Cassette frame member Vertical / Horizontal cut size:

Vertical frame member cut size = DLO of attaching frame

Horizontal frame member cut size = DLO plus 1-3/4" of attaching frame

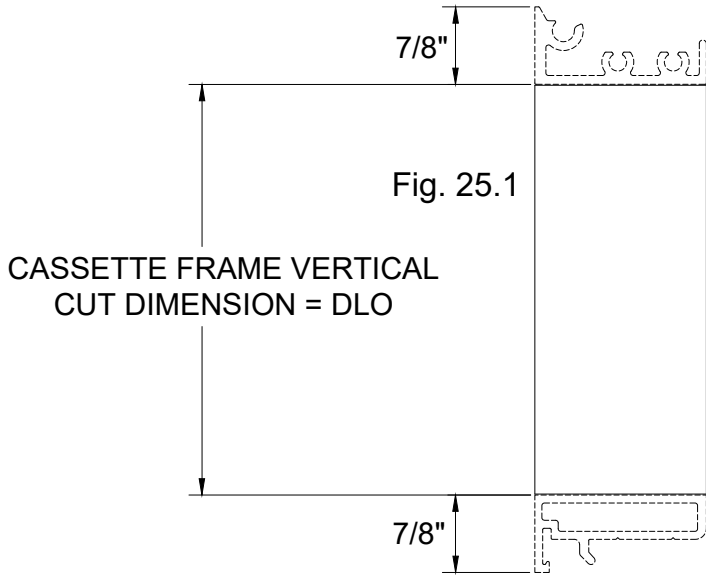

VERTICAL FRAME SIZE CALCULATOR

- STEP 1: Cut vertical (jamb) frame E001CA to calculated vertical cut size, Fig. 25.1.
- STEP 2: Cut horizontal head frame E001CA to calculated cut size mitering each end 11 degrees each end as shown at Fig. 25.2.
- STEP 3: Cut horizontal sill frame E002CA to calculated cut size mitering each end 11 degrees each end as shown at Fig. 25.2.

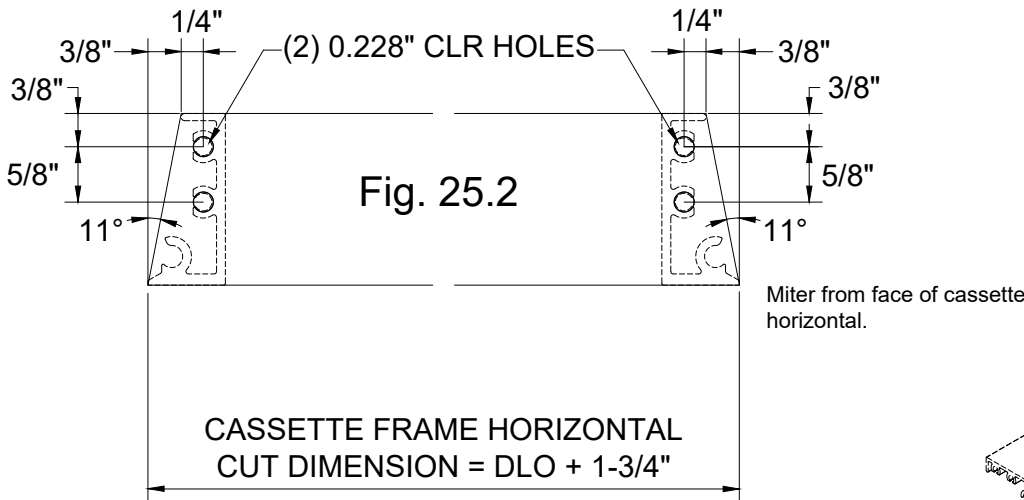

HORIZONTAL FRAME CUT and LAYOUT SECTION
 Standard Framing

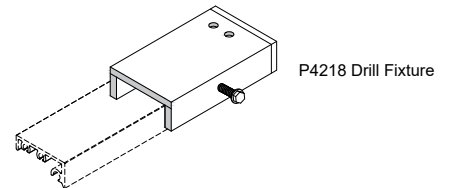

Assemble hole location as outlined below or drill fixture P4218 is available to assist with assemble hole location.

CASSETTE GLASS SIZE CALCULATOR - TYPICAL FRAMING

Cassette frame overall glass size:

Vertical glass size = Back member DLO plus 1-3/4"

Horizontal glass size = Back member DLO plus 1-3/4"

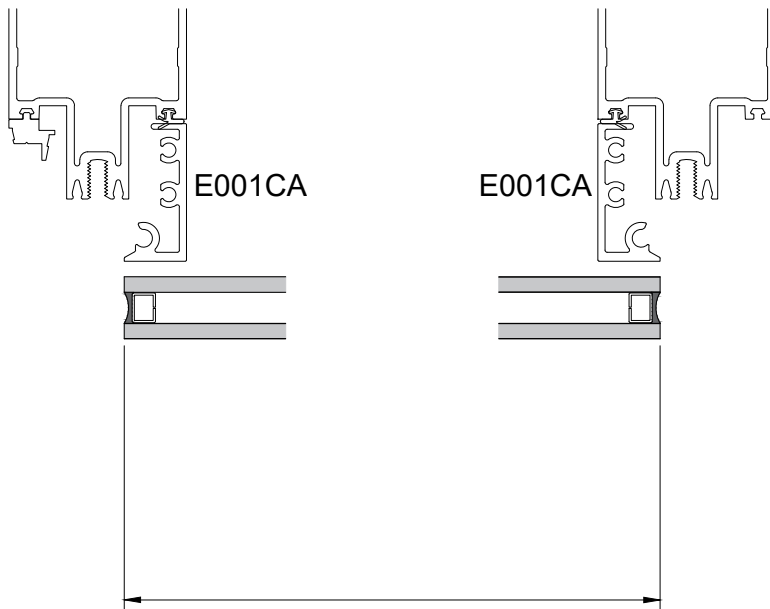
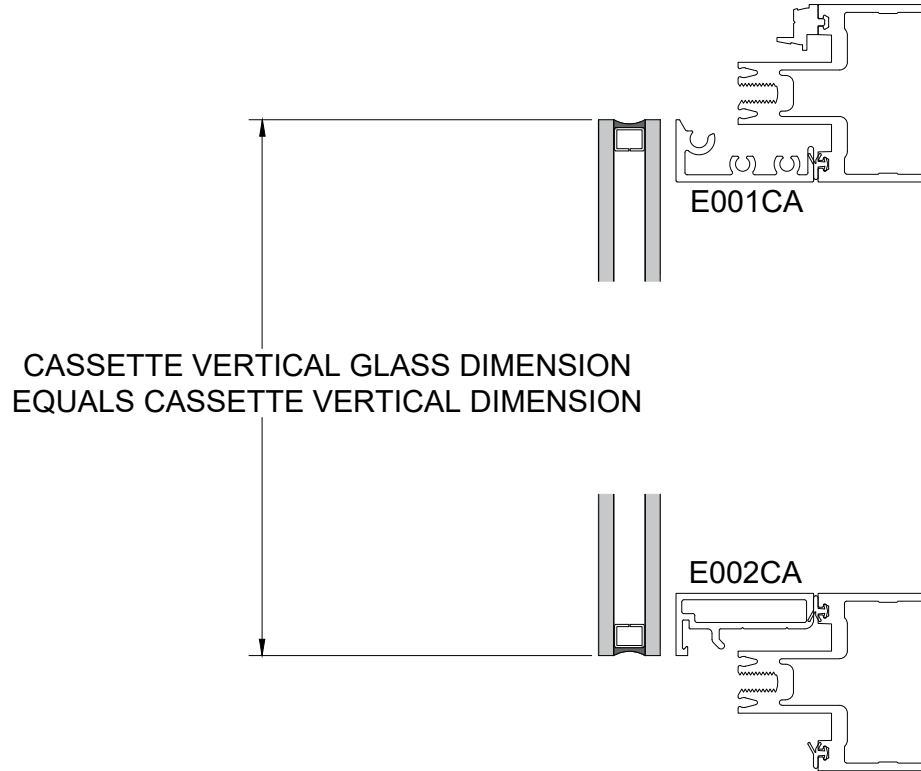

CASSETTE HORIZONTAL GLASS DIMENSION
EQUALS CASSETTE HORIZONTAL DIMENSION

CASSETTE FRAME ASSEMBLY- TYPICAL FRAMING

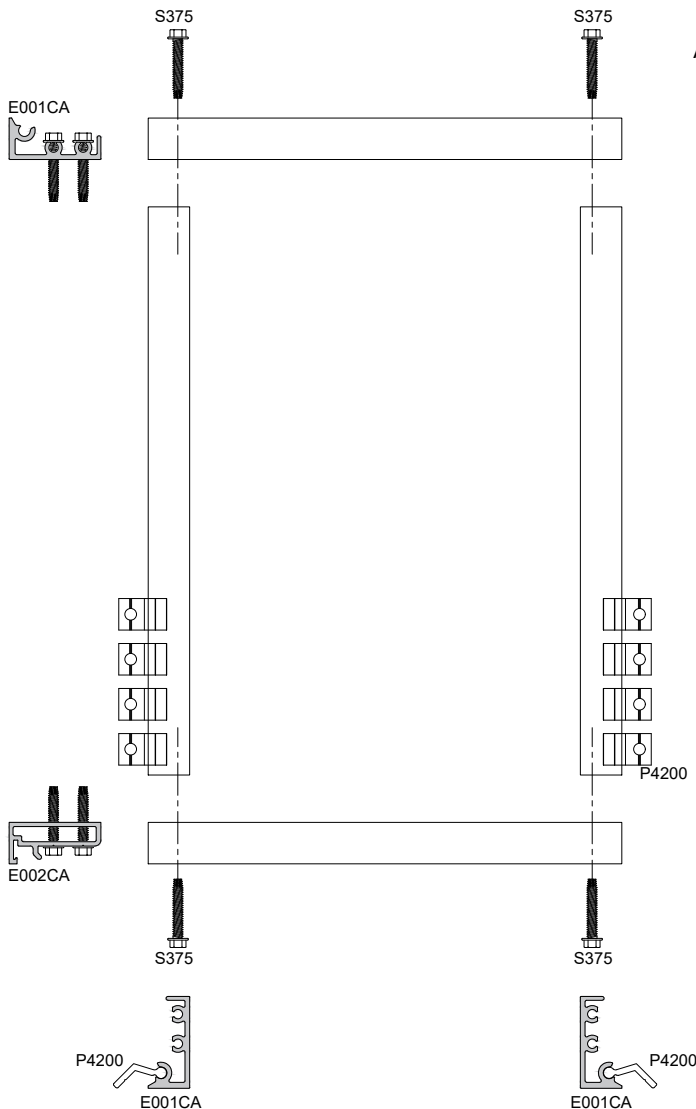

ALTERNATE JAMB ANCHOR INSTALLATION



If the P4200 anchors are to be loaded in the jambs after the cassette frame had been assembled, the contractor will need to remove the portion of the anchor receiver at the head of the jamb frames as shown above.

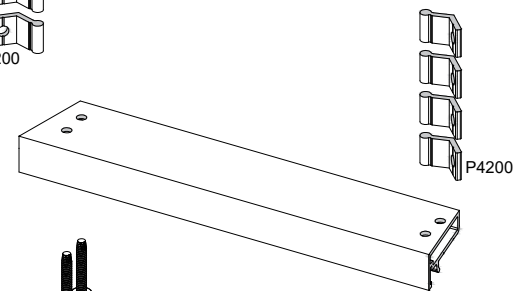
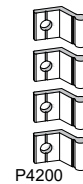
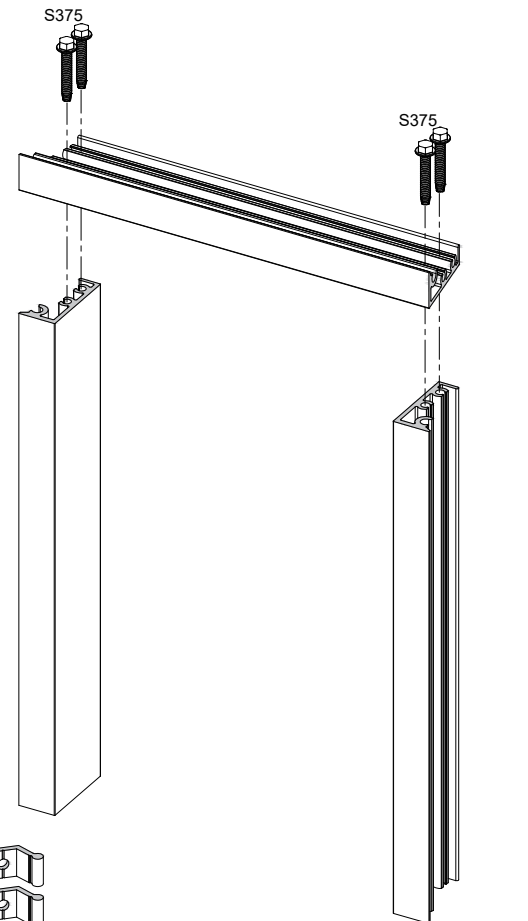

CASSETTE FRAME ASSEMBLY:

- STEP 1: Layout head, sill and jambs on table for assembly.
- STEP 2: Attach sill frame to jamb frames using S375 fasteners.
- STEP 3: Slide correct number of P4200 jamb anchors into jamb anchor receivers. Jamb anchor count equals overall jamb dimension divided by 12" plus one. (ex: 72" jamb equals 6 anchors plus one...7 total)
- STEP 4: Attach head frame to jamb frames using S375 fasteners completing frame assembly.

CASSETTE FRAME GLAZING

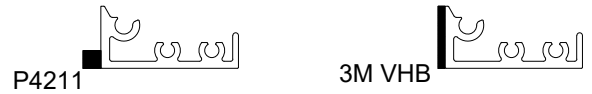
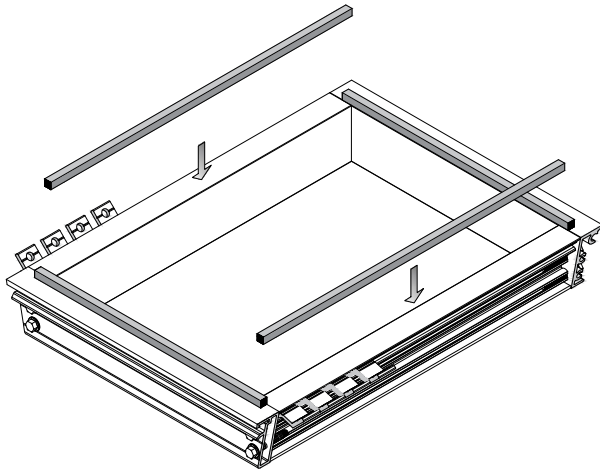

Apply tape at DLO head, sill and jambs.

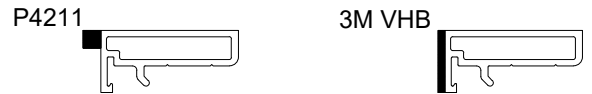

NOTE: If using 3M VHB glazing tape contact 3M for training certification and approvals.

CASSETTE GLAZING PREP and GLASS INSTALLATION

- STEP 1: Lay assembled cassette frame on glazing table and square frame, hold frame in square position.
- STEP 2: Using Isopropyl 70/30 mixture two towel wipe clean face of cassette frame that will glazed against.
- STEP 3: Install P4211 (1/4" x 1/4") Norton tape adhesive side to cassette face.
- STEP 4: Using Isopropyl 70/30 mixture two towel wipe clean surface of glass that will come in contact with silicone.
- STEP 5: Set glass to frame aligning edges of glass with frame.
 (note: glass size will vary, balance overage / under around frame)

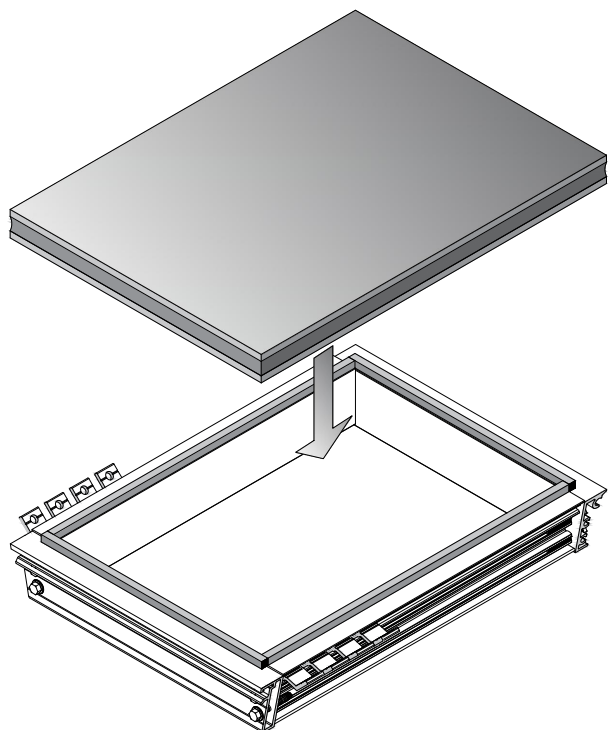
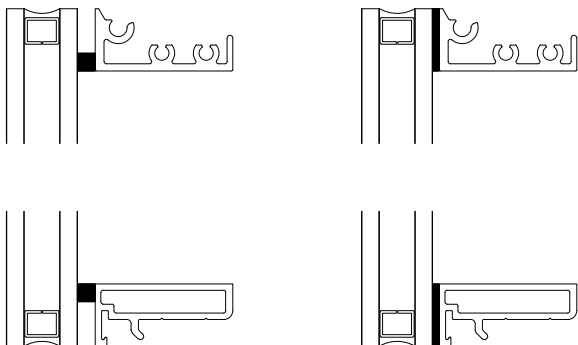

CASSETTE FRAME GLAZING - continued

CASSETTE SSG GLAZING

Note: Use high grade structural silicone for SSG glass attachment to cassette frames. Follow manufactures' recommendations for application...environmental conditions, curing time and handling.

- STEP 1: Fill void between cassette frame and glass with silicone.
- STEP 2: Tool silicone around perimeter of frame.
- STEP 3: Install setting block chair P4215 and setting block P1912S at quarter points. (Use setting block chair P4224 and P4603 setting block at quarter points when using VHB tape glazing)
- STEP 4: Move unit making sure not to disturb glass / cassette frame and let cure per manufactures' recommendations.

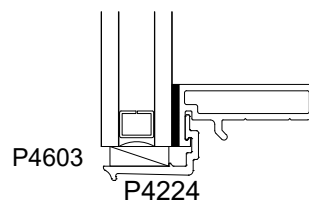
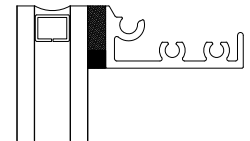

VHB TAPE

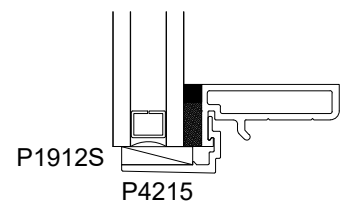

SILICONE

**CASSETTE FRAME SIZE CALCULATOR -
 "Glass-to-Edge" Head / Jamb**

Cassette frame overall dimension:

Vertical frame dimension: Back member DLO plus 3-3/8"

Horizontal frame dimension: Back member frame DLO plus 3-3/8"

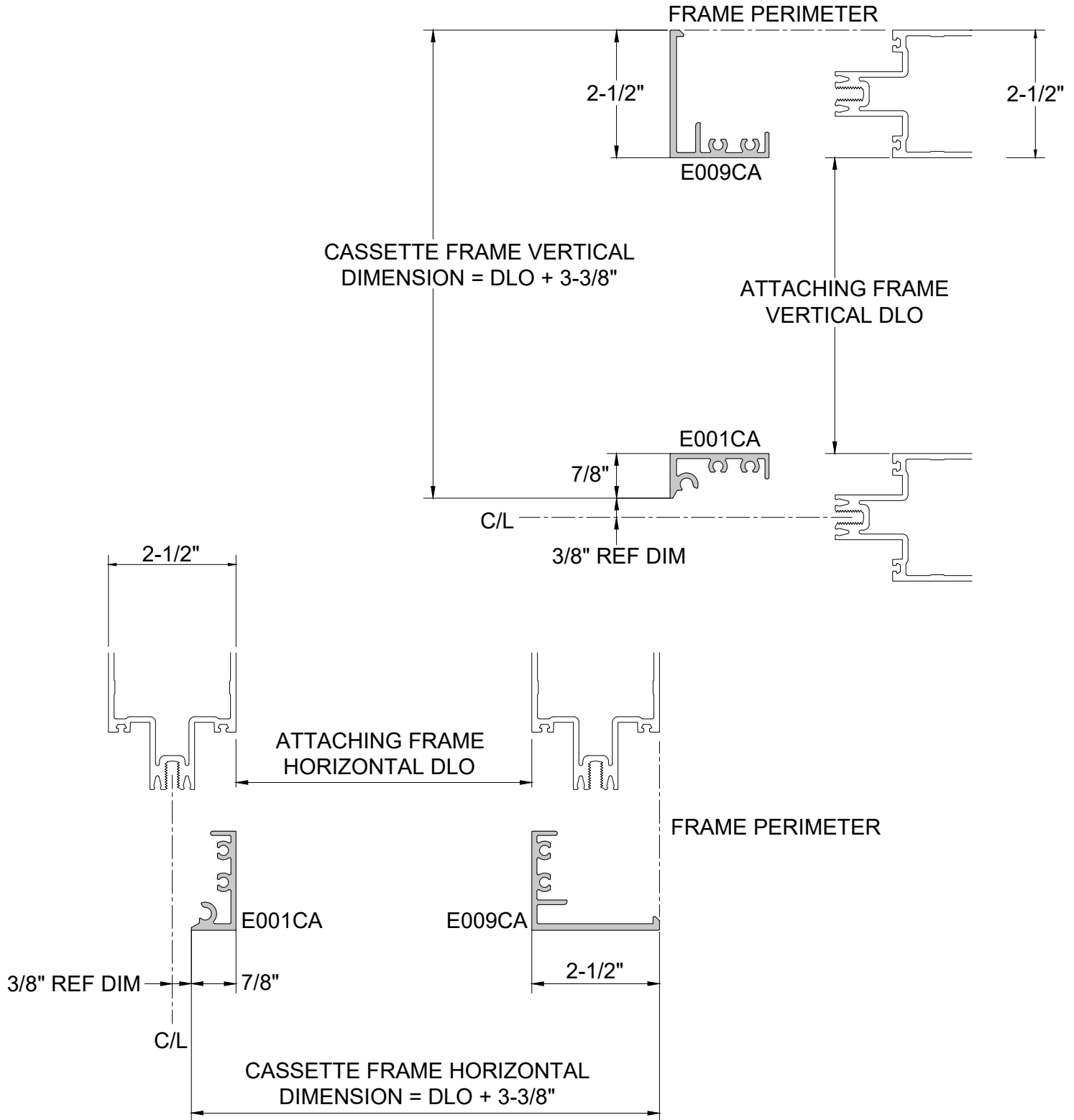

NOTE: Cassette frames sizes based on 400CW/T back members or 2-1/2" profile back members.

**CASSETTE FRAME CUT SIZE CALCULATOR -
 "Glass-to-Edge" Head / Jamb**

Cassette frame member Vertical / Horizontal cut size:

Vertical frame member cut size = DLO of attaching frame

Horizontal frame member cut size = DLO plus 3-3/8" of attaching frame

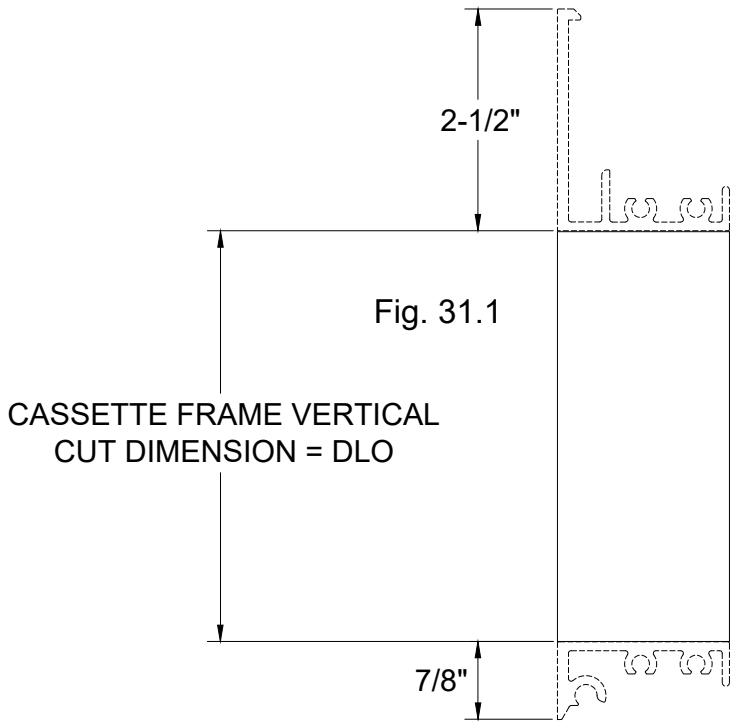

- STEP 1: Cut cassette vertical (jamb) framing members E001CA and E009CA to calculated lengths. Fig. 31.1.
- STEP 2: Cut cassette horizontal (head / sill) framing members E001CA and E009CA to calculated lengths.
- STEP 3: Cope one end of head and sill frame to match Fig. 31.2. This end will be intermediate jamb side.
- STEP 4: Cope other end of head and sill frame to match Fig. 31.3. This will be the "Glass-to-Edge" jamb side.

**VERTICAL FRAME SIZE CALCULATOR
 "Glass-to-Edge" at Head**

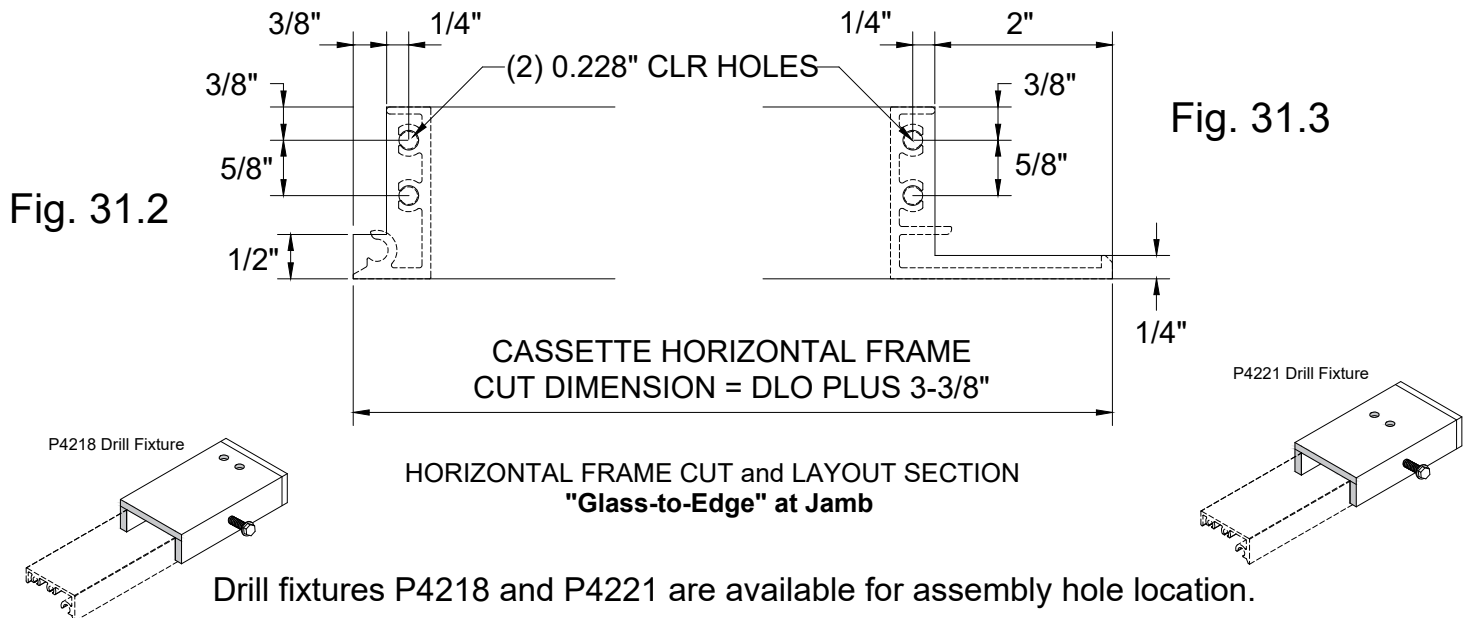

CASSETTE GLASS SIZE CALCULATOR -

"Glass-to-Edge" Head / Jamb

Cassette frame overall glass size:

Vertical glass size = Back member DLO plus 3-3/8"

Horizontal glass size = Back member DLO plus 3-3/8"

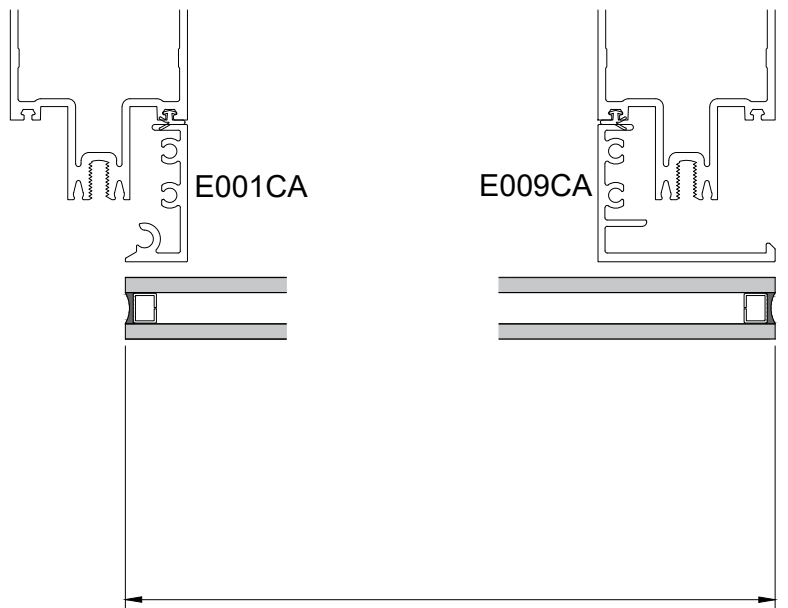
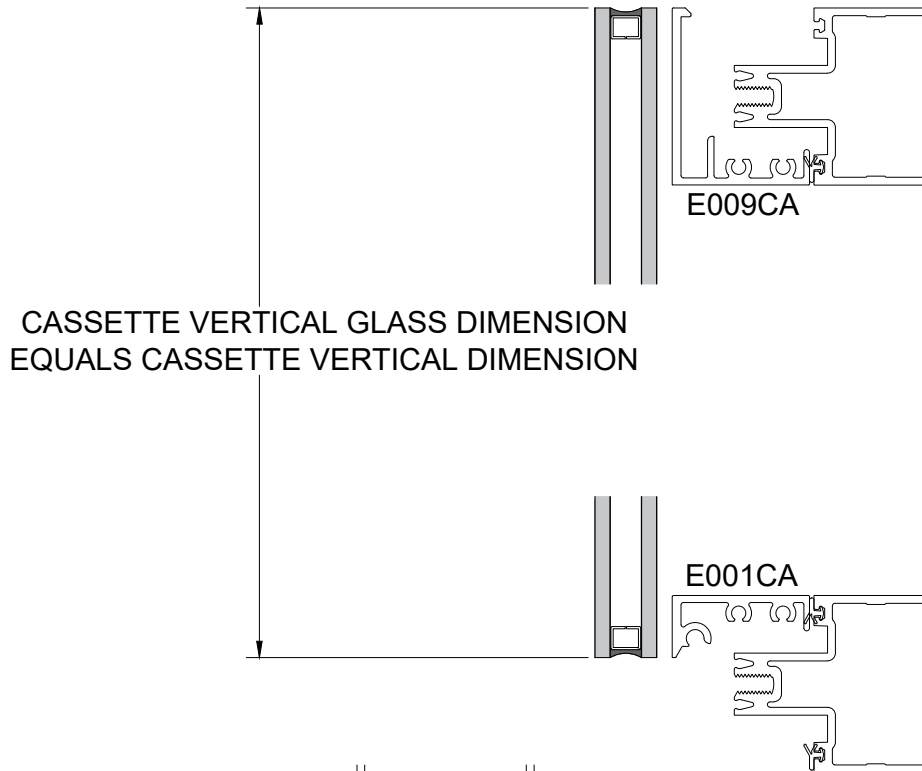

CASSETTE HORIZONTAL GLASS DIMENSION
EQUALS CASSETTE HORIZONTAL DIMENSION

CASSETTE FRAME ASSEMBLY - "Glass-to-Edge" Head / Jamb

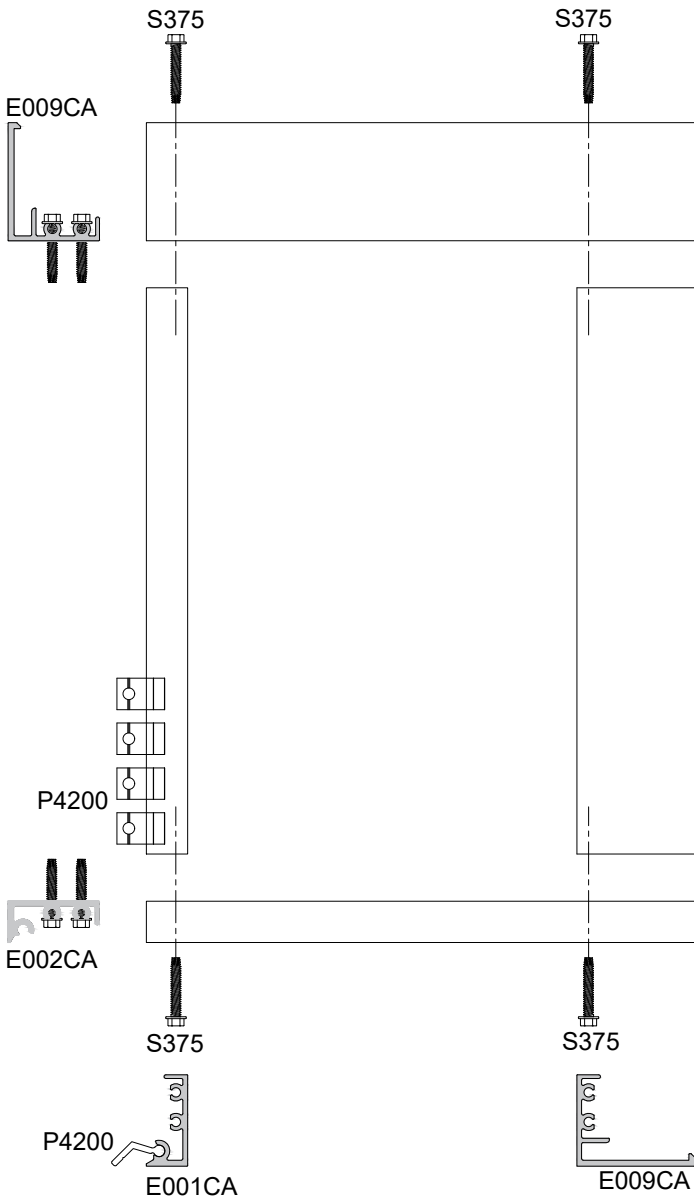

ALTERNATE JAMB ANCHOR INSTALLATION

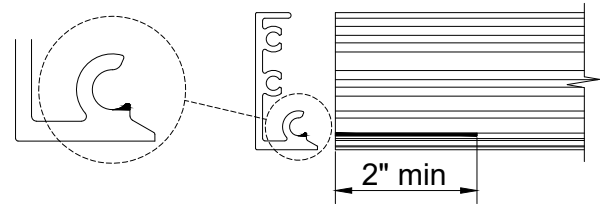

If the P4201 anchors are to be loaded in the jambs after the cassette frame had been assembled, the fabricator will need to remove the portion of the anchor receiver at the head of the jamb frames as shown above.

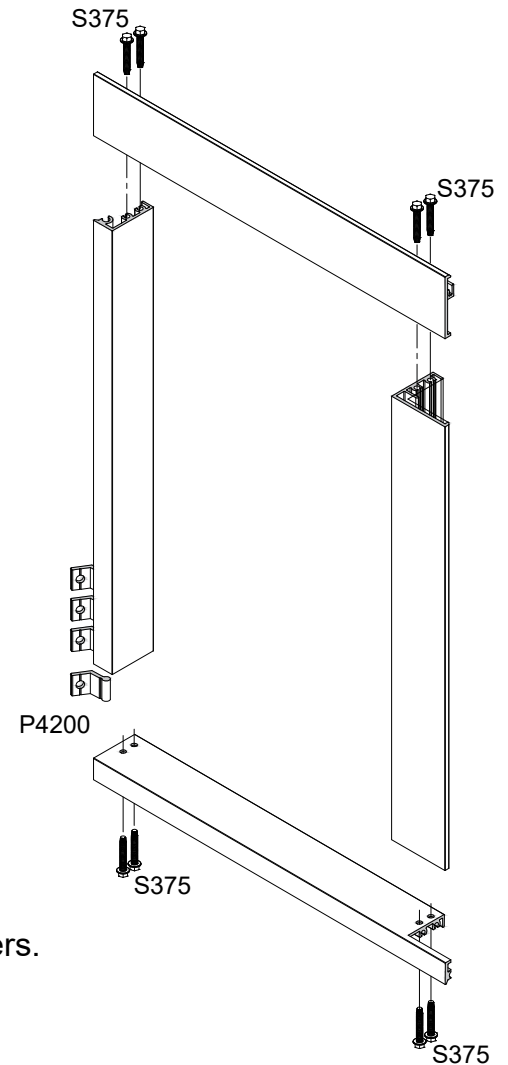

CASSETTE FRAME ASSEMBLY:

- STEP 1: Layout head, sill and jambs on table for assembly.
- STEP 2: Attach sill frame to jamb frames using S375 fasteners.
- STEP 3: Slide correct number of P4200 jamb anchors into jamb anchor receivers. Jamb anchor count equals overall jamb dimension divided by 12" plus one.
(ex: 72" jamb equals 6 anchors plus one...7 total)
- STEP 4: Attach head frame to jamb frames using S375 fasteners completing frame assembly.

CASSETTE FRAME GLAZING - "Glass-to-Edge" Head / Jamb

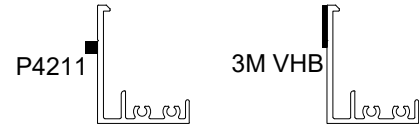
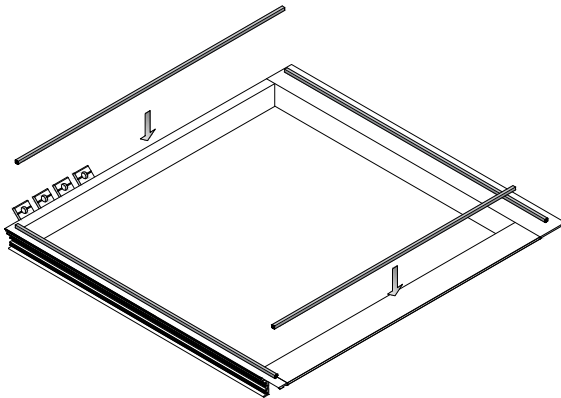

Apply tape at "V" groove and jamb. Follow DLO at sill and opposite jamb.

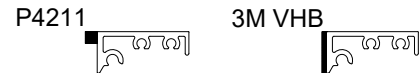

NOTE: If using 3M VHB glazing tape contact 3M for training certification and approvals.

CASSETTE GLAZING PREP and GLASS INSTALLATION

- STEP 1: Lay assembled cassette frame on glazing table and square frame, hold frame in square position.
- STEP 2: Using Isopropyl 70/30 mixture two towel wipe, clean face of cassette frame that will glazed against.
- STEP 3: Install P4211 (1/4" x 1/4") Norton tape adhesive side to cassette face.
- STEP 4: Using Isopropyl 70/30 mixture two towel wipe, clean surface of glass that will come in contact with silicone.
- STEP 5: Set glass to frame aligning edges of glass with frame.
(note: glass size will vary, balance overage / under around frame)

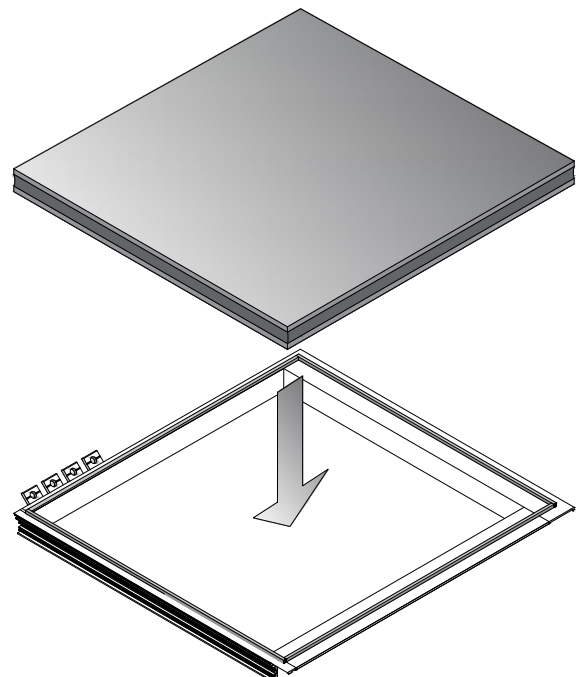
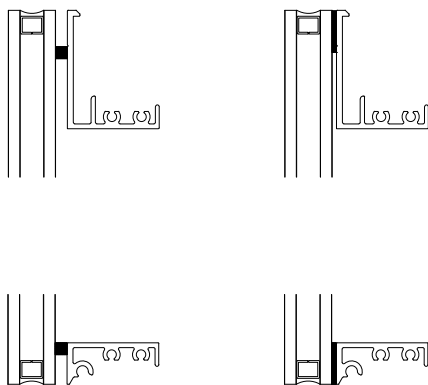

CASSETTE FRAME GLAZING - "Glass-to-Edge" Head / Jamb - cont.

CASSETTE SSG GLAZING

NOTE: Glazing contractor is responsible for selection and proper installation of silicone for glass to cassette attachment / glazing. Follow manufacturer's recommendations for application...environmental conditions, curing time and handling.
 (Dow 995 was used by Tubelite for performance mock up)

- STEP 1: Fill void between cassette frame and glass with silicone.
- STEP 2: Tool silicone around perimeter of frame.
- STEP 3: Prior to installing setting block chair P4217 install correct number of center anchors P4200 as shown in Fig. 35.1.
- STEP 4: Install setting block chair P4217 and setting block P1912S at quarter points. (Use setting block chair P4225 and P4603 setting block at quarter points when using VHB tape glazing)
- STEP 5: Move unit making sure not to disturb glass / cassette frame and let cure per manufactures' recommendations.

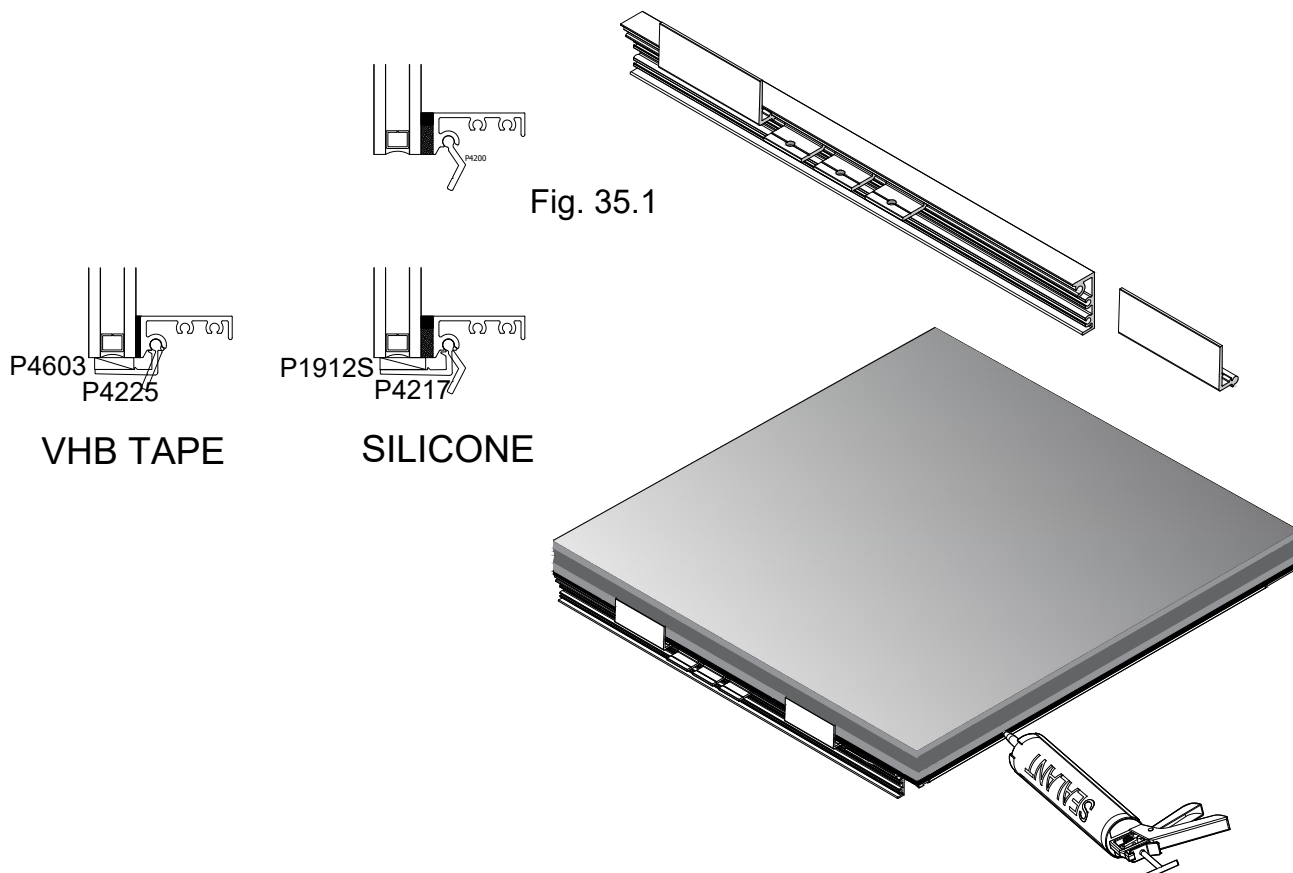

CASSETTE FRAME INSTALLATION - "Glass-to-Edge" Head / Jamb

NOTE: Cassette framing consisting of both Head and Jamb "Glass-to-Edge" frames must be installed prior to adjacent frames and frame directly below.

- STEP 1: Position the cassette frame at a slight angle to the head framing as shown in Fig.36.1 and off the jamb anchor as shown in Fig. 36.3 with the frame shifted away from the perimeter.
- STEP 2: Roll the sill of the cassette frame towards the sill back member and slide up engaging the head anchor as shown in Fig. 36.2.
- STEP 3: Slide the cassette frame horizontally to engage the jamb anchor as shown in Fig. 36.4.
- STEP 4: Attach sill anchors P4200 at 12" o/c and no more than 2" from ends.

NOTE: Cassette unit below must use anchor P4200 at sill versus P4202 for installation clearance. Refer to PERIMETER SHEETS - DTL. 2B.

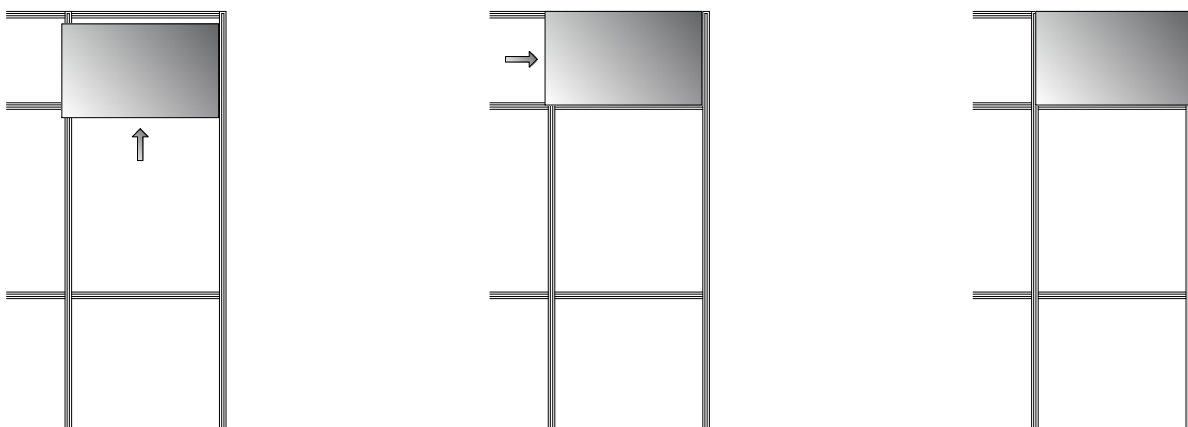
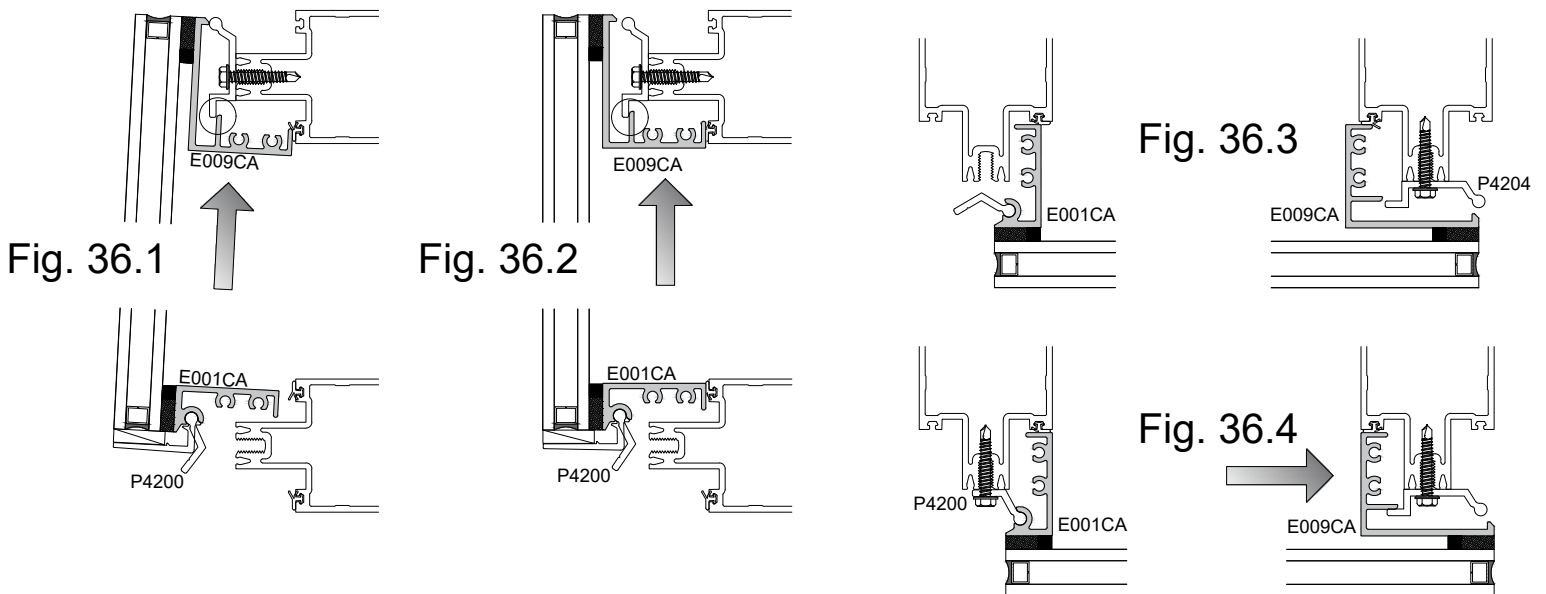

Partial elevation showing cassette frame movements for installation

CASSETTE FRAME SIZE CALCULATOR - "Glass-to-Edge" Head

Cassette frame overall dimension:

Vertical frame dimension: Back member DLO plus 3-3/8"

Horizontal frame dimension: Back member frame DLO plus 1-3/4"

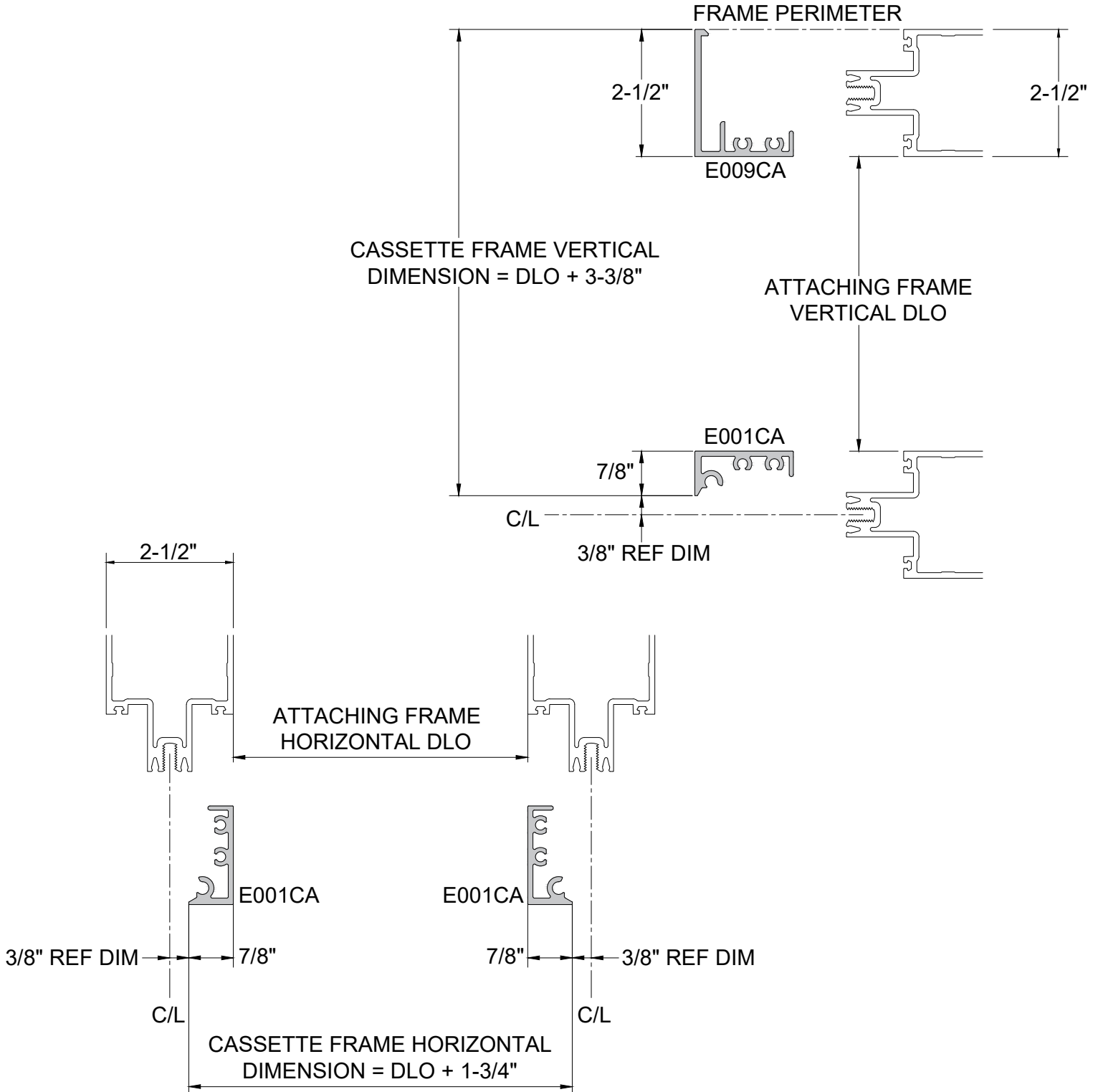

NOTE: Cassette frames sizes based on 400CW/T back members or 2-1/2" profile back members.

CASSETTE FRAME CUT SIZE CALCULATOR

"Glass-to-Edge" Head

Cassette frame member Vertical / Horizontal cut size:

Vertical frame member cut size = DLO of attaching frame

Horizontal frame member cut size = DLO plus 1-3/4" of attaching frame

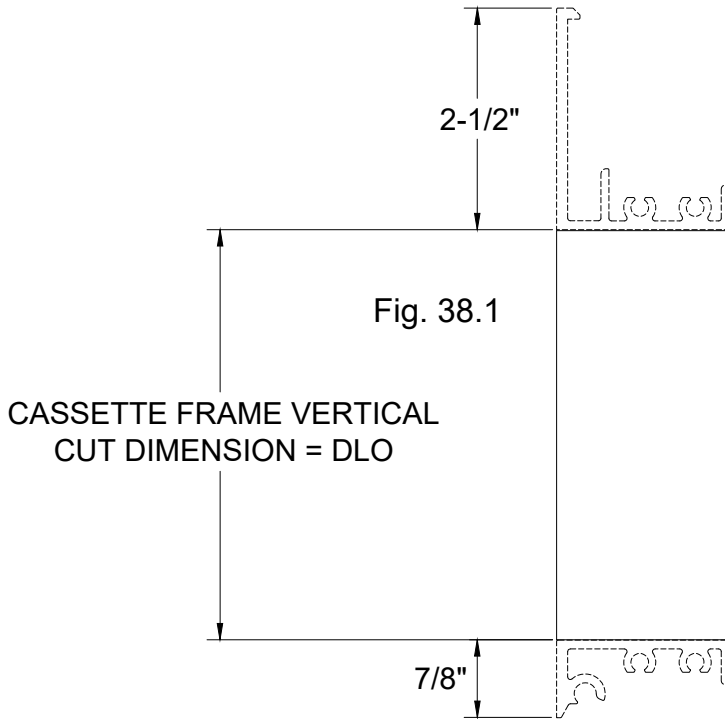

STEP 1: Cut cassette vertical (jamb) framing members E001CA to calculated lengths. Fig. 38.1.

STEP 2: Cut cassette head horizontal E009CA member to calculated length then miter both ends 11 degrees from front face of frame shown at Fig. 38.2.

STEP 3: Cut cassette sill horizontal E001CA member to calculated length then miter both ends 11 degrees from front face of frame shown at Fig. 38.2.

VERTICAL FRAME SIZE CALCULATOR
"Glass-to-Edge" at Head

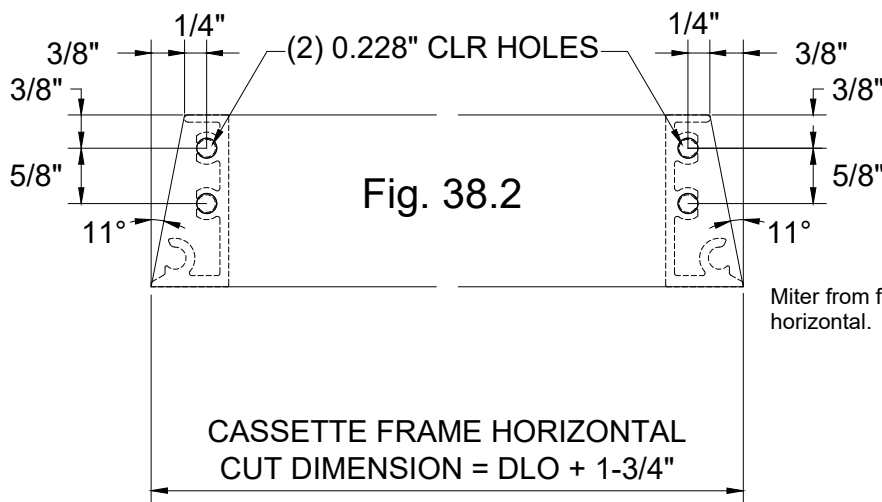

HORIZONTAL FRAME CUT and LAYOUT SECTION
 Standard Framing

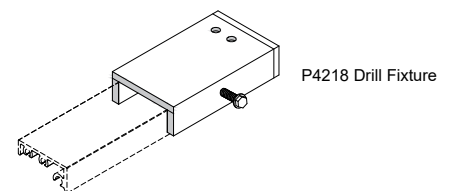

Assemble hole location as outlined below or drill fixture P4218 is available to assist with assemble hole location.

CASSETTE GLASS SIZE CALCULATOR - "Glass-to-Edge" Head

Cassette frame overall glass size:

Vertical glass size = Back member DLO plus 3-3/8"

Horizontal glass size = Back member DLO plus 1-3/4"

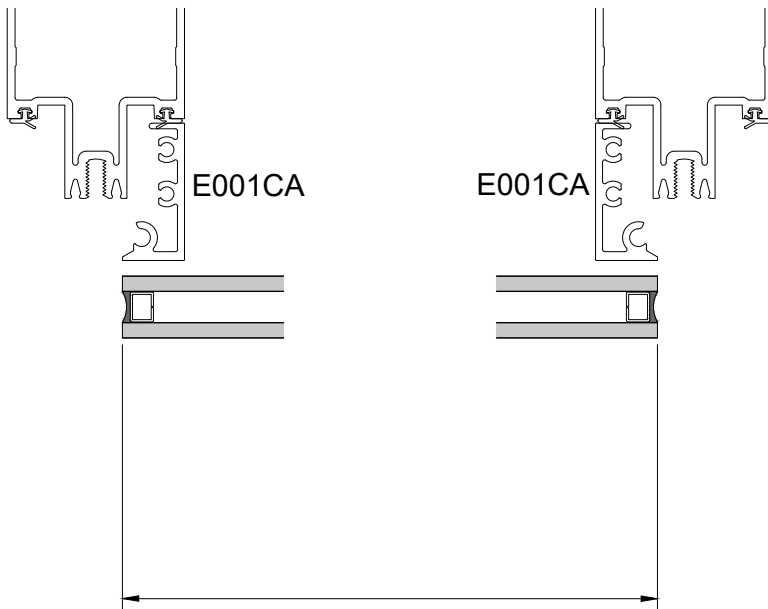
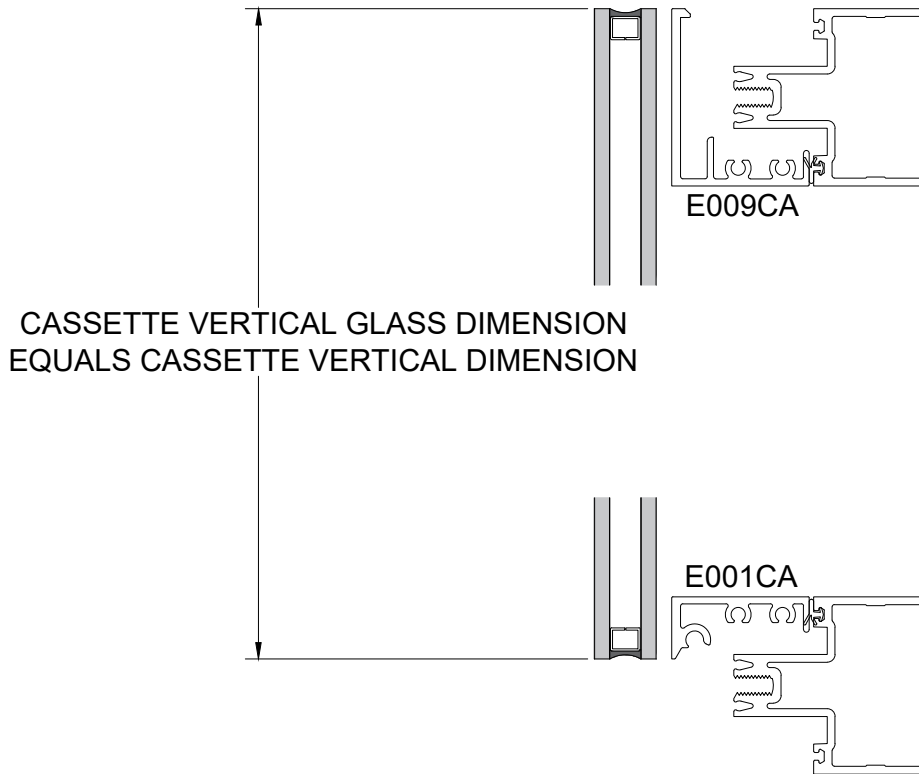

CASSETTE HORIZONTAL GLASS DIMENSION
EQUALS CASSETTE HORIZONTAL DIMENSION

CASSETTE FRAME ASSEMBLY - "Glass-to-Edge" Head

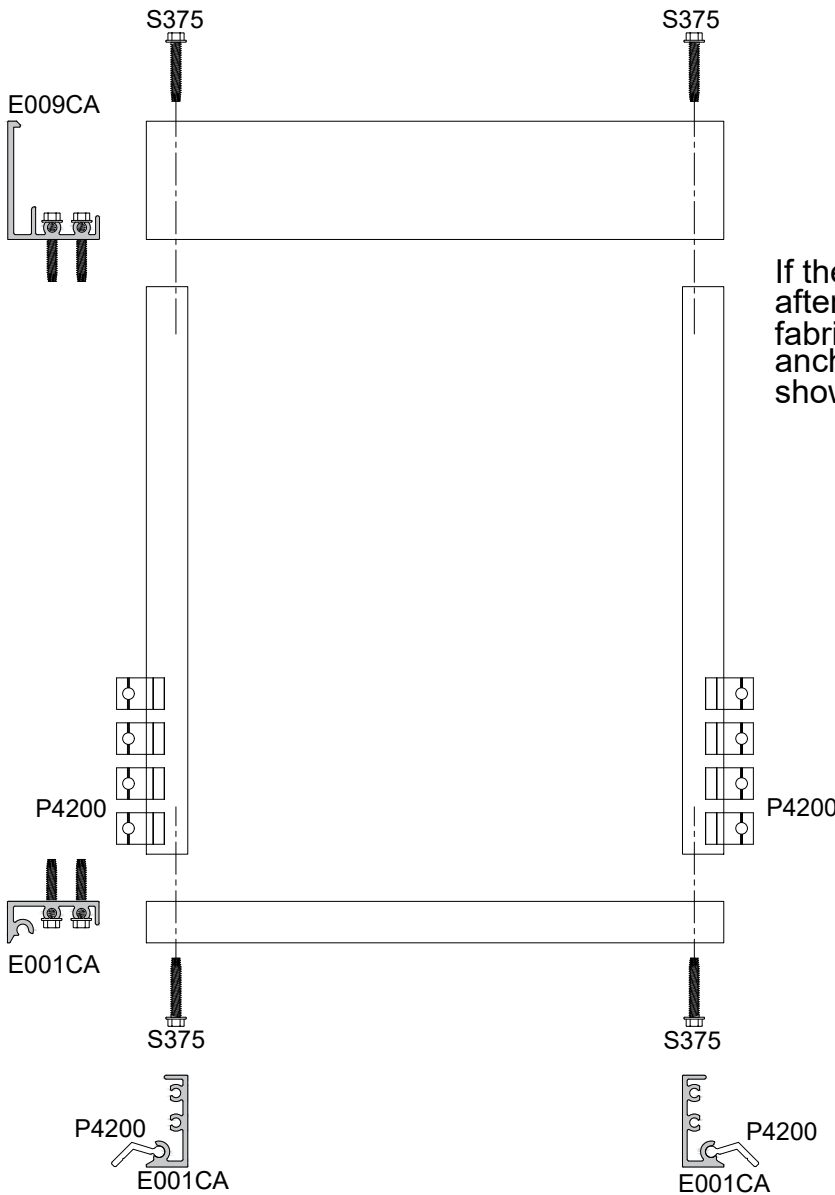

ALTERNATE JAMB ANCHOR INSTALLATION

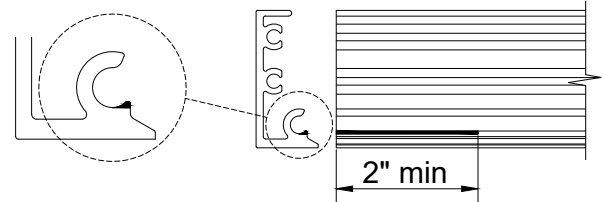

If the P4201 anchors are to be loaded in the jambs after the cassette frame had been assembled, the fabricator will need to remove the portion of the anchor receiver at the head of the jamb frames as shown above.

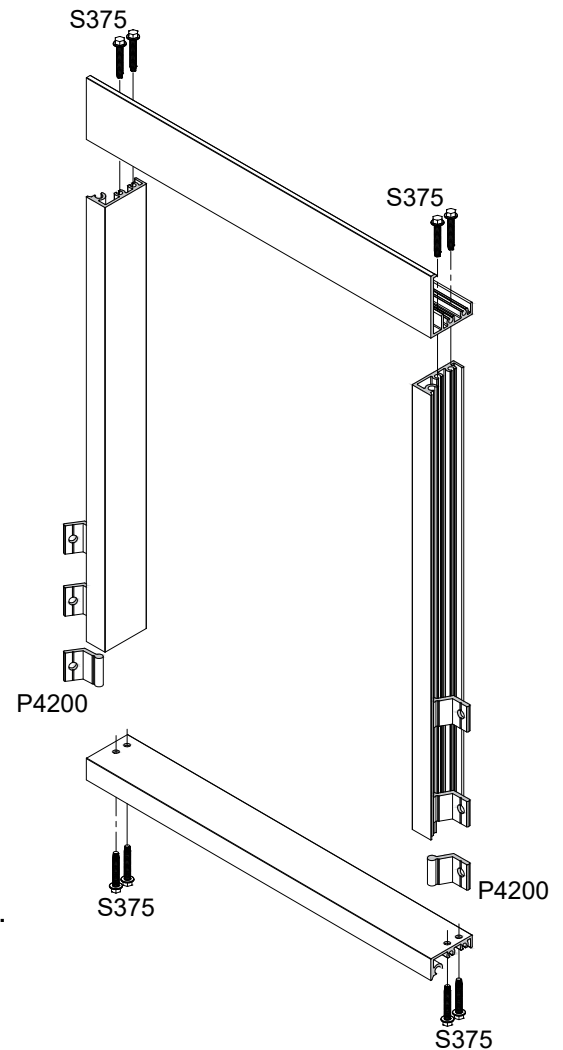

CASSETTE FRAME ASSEMBLY:

- STEP 1: Layout head, sill and jambs on table for assembly.
- STEP 2: Attach sill frame to jamb frames using S375 fasteners.
- STEP 3: Slide correct number of P4201 jamb anchors into jamb anchor receivers. Jamb anchor count equals overall jamb dimension divided by 12" plus one. (ex: 72" jamb equals 6 anchors plus one...7 total)
- STEP 4: Attach head frame to jamb frames using S375 fasteners completing frame assembly.

CASSETTE FRAME GLAZING - "Glass-to-Edge" Head

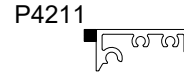
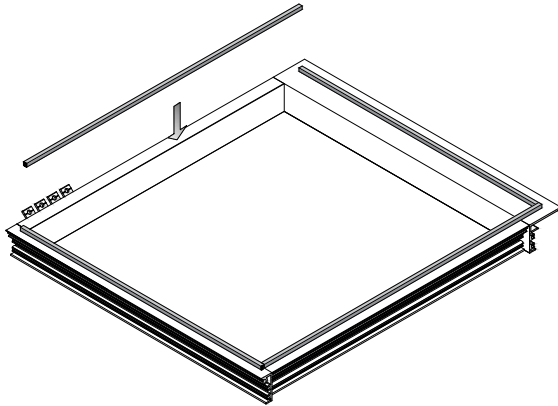

NOTE: If using 3M VHB glazing tape contact 3M for training certification and approvals.

CASSETTE GLAZING PREP and GLASS INSTALLATION

- STEP 1: Lay assembled cassette frame on glazing table and square frame, hold frame in square position.
- STEP 2: Using Isopropyl 70/30 mixture two towel wipe clean face of cassette frame that will glazed against.
- STEP 3: Install P4211 (1/4" x 1/4") Norton tape adhesive side to cassette face.
- STEP 4: Using Isopropyl 70/30 mixture two towel wipe clean surface of glass that will come in contact with silicone.
- STEP 5: Set glass to frame aligning edges of glass with frame.
(note: glass size will vary, balance overage / under around frame)

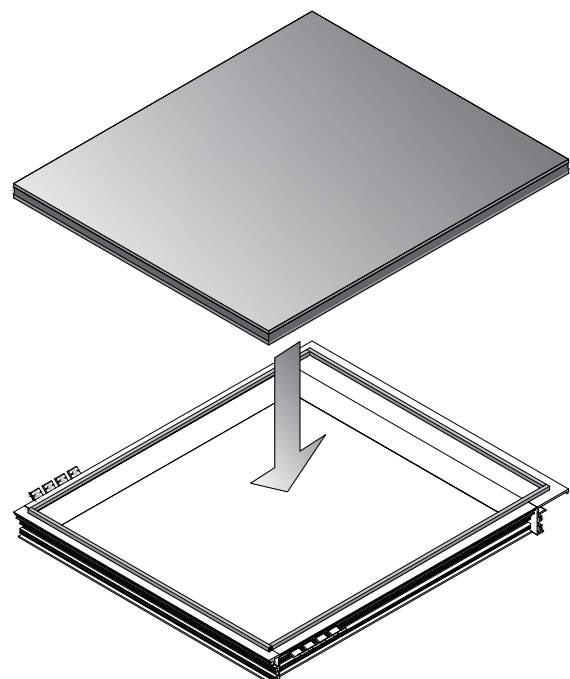
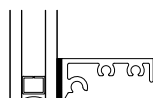
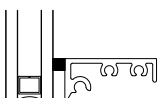
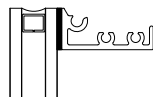
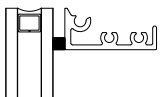

CASSETTE FRAME GLAZING - "Glass-to-Edge" Head - cont.

CASSETTE SSG GLAZING

Note: Use high grade structural silicone for SSG glass attachment to cassette frames. Follow manufactures' recommendations for application...environmental conditions, curing time and handling.

- STEP 1: Fill void between cassette frame and glass with silicone.
- STEP 2: Tool silicone around perimeter of frame.
- STEP 3: Prior to installing setting block chair P4217 install correct number of center anchors P4200 as shown in Fig. 42.1.
- STEP 4: Install setting block chair P4217 and setting block P1912S at quarter points.
- STEP 5: Move unit making sure not to disturb glass / cassette frame and let cure per manufactures' recommendations.

Fig. 42.1

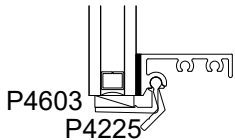
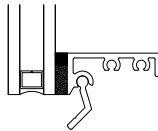
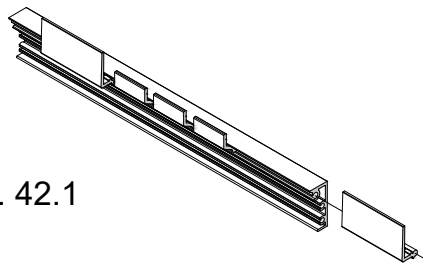

VHB TAPE

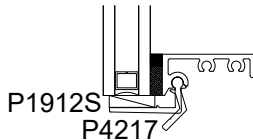

SILICONE

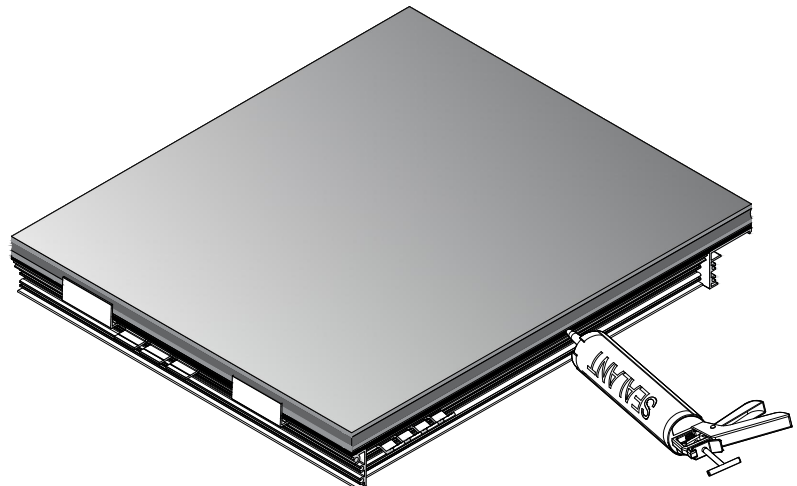

CASSETTE FRAME INSTALLATION - "Glass-to-Edge" Head

STEP 1: Position the cassette frame at a slight angle to the head frame back member as shown in Fig. 43.1

STEP 2: Roll the sill of the cassette frame towards the sill of the back member and slide up engaging the head anchor P4204 as shown in Fig. 43.2.

STEP 3: Attach sill anchors P4200, Fig. 43.2 at 12" o/c and no more than 2" from ends.

STEP 4: Attach jamb / sill anchors P4201, Fig 43.3 at 12" o/c and no more than 2" from ends.

NOTE: Cassette unit below must use anchor P4200 at sill versus P4202 for installation clearance. Refer to PERIMETER SHEETS - DTL. 2B.

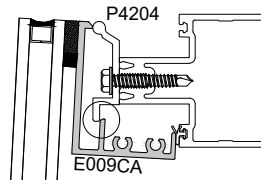

Fig. 43.1

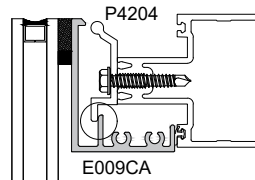

Fig. 43.2

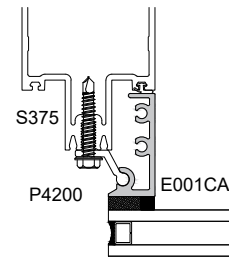
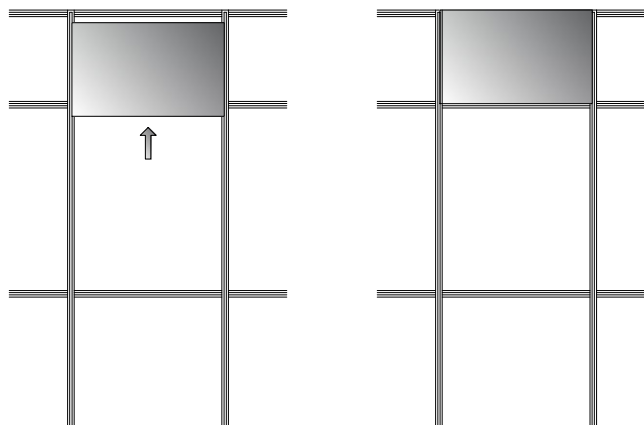
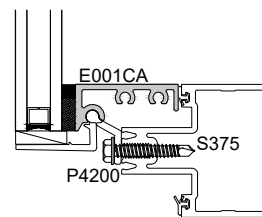
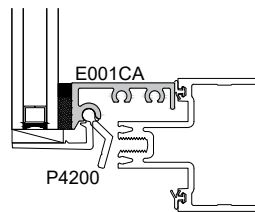
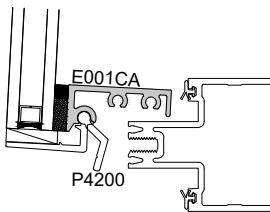

Fig. 43.3



Partial elevation showing cassette frame movements for installation

CASSETTE FRAME SIZE CALCULATOR - "Glass-to-Edge" Sill

Cassette frame overall dimension:

Vertical frame dimension: Back member DLO plus 3-7/16"

Horizontal frame dimension: Back member frame DLO plus 1-3/4"

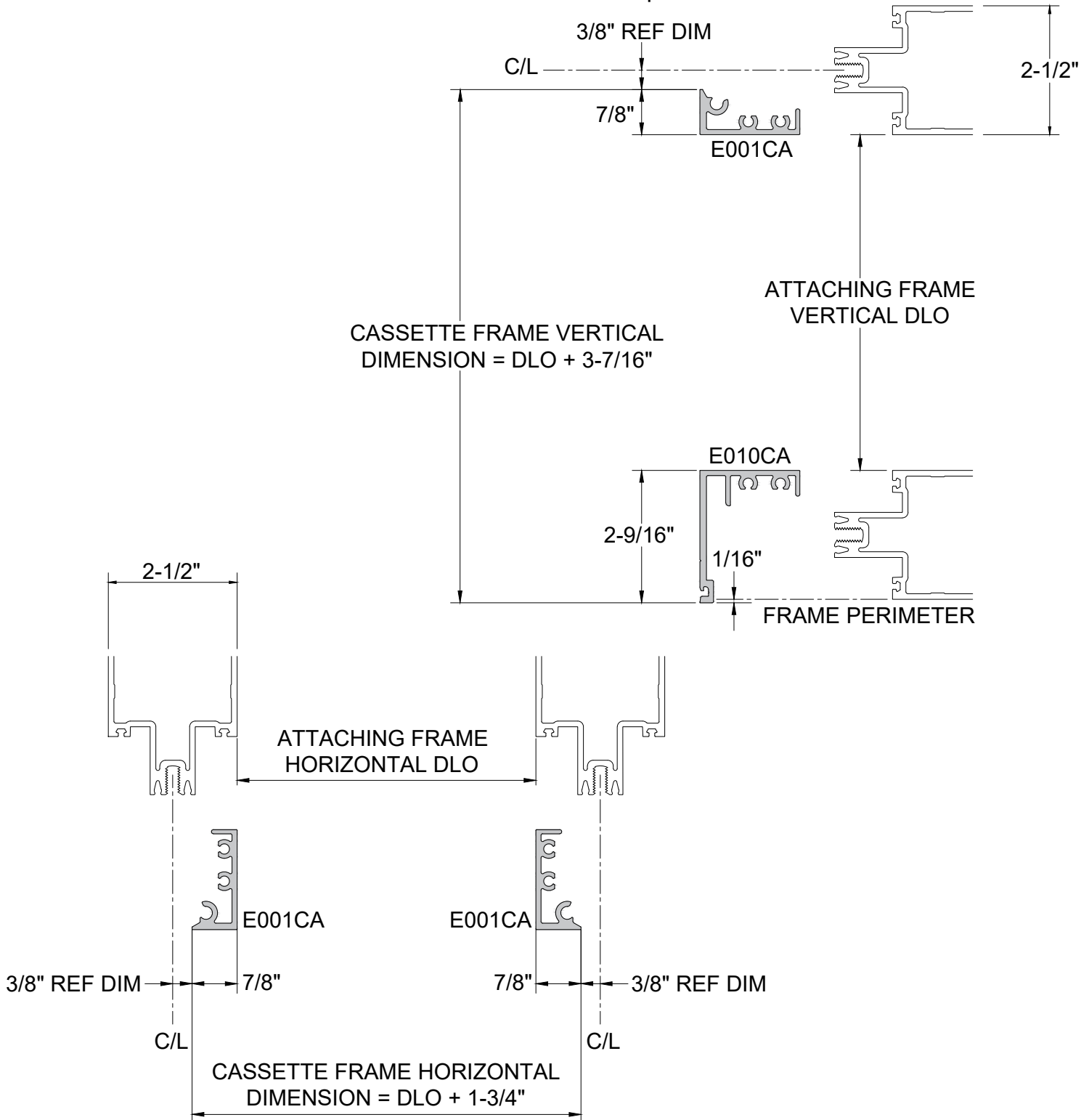

NOTE: Cassette frames sizes based on 400CW/T back members or 2-1/2" profile back members.

**CASSETTE FRAME CUT SIZE CALCULATOR -
 "Glass-to-Edge" Sill**

Cassette frame member Vertical / Horizontal cut size:

Vertical frame member cut size = DLO of attaching frame

Horizontal frame member cut size = DLO plus 1-3/4" of attaching frame

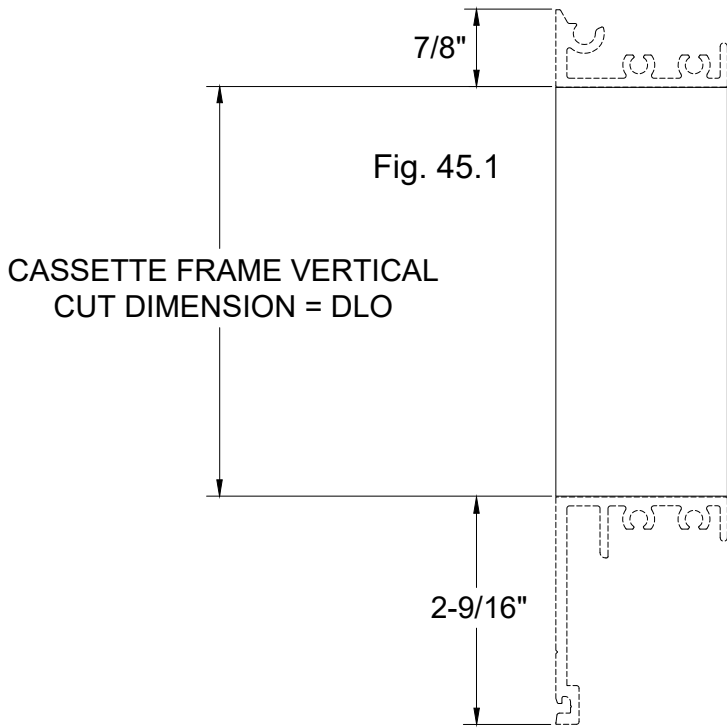

**VERTICAL FRAME SIZE CALCULATOR
 "Glass-to-Edge" at Sill**

STEP 1: Cut cassette vertical (jamb) framing members E001CA to calculated lengths. Fig. 45.1.

STEP 2: Cut cassette head horizontal E001CA member to calculated length then miter both ends 11 degrees from front face of frame shown at Fig. 45.2.

STEP 3: Cut cassette sill horizontal E010CA member to calculated length then miter both ends 11 degrees from front face of frame shown at Fig. 45.2.

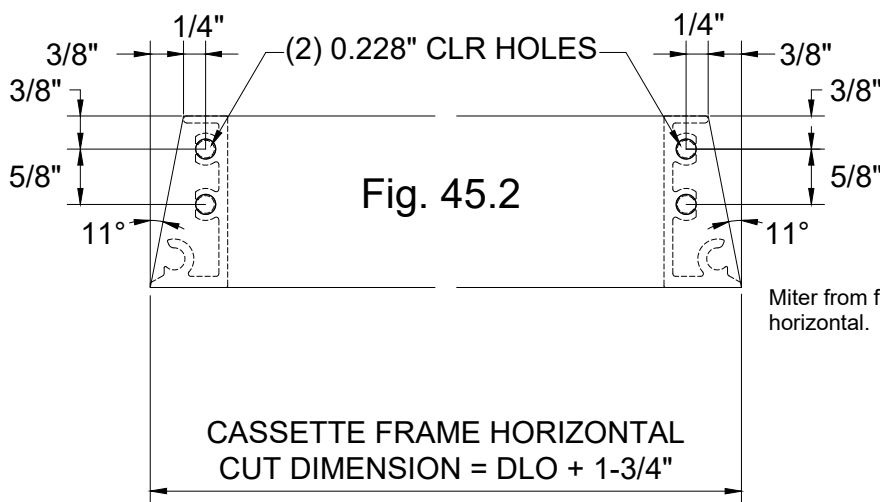

**HORIZONTAL FRAME CUT and LAYOUT SECTION
 Standard Framing**

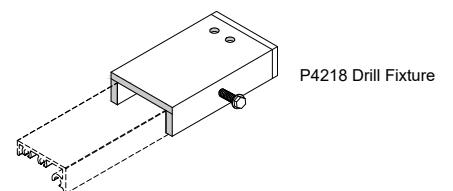

Assemble hole location as outlined below or drill fixture P4218 is available to assist with assemble hole location.

CASSETTE GLASS SIZE CALCULATOR - "Glass-to-Edge" Sill

Cassette frame overall glass size:

Vertical glass size = Back member DLO plus 3"

Horizontal glass size = Back member DLO plus 1-3/4"

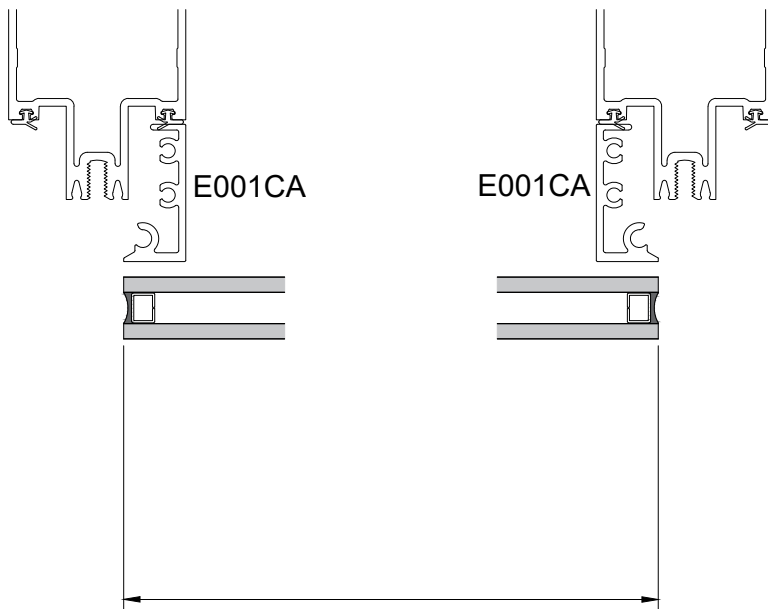
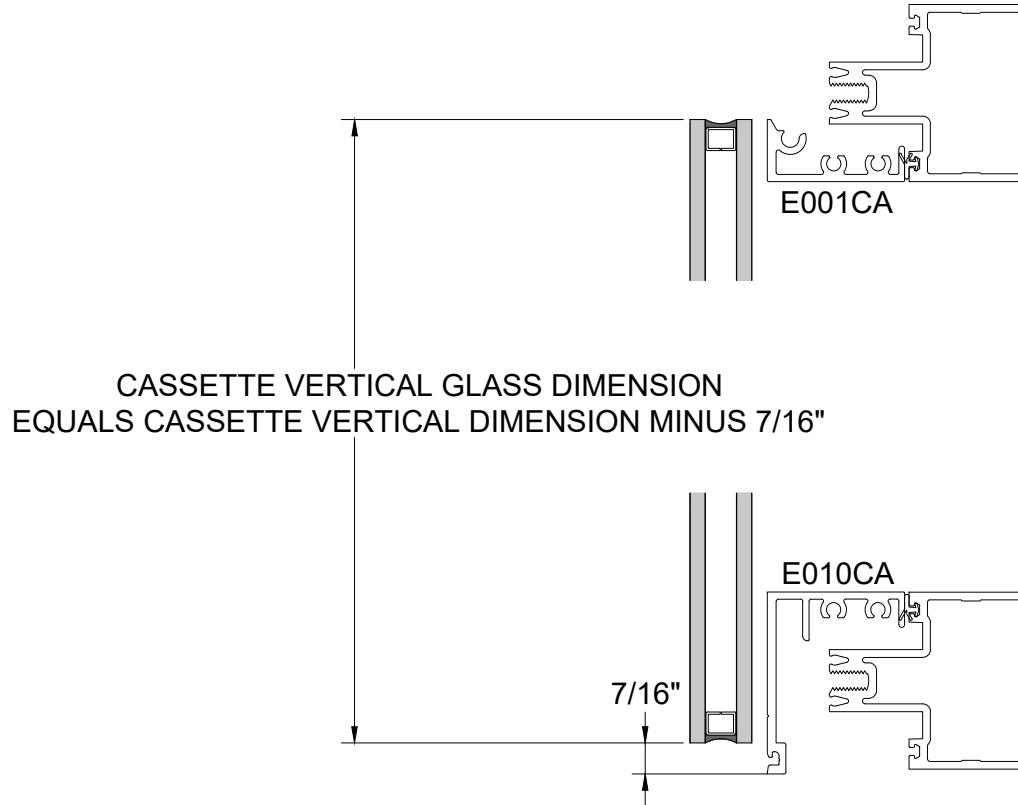

CASSETTE HORIZONTAL GLASS DIMENSION
EQUALS CASSETTE HORIZONTAL DIMENSION

CASSETTE FRAME ASSEMBLY - "Glass-to-Edge" Sill

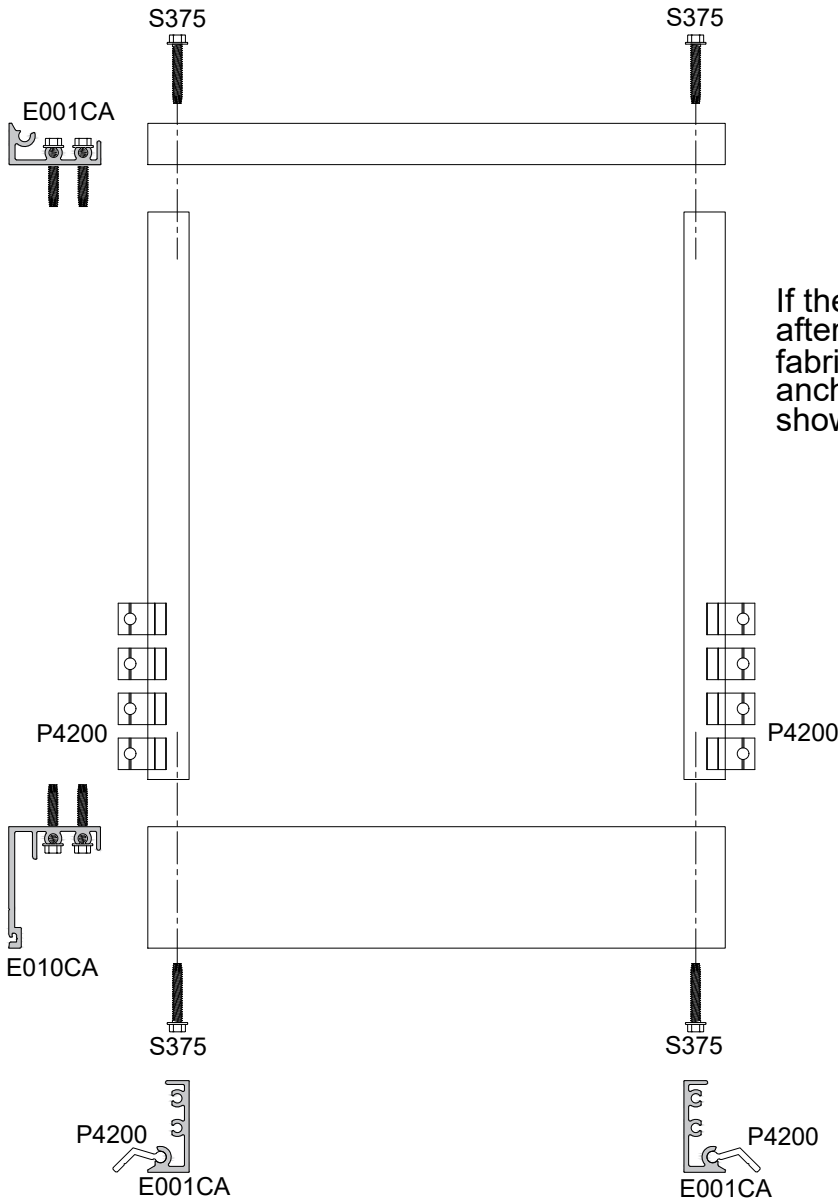

ALTERNATE JAMB ANCHOR INSTALLATION

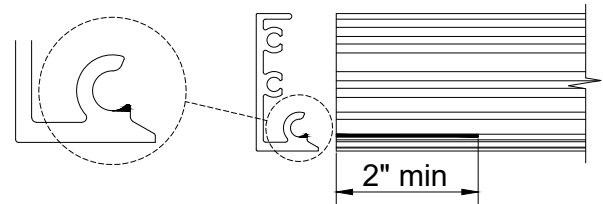

If the P4200 anchors are to be loaded in the jambs after the cassette frame had been assembled, the fabricator will need to remove the portion of the anchor receiver at the head of the jamb frames as shown above.

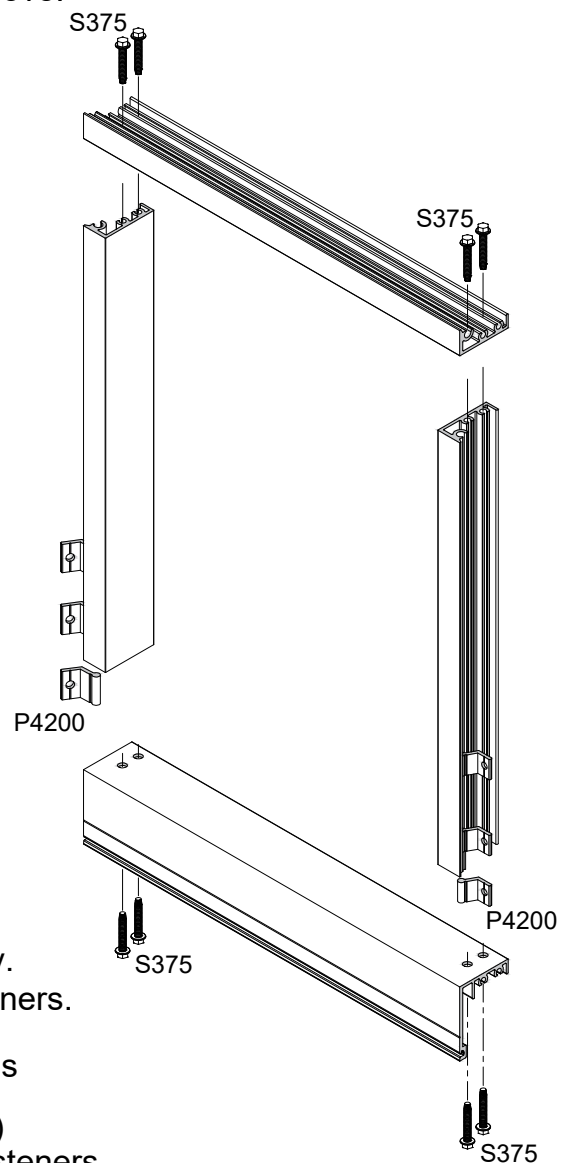

CASSETTE FRAME ASSEMBLY:

- STEP 1: Layout head, sill and jambs on table for assembly.
- STEP 2: Attach sill frame to jamb frames using S375 fasteners.
- STEP 3: Slide correct number of P4200 jamb anchors into jamb anchor receivers. Jamb anchor count equals overall jamb dimension divided by 12" plus one. (ex: 72" jamb equals 6 anchors plus one...7 total)
- STEP 4: Attach head frame to jamb frames using S375 fasteners completing frame assembly.

CASSETTE FRAME GLAZING - "Glass-to-Edge" Sill

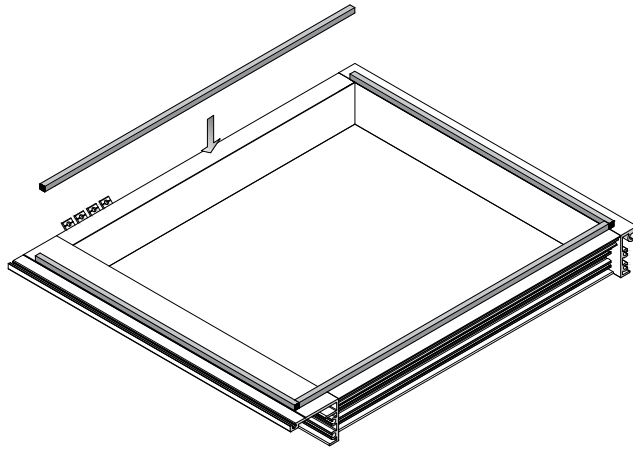

Apply tape at "V" groove at sill. Follow DLO at head and jambs.

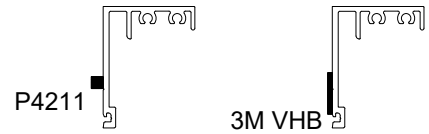

NOTE: If using 3M VHB glazing tape contact 3M for training certification and approvals.

CASSETTE GLAZING PREP and GLASS INSTALLATION

- STEP 1: Lay assembled cassette frame on glazing table and square frame, hold frame in square position.
- STEP 2: Using Isopropyl 70/30 mixture two towel wipe, clean face of cassette frame that will glazed against.
- STEP 3: Install P4211 (1/4" x 1/4") Norton tape adhesive side to cassette face.
- STEP 4: Using Isopropyl 70/30 mixture two towel wipe, clean surface of glass that will come in contact with silicone.
- STEP 5: Set glass to frame aligning edges of glass with frame.
(note: glass size will vary, balance overage / under around frame)

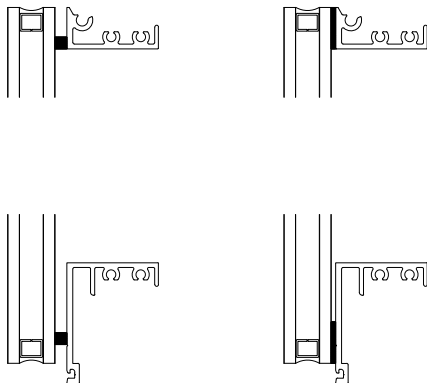

CASSETTE FRAME GLAZING - "Glass-to-Edge" Sill cont.

CASSETTE SSG GLAZING

NOTE: Glazing contractor is responsible for selection and proper installation of silicone for glass to cassette attachment / glazing. Follow manufacturer's recommendations for application...environmental conditions, curing time and handling.
(Dow 995 was used by Tubelite for performance mock up)

- STEP 1: Fill void between cassette frame and glass with silicone.
- STEP 2: Tool silicone around perimeter of frame.
- STEP 3: Install setting block chair P4623 and setting block P1912S at quarter points. (Use setting block chair P4226 and setting block P4603 at quarter points when using VHB tape glazing.)
- STEP 4: Move unit making sure not to disturb glass / cassette frame and let cure per manufactures' recommendations.

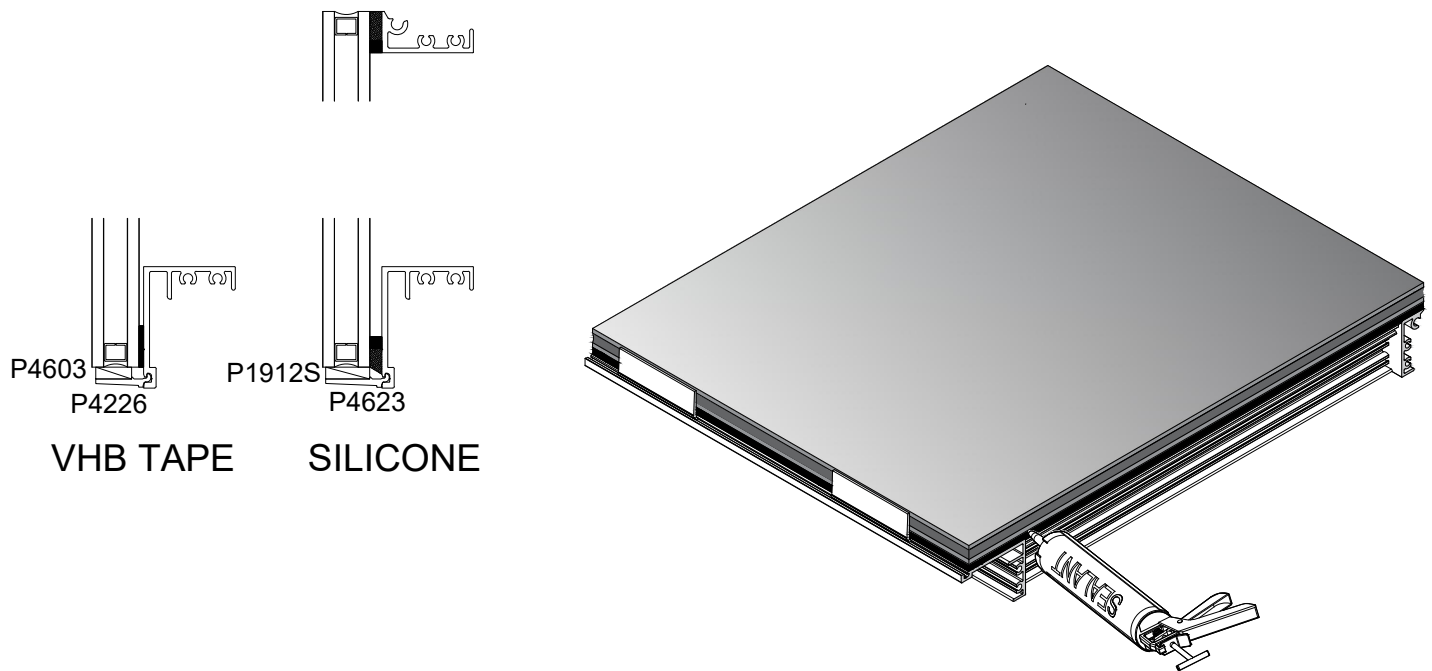

CASSETTE FRAME "Glass-to-Edge" Sill Installation

- STEP 1: Install dead load blocking P4212 between sill anchor clips P4222.
- STEP 2: Set sill of assembled cassette frame on anchor clips P4222 and roll head of frame toward back member support framing as shown at Fig. 50.1.
- STEP 3: Attach head anchor P4202 to back member support framing intermediate as shown at Fig. 50.2.
- STEP 4: Continue to attach head anchors and attach jamb anchors P4200 as shown at Fig. 50.3.

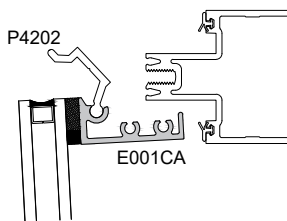

Fig. 50.1

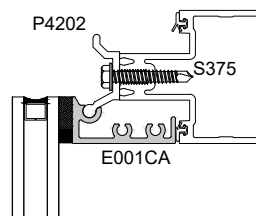

Fig. 50.2

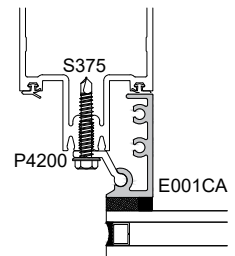
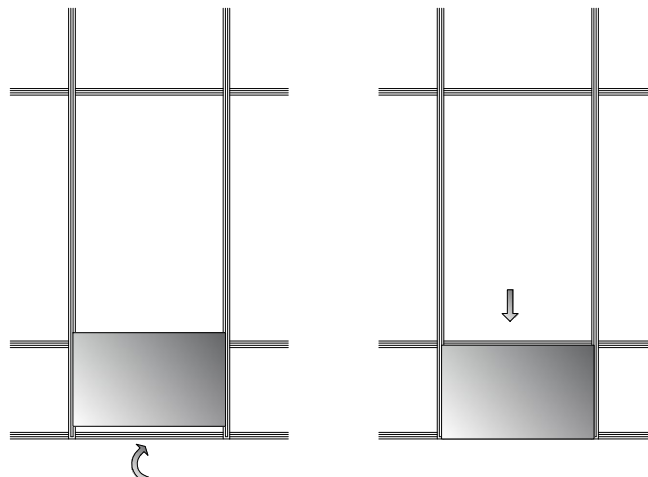
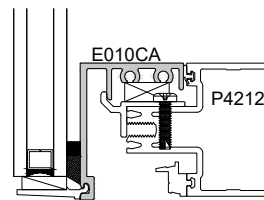
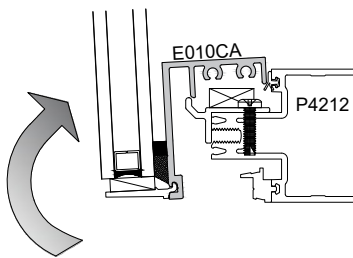

Fig. 50.3



Partial elevation showing cassette frame movements for installation

CASSETTE FRAME SIZE CALCULATOR -

"Glass-to-Edge" Sill / Jamb

Cassette frame overall dimension:

Vertical frame dimension: Back member DLO plus 3-7/16"

Horizontal frame dimension: Back member frame DLO plus 2-3/8"

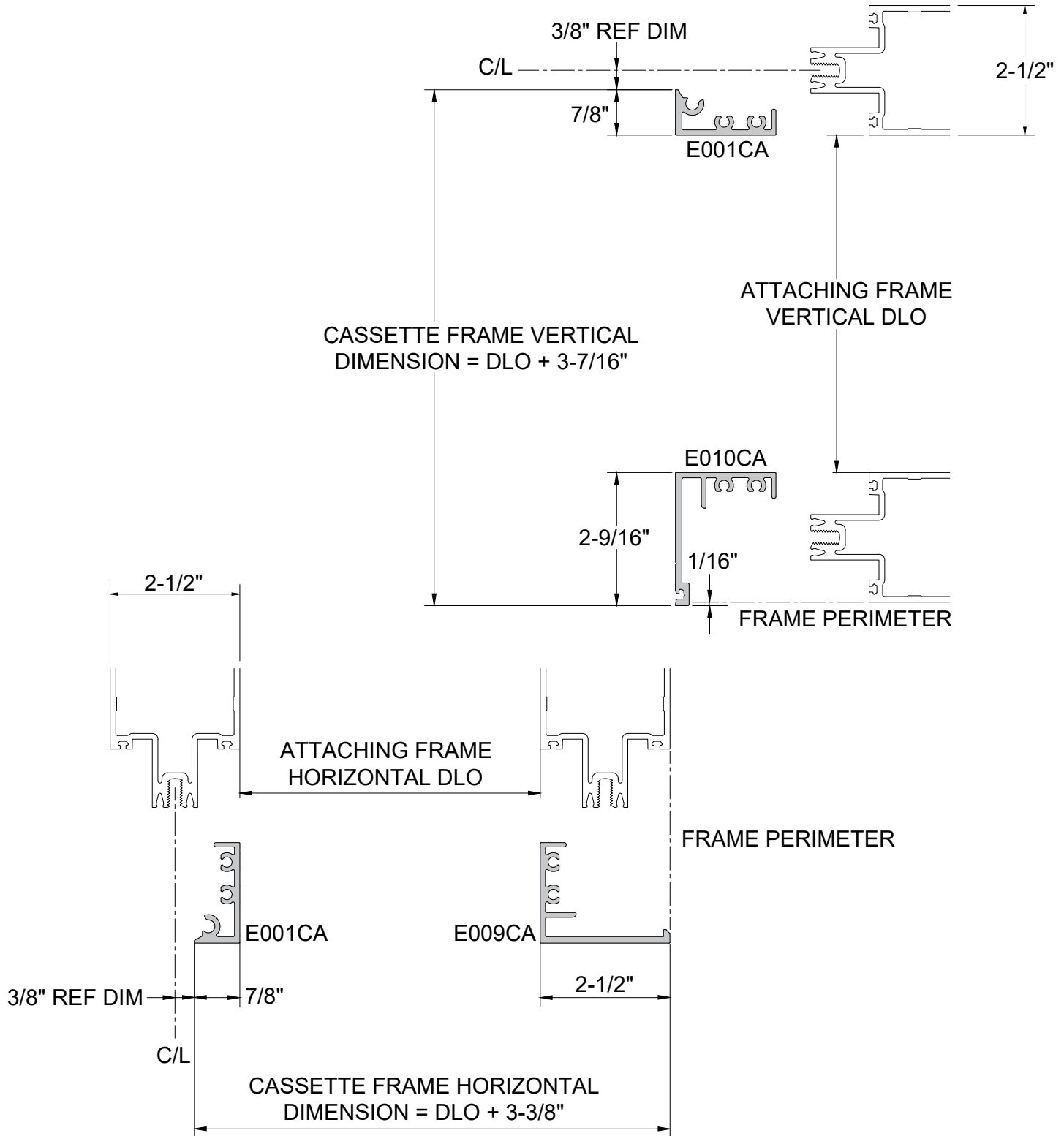

NOTE: Cassette frames sizes based on 400CW/T back members or 2-1/2" profile back members.

**CASSETTE FRAME CUT SIZE CALCULATOR -
 "Glass-to-Edge" Sill / Jamb**

Cassette frame member Vertical / Horizontal cut size:

Vertical frame member cut size = DLO of attaching frame

Horizontal frame member cut size = DLO plus 3-3/8" of attaching frame

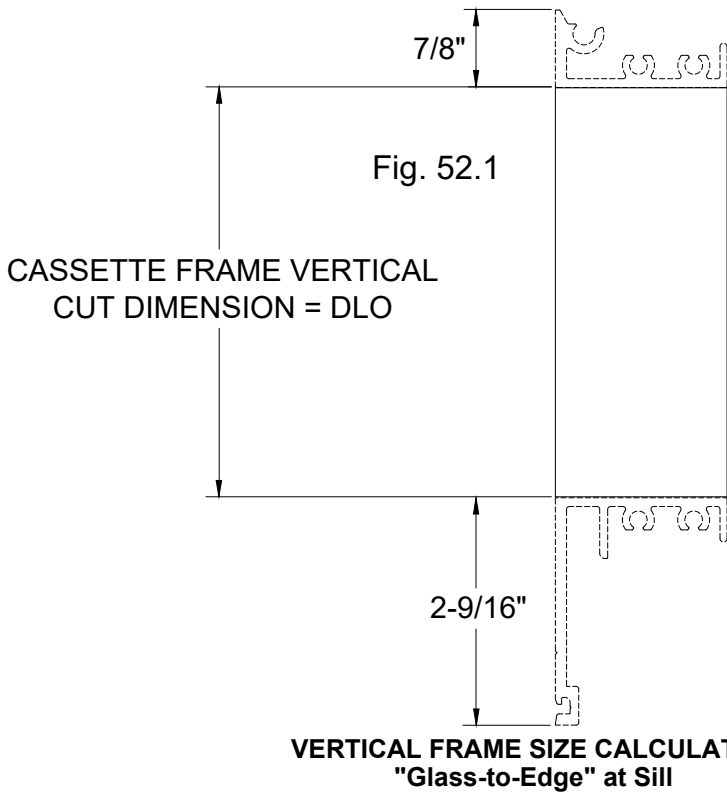

STEP 1: Cut cassette vertical (jamb) framing members E001CA and E009CA to calculated lengths. Fig. 52.1.

STEP 2: Cut cassette horizontal (head / sill) framing members E001CA and E010CA to calculated lengths.

STEP 3: Cope one end of head and sill frame to match Fig. 52.2. This end will be intermediate jamb side.

STEP 4: Cope other end of head and sill frame to match Fig. 52.3. This will be the "Glass-to-Edge" jamb side.

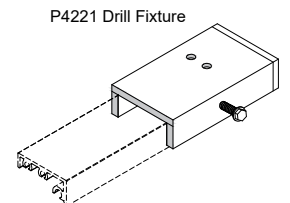
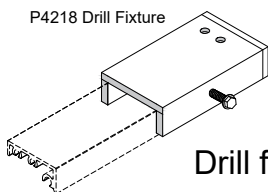
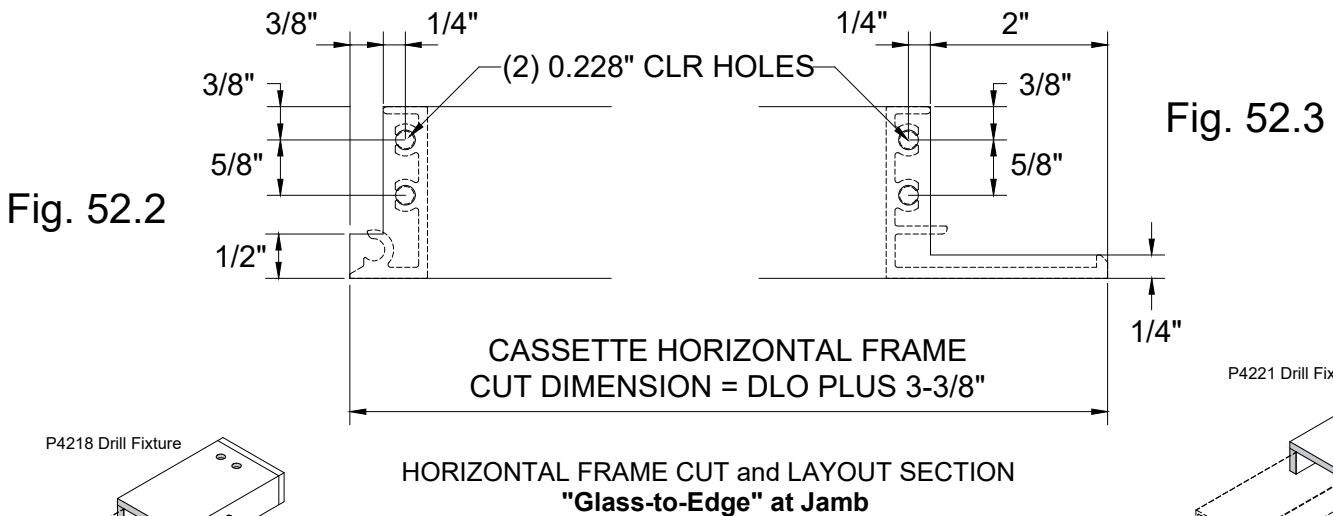

Drill fixtures P4218 and P4221 are available for assembly hole location.

CASSETTE GLASS SIZE CALCULATOR -

"Glass-to-Edge" Sill / Jamb

Cassette frame overall glass size:

Vertical glass size = Back member DLO plus 3"

Horizontal glass size = Back member DLO plus 3-3/8"

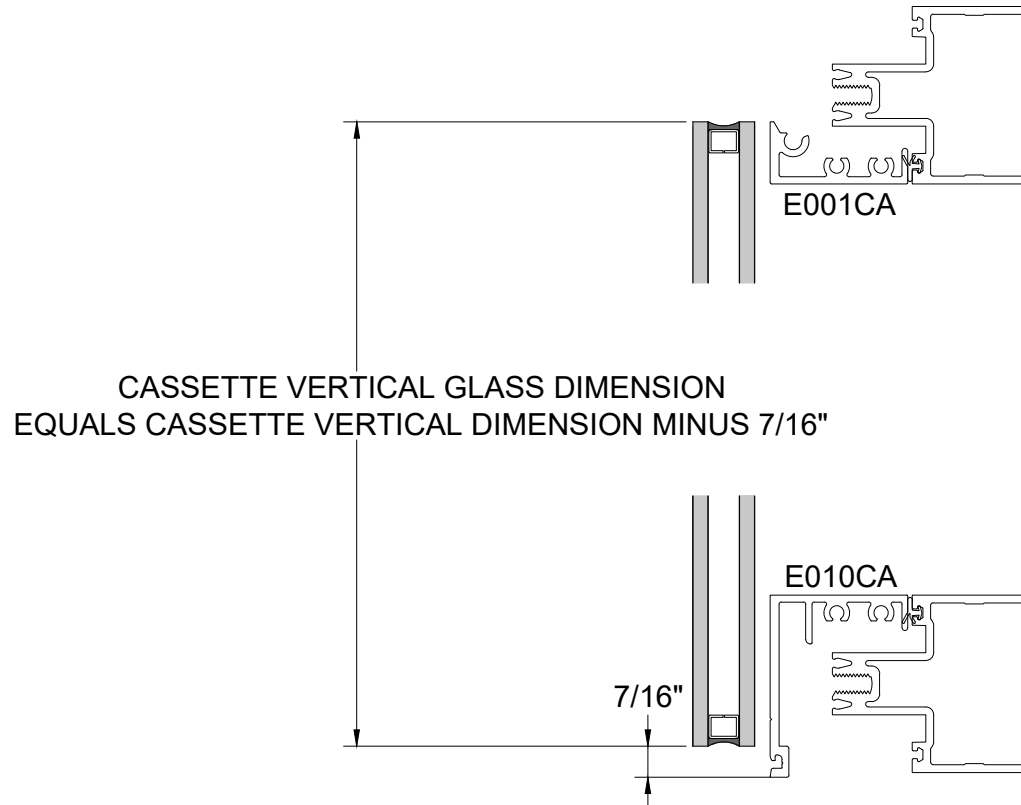

CASSETTE VERTICAL GLASS DIMENSION
EQUALS CASSETTE VERTICAL DIMENSION MINUS 7/16"

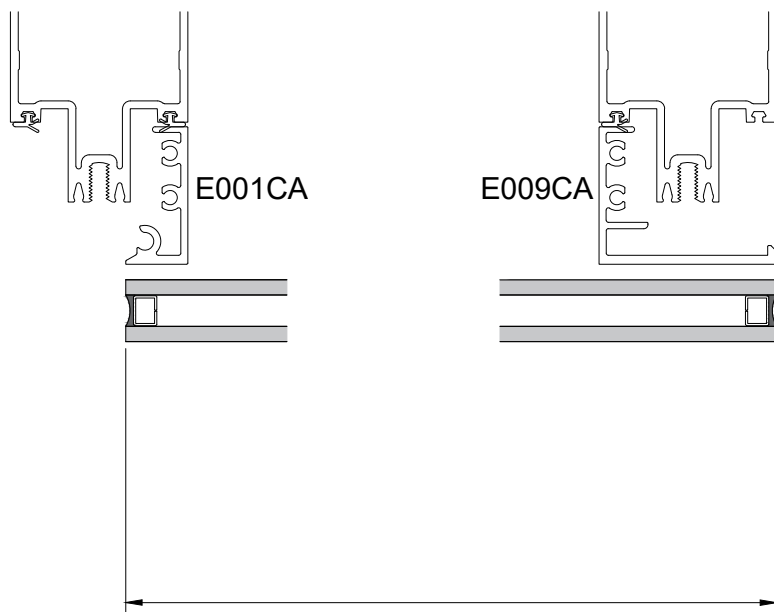

CASSETTE HORIZONTAL GLASS DIMENSION
EQUALS CASSETTE HORIZONTAL DIMENSION

CASSETTE FRAME ASSEMBLY - "Glass-to-Edge" Sill / Jamb

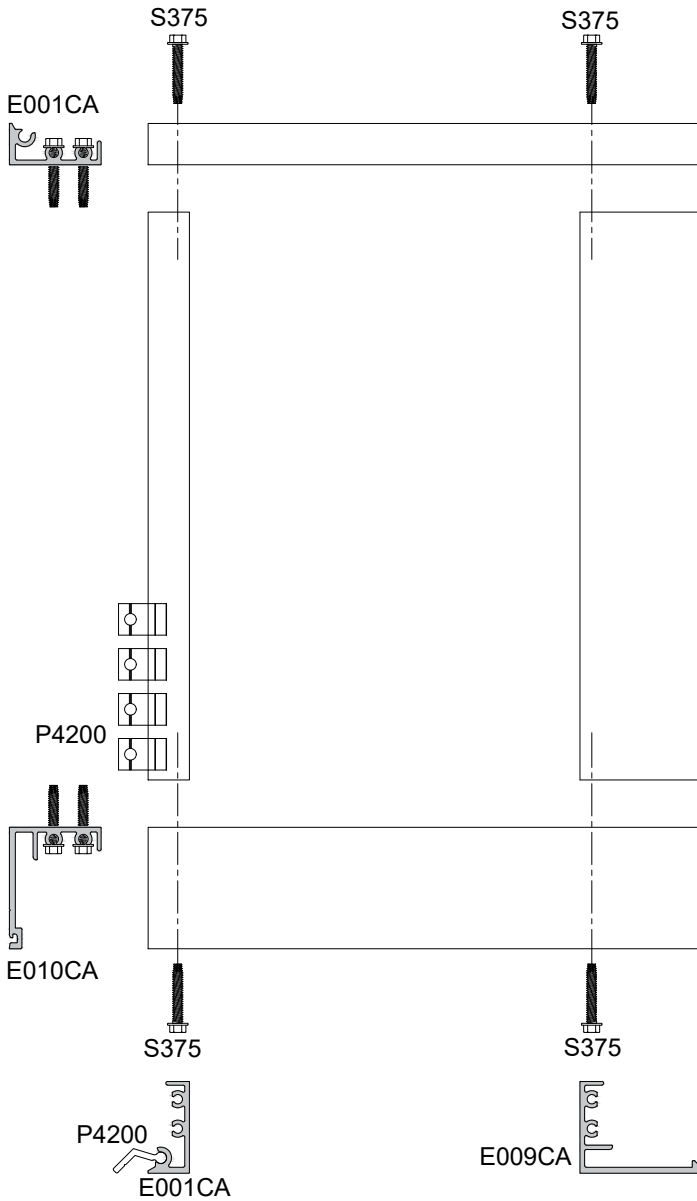

ALTERNATE JAMB ANCHOR INSTALLATION

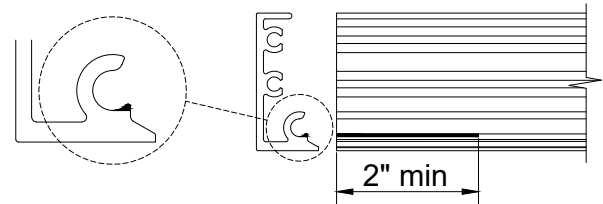

If the P4200 anchors are to be loaded in the jambs after the cassette frame had been assembled, the fabricator will need to remove the portion of the anchor receiver at the head of the jamb frames as shown above.

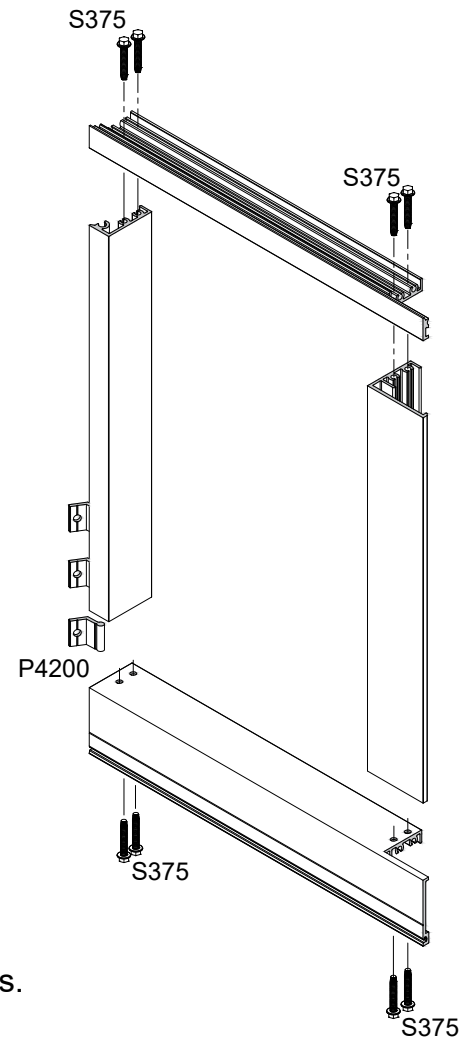

CASSETTE FRAME ASSEMBLY:

- STEP 1: Layout head, sill and jambs on table for assembly.
- STEP 2: Attach sill frame to jamb frames using S375 fasteners.
- STEP 3: Slide correct number of P4200 jamb anchors into jamb anchor receivers. Jamb anchor count equals overall jamb dimension divided by 12" plus one. (ex: 72" jamb equals 6 anchors plus one...7 total)
- STEP 4: Attach head frame to jamb frames using S375 fasteners completing frame assembly.

CASSETTE FRAME GLAZING - "Glass-to-Edge" Sill / Jamb

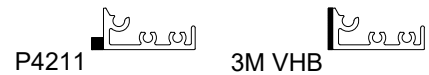
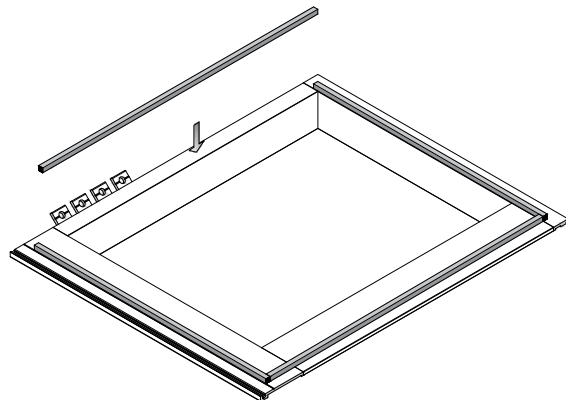

Apply tape at "V" groove at sill and jamb. Follow DLO at head and opposite jamb.

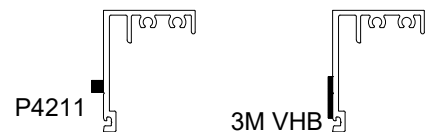

NOTE: If using 3M VHB glazing tape contact 3M for training certification and approvals.

CASSETTE GLAZING PREP and GLASS INSTALLATION

- STEP 1: Lay assembled cassette frame on glazing table and square frame, hold frame in square position.
- STEP 2: Using Isopropyl 70/30 mixture two towel wipe, clean face of cassette frame that will glazed against.
- STEP 3: Install P4211 (1/4" x 1/4") Norton tape adhesive side to cassette face.
- STEP 4: Using Isopropyl 70/30 mixture two towel wipe, clean surface of glass that will come in contact with silicone.
- STEP 5: Set glass to frame aligning edges of glass with frame.
(note: glass size will vary, balance overage / under around frame)

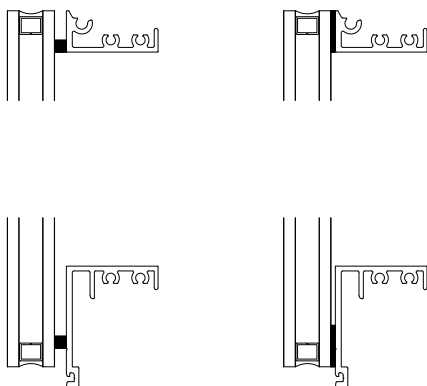
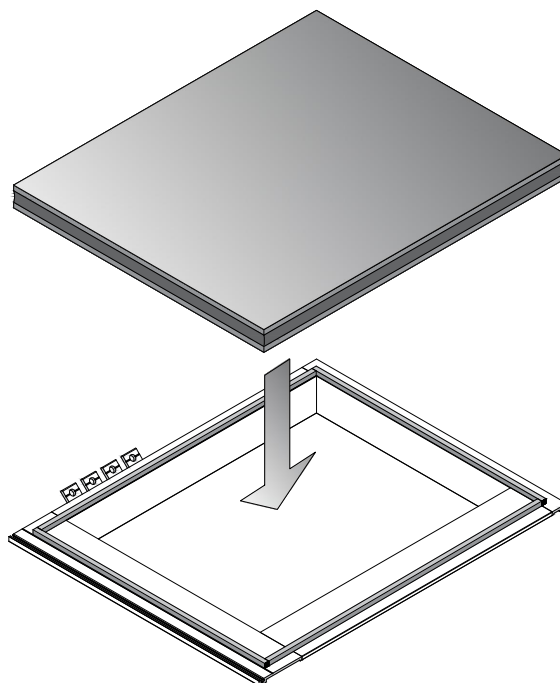

CASSETTE FRAME GLAZING - "Glass-to-Edge" Sill / Jamb cont.

CASSETTE SSG GLAZING

NOTE: Glazing contractor is responsible for selection and proper installation of silicone for glass to cassette attachment / glazing. Follow manufacturer's recommendations for application...environmental conditions, curing time and handling.
(Dow 995 was used by Tubelite for performance mock up)

- STEP 1: Fill void between cassette frame and glass with silicone.
- STEP 2: Tool silicone around perimeter of frame.
- STEP 3: Install setting block chair P4623 and setting block P1912S at quarter points. (Use setting block chair P4226 and setting block P4603 at quarter points when using VHB tape glazing.)
- STEP 4: Move unit making sure not to disturb glass / cassette frame and let cure per manufactures' recommendations.

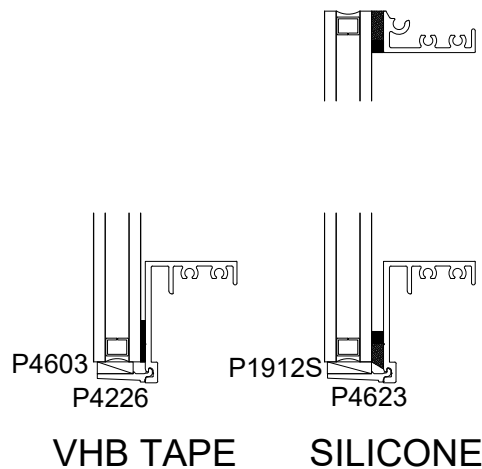

CASSETTE FRAME INSTALLATION - "Glass-to-Edge" Sill / Jamb

- STEP 1: Install dead load blocking P4213 between sill anchor clips P4223.
- STEP 2: Set sill of assembled cassette frame on anchor clips P4223 as shown at Fig. 57.1. Note location of jamb frame position shown at Fig. 57.3
- STEP 3: Roll head of frame toward back member support framing as shown at Fig. 57.2.
- STEP 4: Once cassette frame is in vertical position slide frame towards "Glass-to-Edge" jamb sliding frame into jamb anchor...see Fig 57.4.
- STEP 5: Install and attach head anchor clips P4202, 12" o/c, maximum 2" from ends. See Fig. 57.2
- STEP 6: Attach pre-installed jamb anchor clips P4200, 12" o/c, maximum 2" from ends.

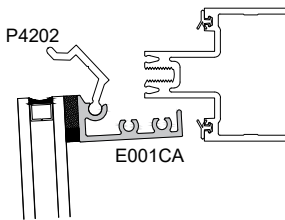

Fig. 57.1

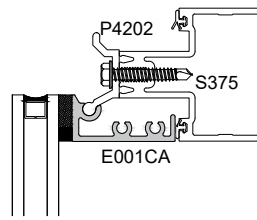

Fig. 57.2

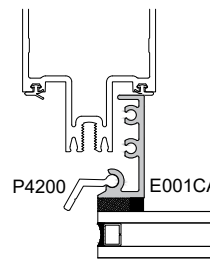

Fig. 57.3

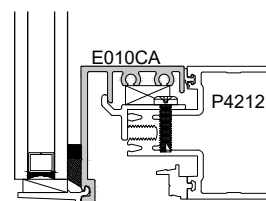
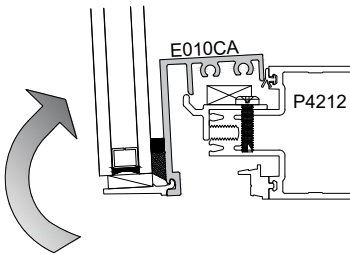
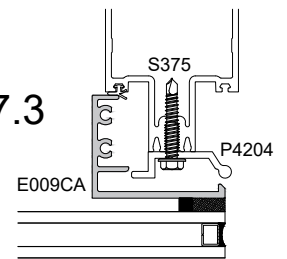
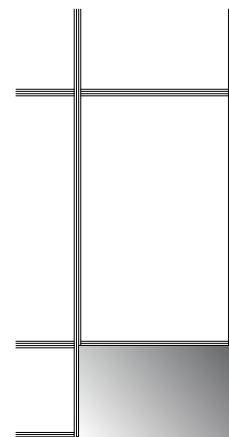
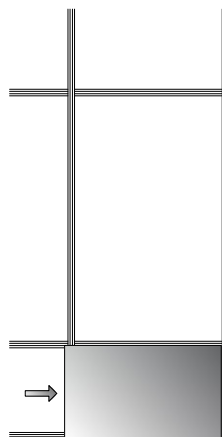
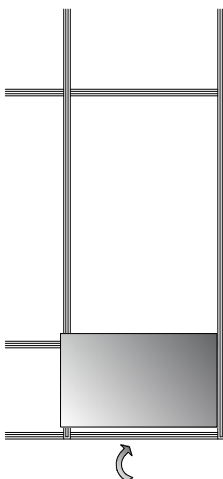
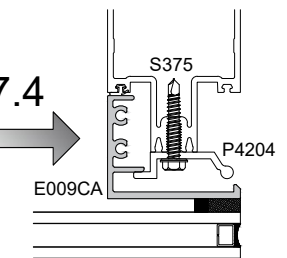
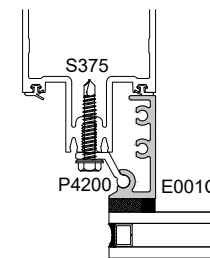

Fig. 57.4



Partial elevation showing cassette frame movements for installation

**CASSETTE FRAME SIZE CALCULATOR -
"Glass-to-Edge" Jamb**

Cassette frame overall dimension:

Vertical frame dimension: Back member DLO plus 1-3/4"

Horizontal frame dimension: Back member frame DLO plus 2-3/8"

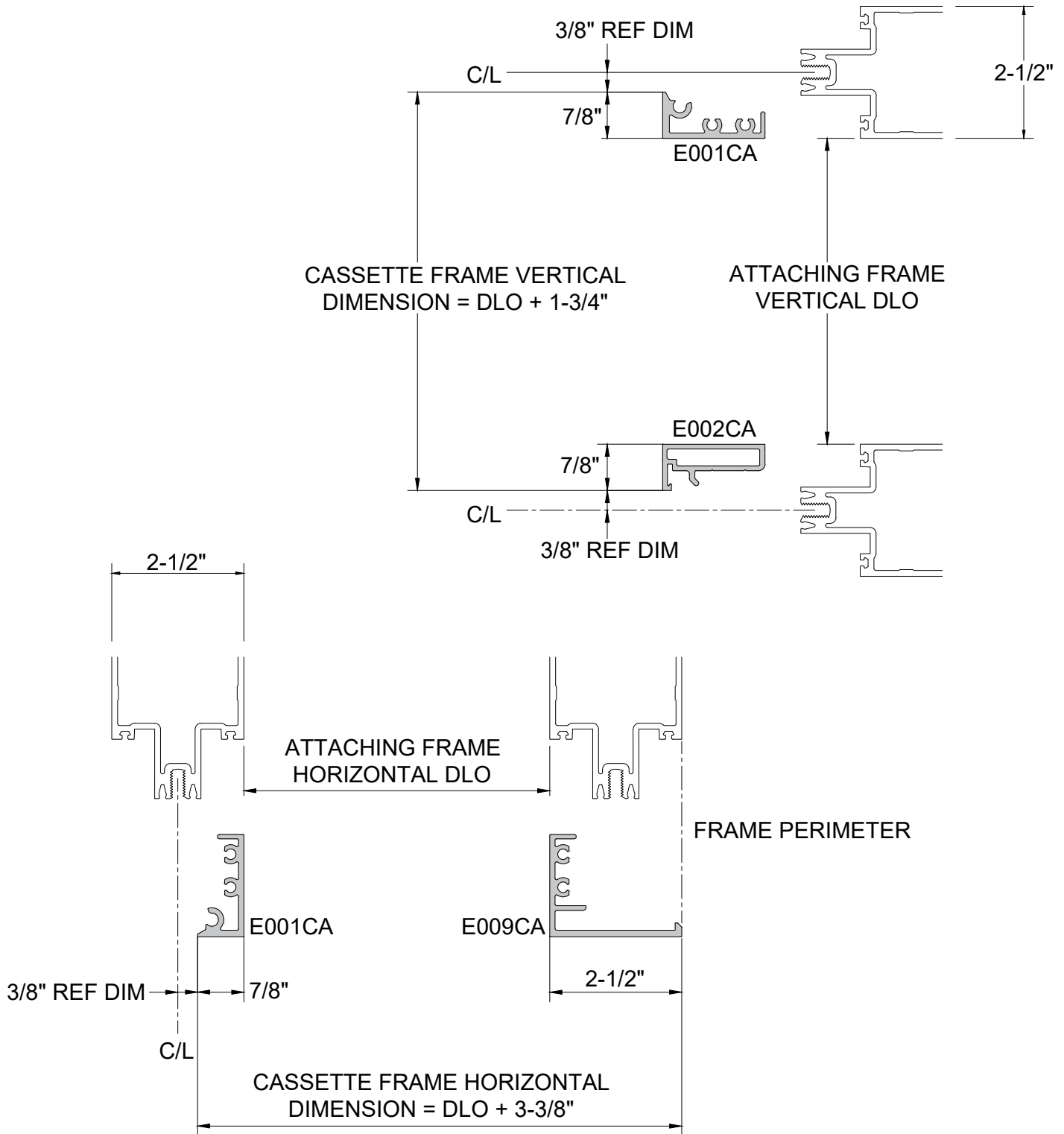

NOTE: Cassette frames sizes based on 400CW/T back members or 2-1/2" profile back members.

**CASSETTE FRAME CUT SIZE CALCULATOR -
 "Glass-to-Edge" Jamb**

Cassette frame member Vertical / Horizontal cut size:

Vertical frame member cut size = DLO of attaching frame

Horizontal frame member cut size = DLO plus 2-3/8" of attaching frame

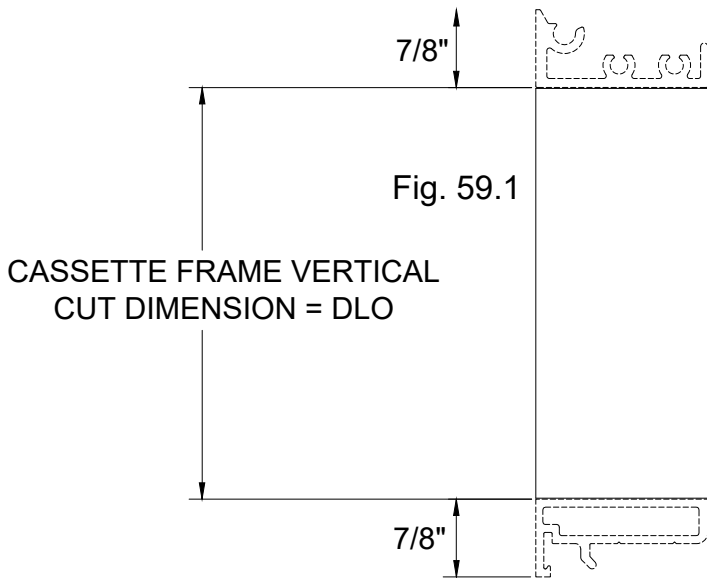

VERTICAL FRAME SIZE CALCULATOR

- STEP 1: Cut cassette vertical (jamb) framing members E001CA and E009CA to calculated lengths. Fig. 59.1.
- STEP 2: Cut cassette horizontal (head / sill) framing members E001CA and E002CA to calculated lengths.
- STEP 3: Cope one end of head and sill frame to match Fig. 59.2. This end will be intermediate jamb side.
- STEP 4: Cope other end of head and sill frame to match Fig. 59.3. This will be the "Glass-to-Edge" jamb side.

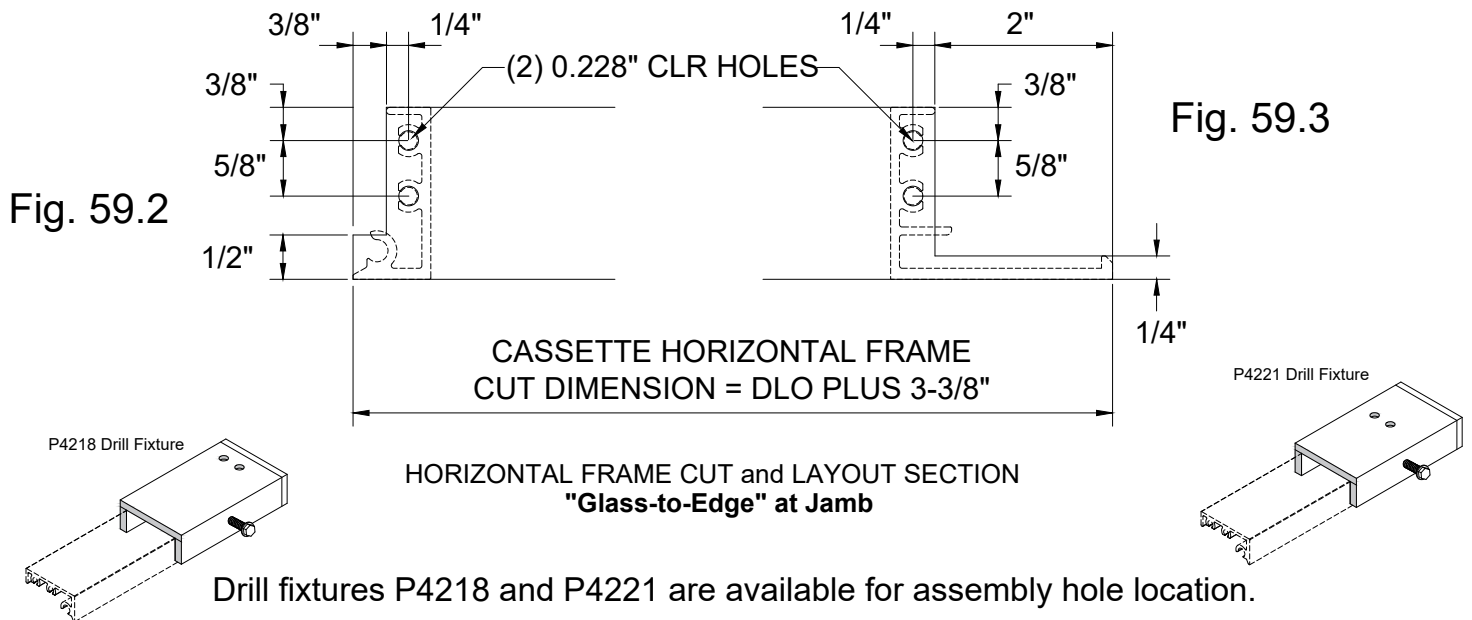

Drill fixtures P4218 and P4221 are available for assembly hole location.

CASSETTE GLASS SIZE CALCULATOR -

"Glass-to-Edge" Jamb

Cassette frame overall glass size:

Vertical glass size = Back member DLO plus 1-3/4"

Horizontal glass size = Back member DLO plus 3-3/8"

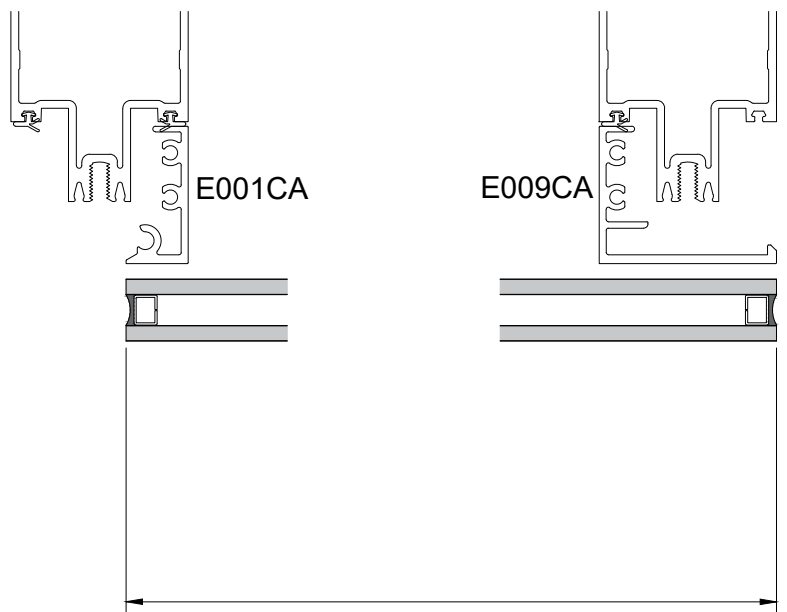
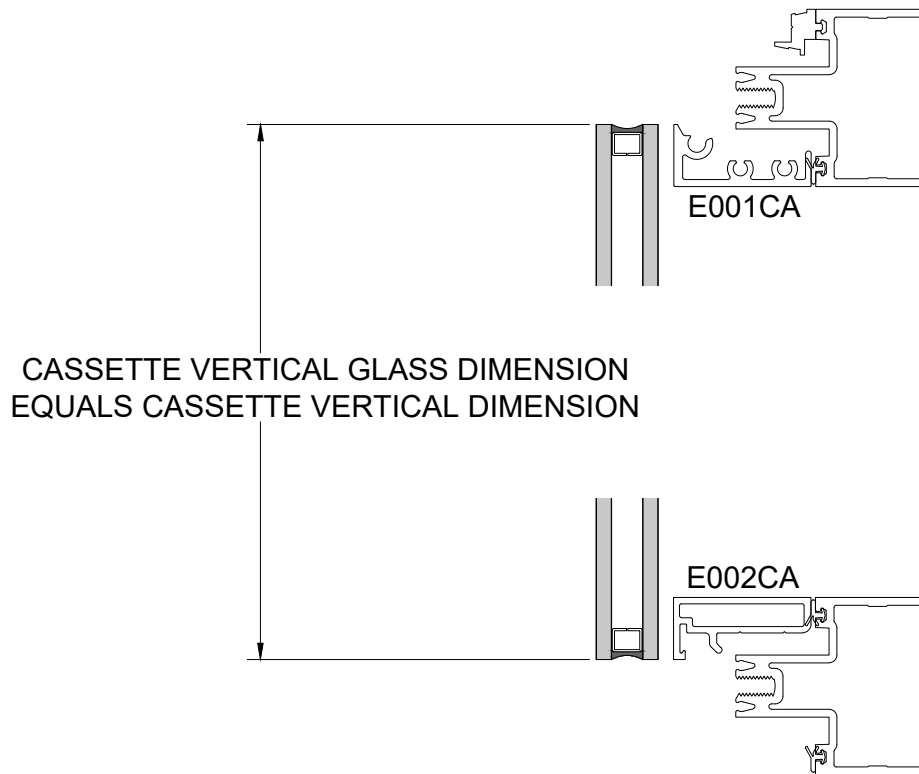

CASSETTE HORIZONTAL GLASS DIMENSION
EQUALS CASSETTE HORIZONTAL DIMENSION

CASSETTE FRAME ASSEMBLY - "Glass-to-Edge" Jamb

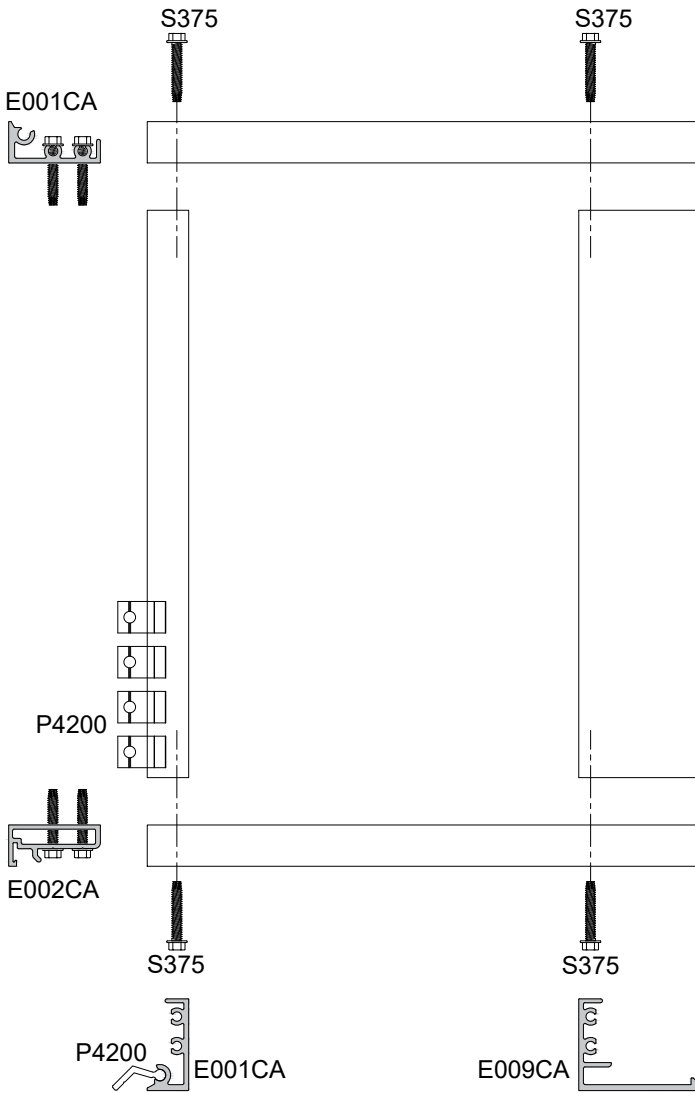

ALTERNATE JAMB ANCHOR INSTALLATION

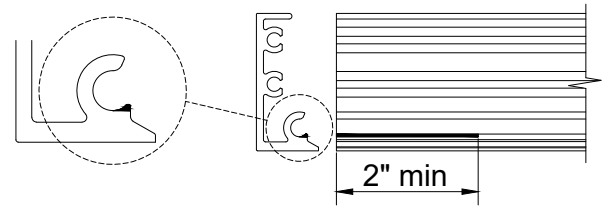

If the P4200 anchors are to be loaded in the jambs after the cassette frame had been assembled, the fabricator will need to remove the portion of the anchor receiver at the head of the jamb frames as shown above.

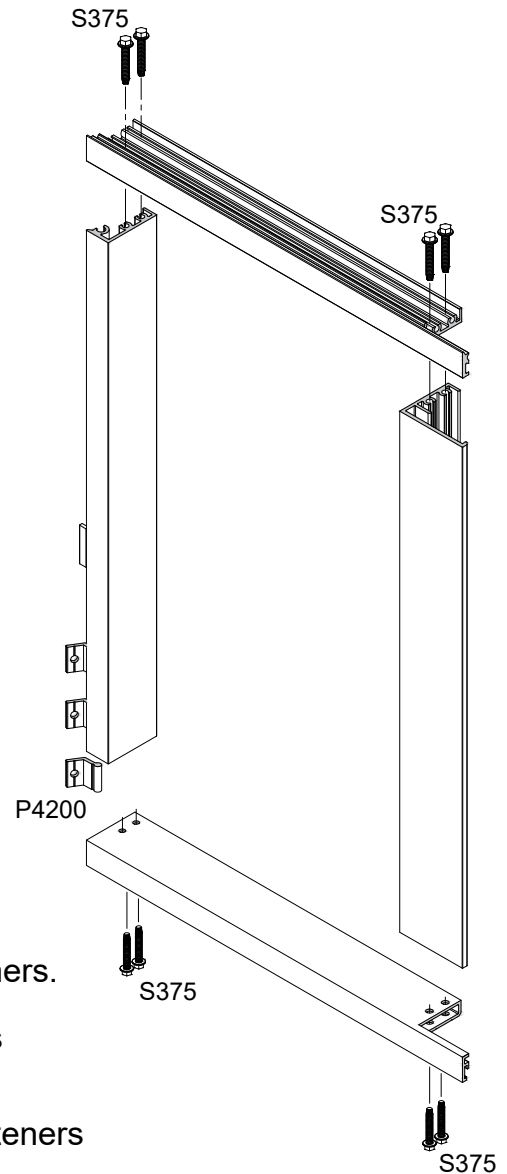

CASSETTE FRAME ASSEMBLY:

- STEP 1: Layout head, sill and jambs on table for assembly.
- STEP 2: Attach sill frame to jamb frames using S375 fasteners.
- STEP 3: Slide correct number of P4200 jamb anchors into jamb anchor receivers. Jamb anchor count equals overall jamb dimension divided by 12" plus one. (ex: 72" jamb equals 6 anchors plus one...7 total)
- STEP 4: Attach head frame to jamb frames using S375 fasteners completing frame assembly.

CASSETTE FRAME GLAZING - "Glass-to-Edge" Jamb

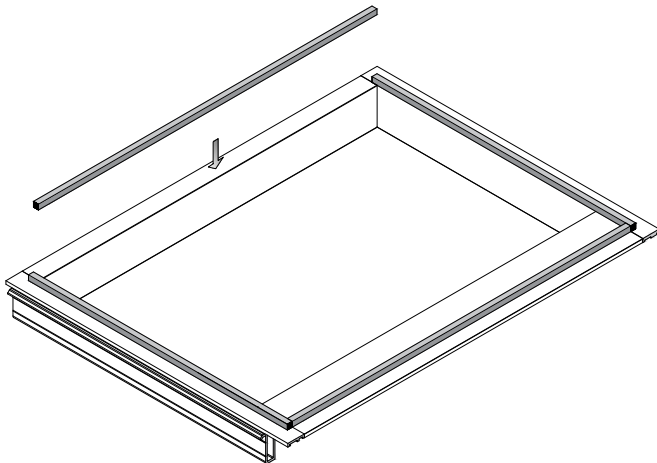

Apply tape at "V" groove at jamb. Follow DLO at head, sill and opposite jamb.

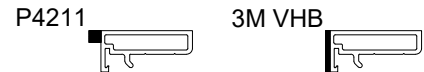

NOTE: If using 3M VHB glazing tape contact 3M for training certification and approvals.

CASSETTE GLAZING PREP and GLASS INSTALLATION

- STEP 1: Lay assembled cassette frame on glazing table and square frame, hold frame in square position.
- STEP 2: Using Isopropyl 70/30 mixture two towel wipe, clean face of cassette frame that will glazed against.
- STEP 3: Install P4211 (1/4" x 1/4") Norton tape adhesive side to cassette face.
- STEP 4: Using Isopropyl 70/30 mixture two towel wipe, clean surface of glass that will come in contact with silicone.
- STEP 5: Set glass to frame aligning edges of glass with frame.
(note: glass size will vary, balance overage / under around frame)

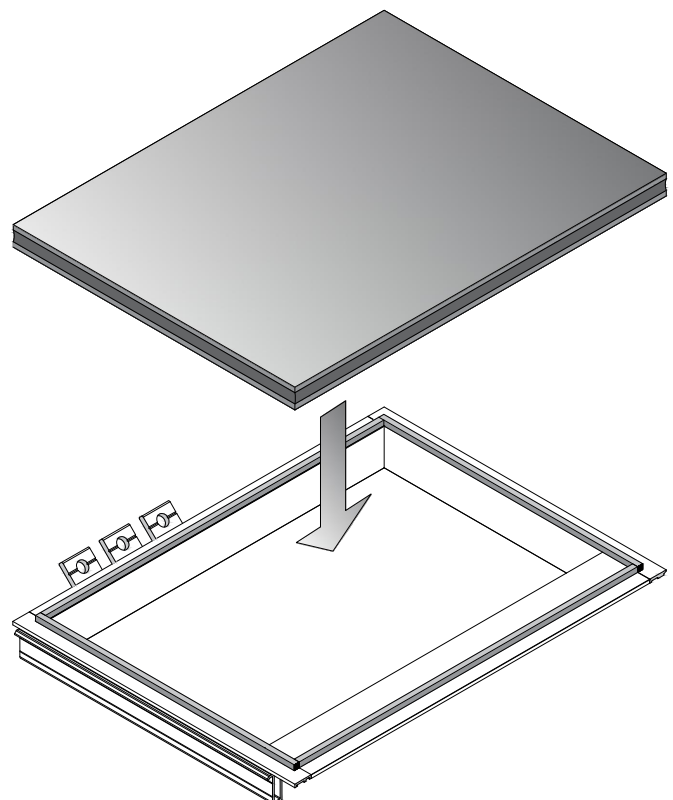
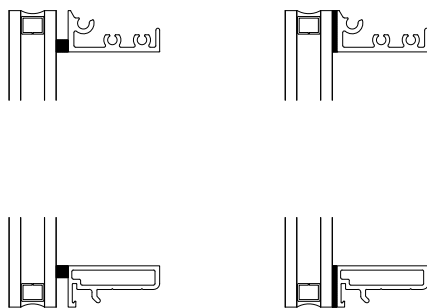

CASSETTE FRAME GLAZING - "Glass-to-Edge" Jamb cont.

CASSETTE SSG GLAZING

NOTE: Glazing contractor is responsible for selection and proper installation of silicone for glass to cassette attachment / glazing. Follow manufacturer's recommendations for application...environmental conditions, curing time and handling.
(Dow 995 was used by Tubelite for performance mock up)

- STEP 1: Fill void between cassette frame and glass with silicone.
- STEP 2: Tool silicone around perimeter of frame.
- STEP 3: Install setting block chair P4215 and setting block P1912S at quarter points. (Use setting block chair P4224 and setting block P4603 at quarter points when using VHB glazing tape.)
- STEP 4: Move unit making sure not to disturb glass / cassette frame and let cure per manufactures' recommendations.

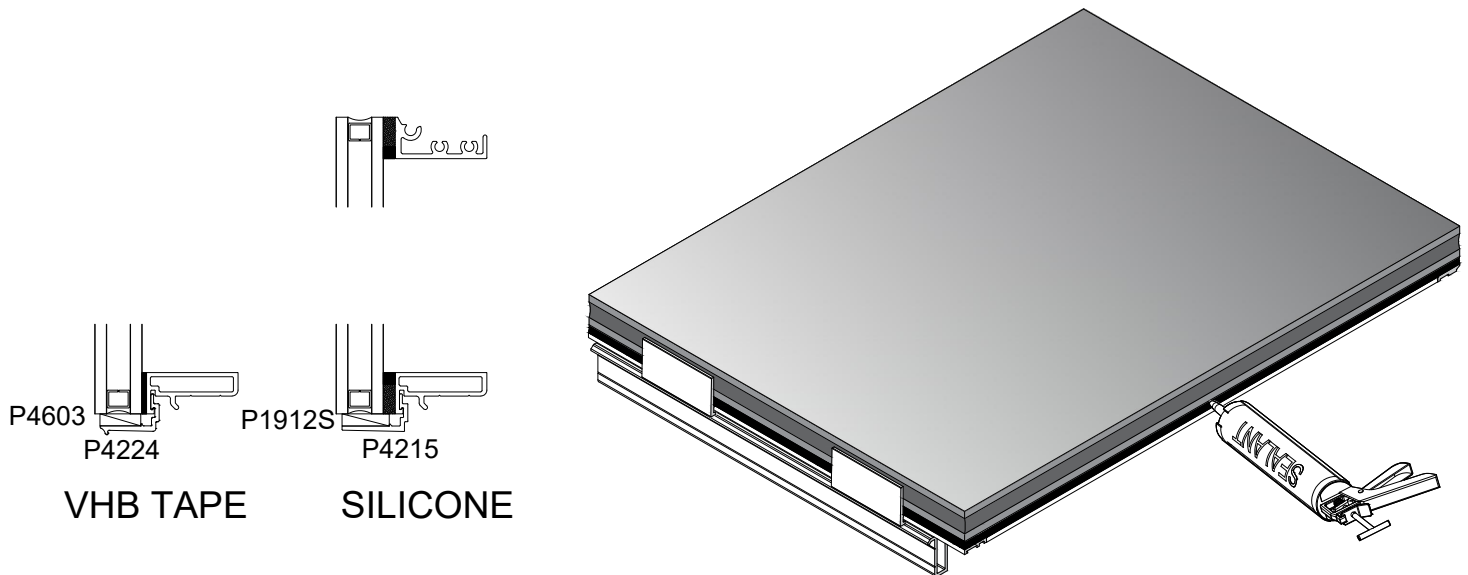

CASSETTE FRAME INSTALLATION - "Glass-to-Edge" Jamb

- STEP 1: Set sill of assembled cassette frame on anchor clips P4202 as shown at Fig. 64.1. Note location of jamb frame position shown at Fig. 64.3
- STEP 2: Roll head of frame toward back member support framing as shown at Fig. 64.2.
- STEP 3: Once cassette frame is in vertical position slide frame towards "Glass-to-Edge" jamb sliding frame into jamb anchor...see Fig 63.4.
- STEP 4: Install and attach head anchor clips P4202, 12" o/c, maximum 2" from ends. See Fig. 64.2
- STEP 5: Attach pre-installed jamb anchor clips P4200, 12" o/c, maximum 2" from ends.

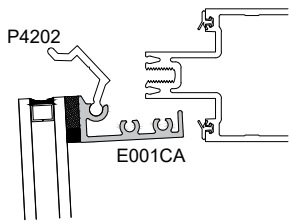

Fig. 64.1

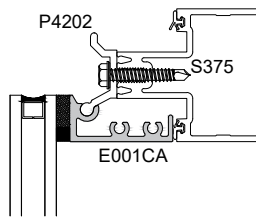

Fig. 64.2

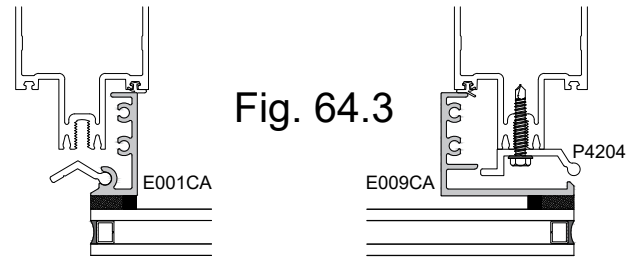

Fig. 64.3

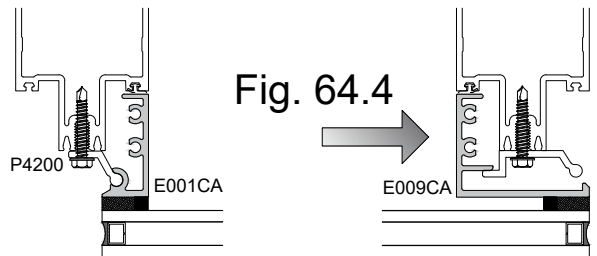
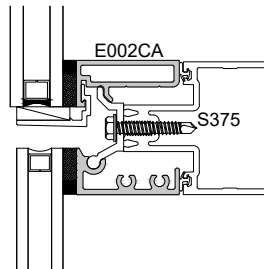
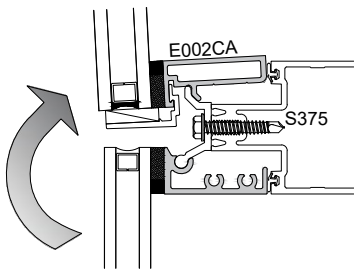
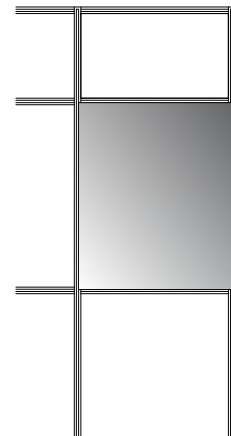
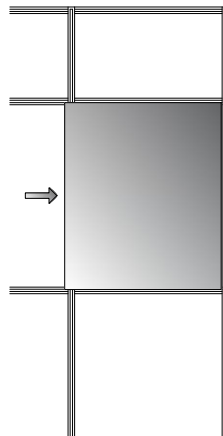
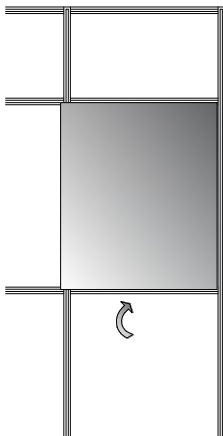

Fig. 64.4



Partial elevation showing cassette frame movements for installation

CASSETTE FRAME SIZE CALCULATOR - Outside Corner

Cassette frame overall dimension:

Vertical frame dimension: Back member DLO plus 1-3/4"

Horizontal frame dimension: Back member frame DLO plus 4-1/8"

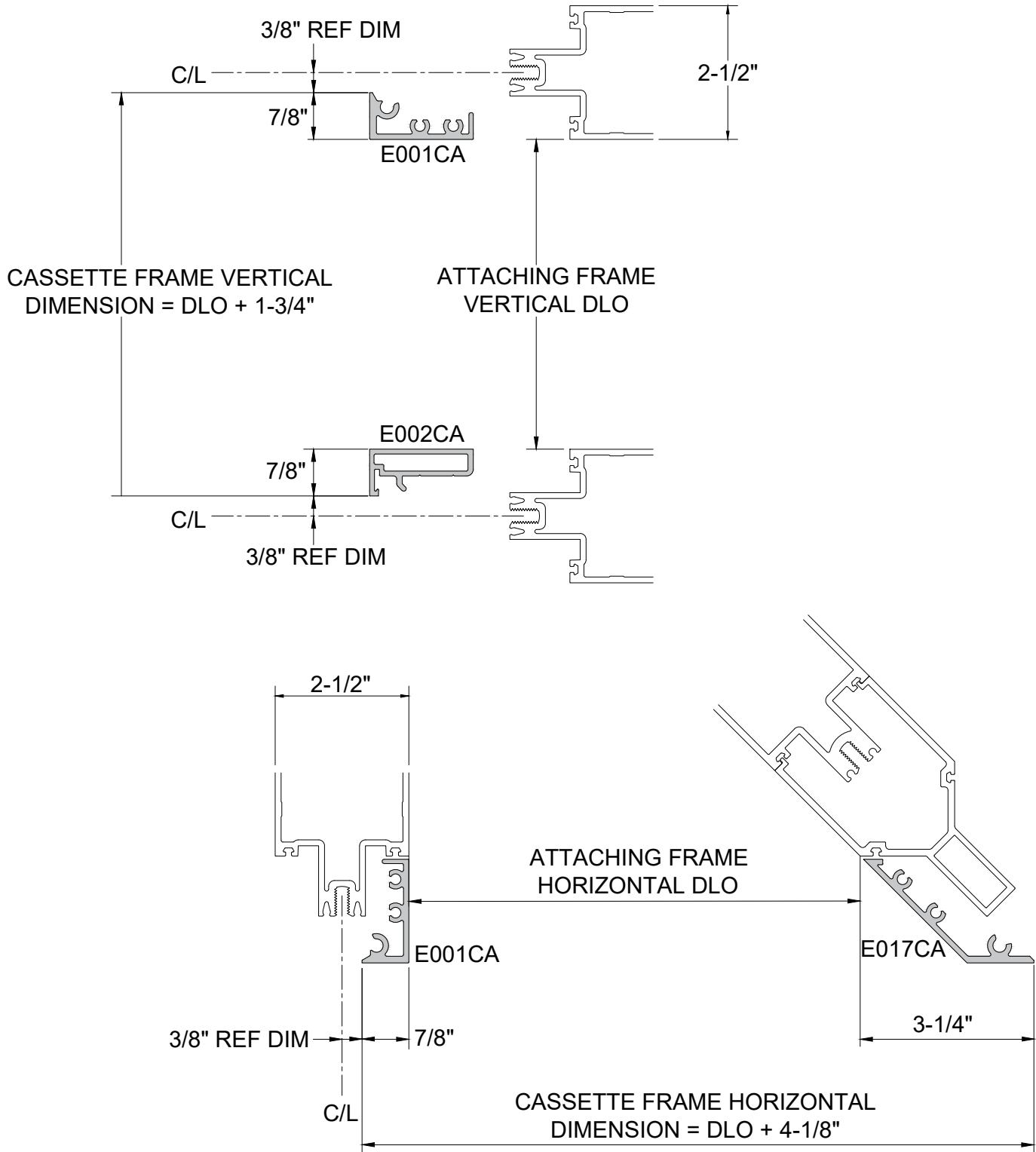

NOTE: Cassette frames sizes based on 400CW/T back members or 2-1/2" profile back members.

CASSETTE FRAME CUT SIZE CALCULATOR - Outside Corner

Cassette frame member Vertical / Horizontal cut size:

Vertical frame member cut size = DLO of attaching frame

Horizontal frame member cut size = DLO of attaching frame plus 4-1/8"

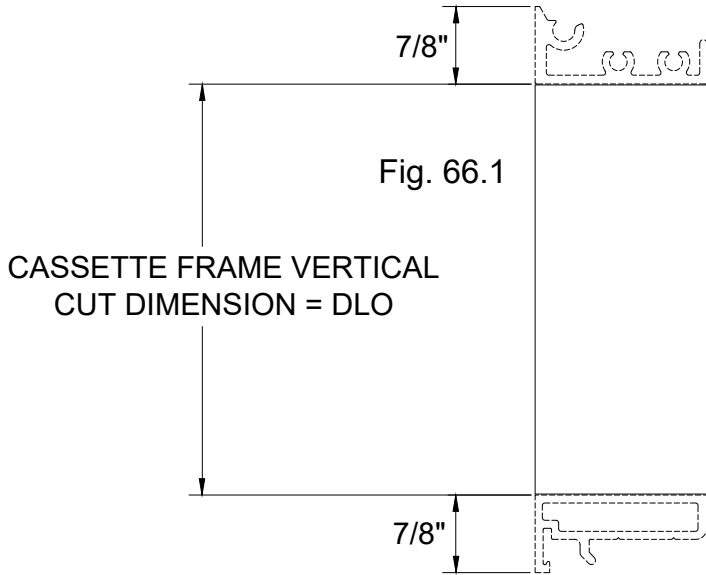

VERTICAL FRAME SIZE CALCULATOR

- STEP 1: Cut cassette vertical (jamb) framing members E001CA and E017CA to calculated lengths. Fig. 66.1.
- STEP 2: Cut cassette horizontal (head / sill) framing members E001CA and E002CA to calculated lengths.
- STEP 3: Miter and prep one end of head and sill frame to match Fig. 66.2. This end will be intermediate jamb side.
- STEP 4: Miter and prep other end of head and sill frame to match Fig. 66.3. This will be the outside jamb side.

Fig. 66.2

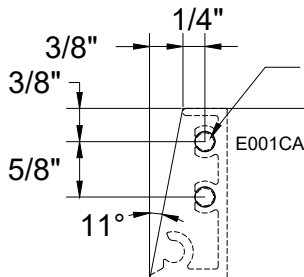
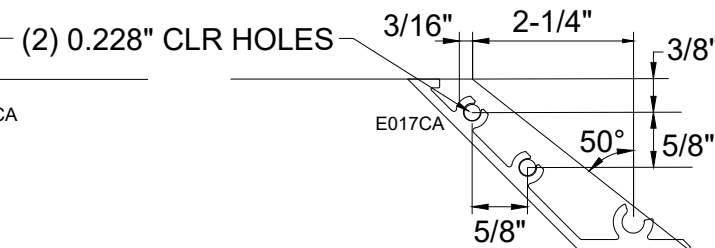

Fig. 66.3



(2) 0.228 CLR HOLES

CASSSETTE HORIZONTAL FRAME CUT DIMENSION = DLO PLUS 4-1/8"

HORIZONTAL FRAME CUT and LAYOUT SECTION Outside Corner

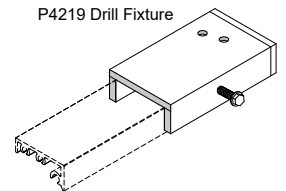
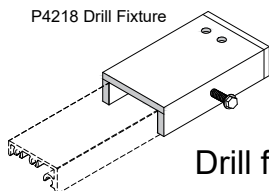

Drill fixtures P4218 and P4219 are available for assembly hole location.

CASSETTE GLASS SIZE CALCULATOR

Cassette frame overall glass size:

Vertical glass size = Back member DLO plus 1-3/4"

Horizontal glass size = Back member DLO plus 5-1/8"

Note: Outside glass lite extends past interior light 3/4".

This 3/4" is included in overall horizontal glass size.

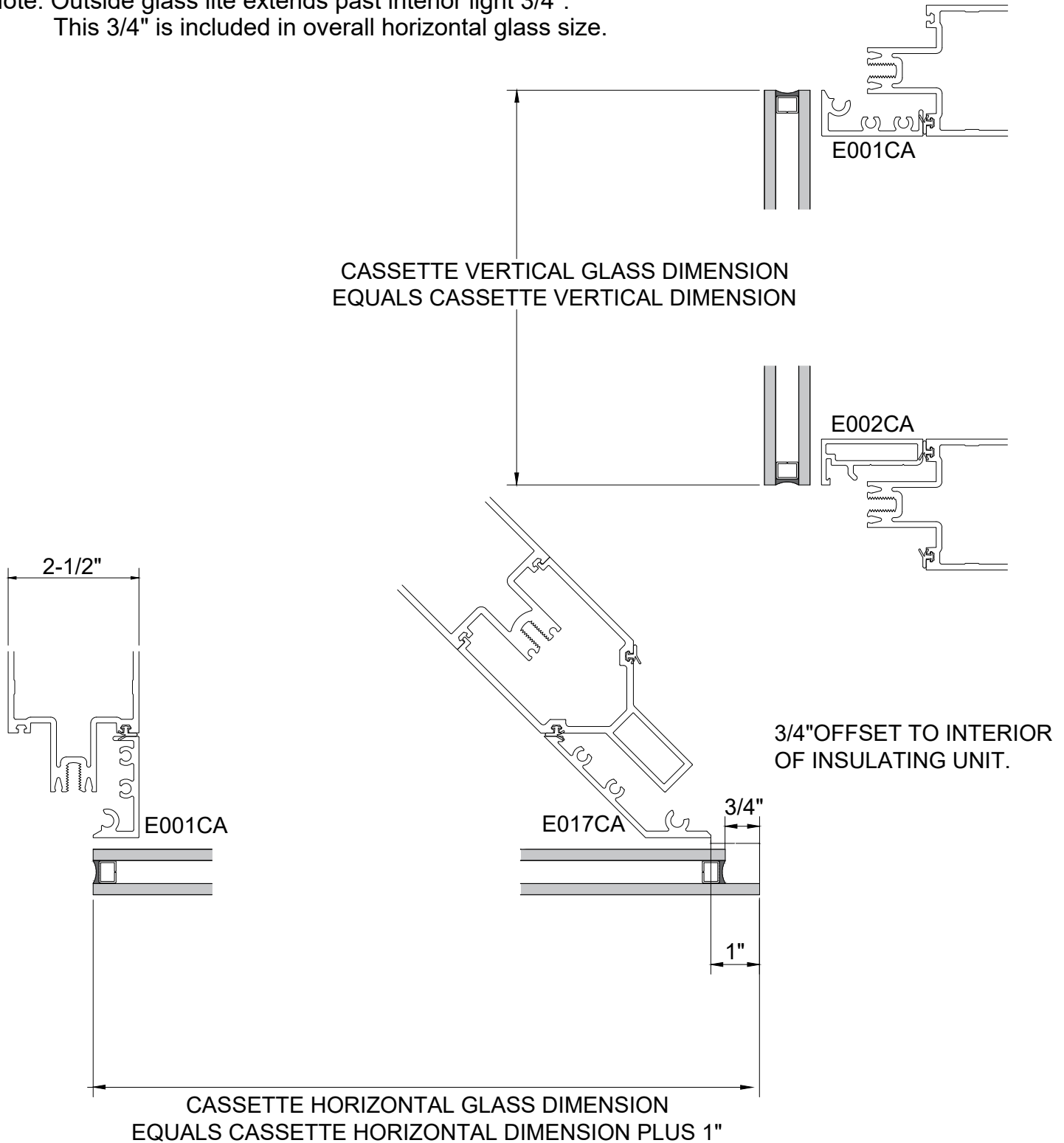

CASSETTE FRAME ASSEMBLY - Outside Corner

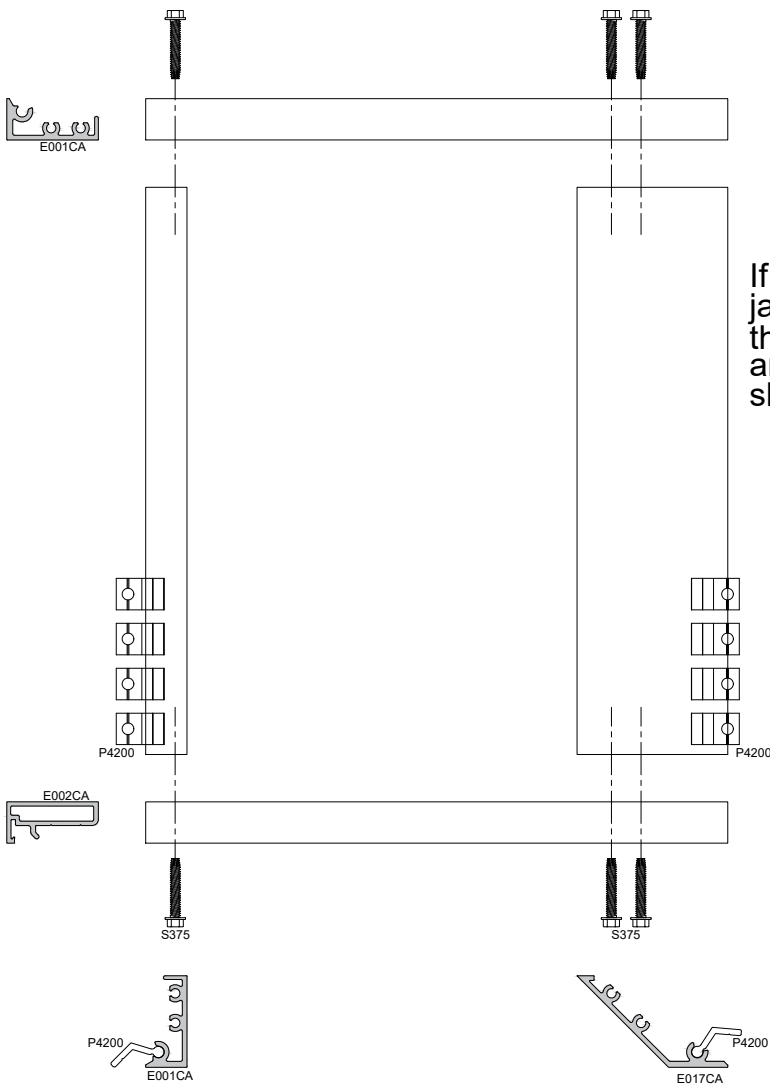

ALTERNATE JAMB ANCHOR INSTALLATION

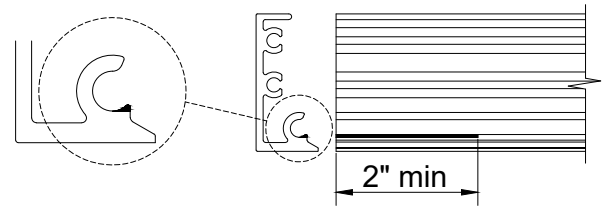

If the anchors are to be loaded in the jambs after the cassette frame had been assembled, the fabricator will need to remove the portion of the anchor receiver at the head of the jamb frames as shown above.

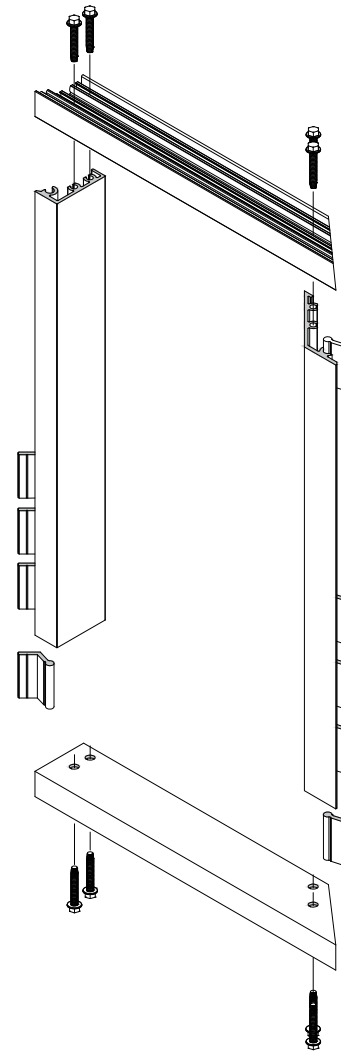

CASSETTE FRAME ASSEMBLY:

- STEP 1: Layout head, sill and jambs on table for assembly.
- STEP 2: Attach sill frame to jamb frames using S375 fasteners.
- STEP 3: Slide correct number of P4200 jamb anchors into jamb anchor receivers. Jamb anchor count equals overall jamb dimension divided by 12" plus one. (ex: 72" jamb equals 6 anchors plus one...7 total)
- STEP 4: Attach head frame to jamb frames using S375 fasteners completing frame assembly.

CASSETTE FRAME GLAZING - Outside Corner

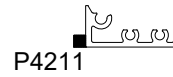
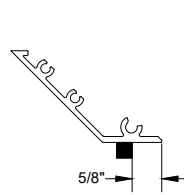
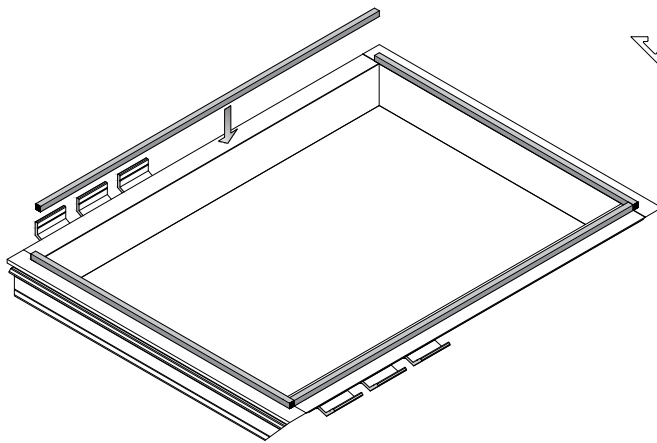

Apply tape 5/8" back from corner jamb and follow DLO at head, sill and opposite jamb.

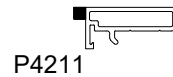

NOTE: If using 3M VHB glazing tape contact 3M for training certification and approvals.

CASSETTE GLAZING PREP and GLASS INSTALLATION

- STEP 1: Lay assembled cassette frame on glazing table and square frame, hold frame in square position.
- STEP 2: Using Isopropyl 70/30 mixture two towel wipe clean face of cassette frame that will glazed against.
- STEP 3: Install P4211 (1/4" x 1/4") Norton tape adhesive side to cassette face.
- STEP 4: Using Isopropyl 70/30 mixture two towel wipe clean surface of glass that will come in contact with silicone.
- STEP 5: Set glass to frame aligning edges of glass with frame.
(note: glass size will vary, balance overage / under around frame)

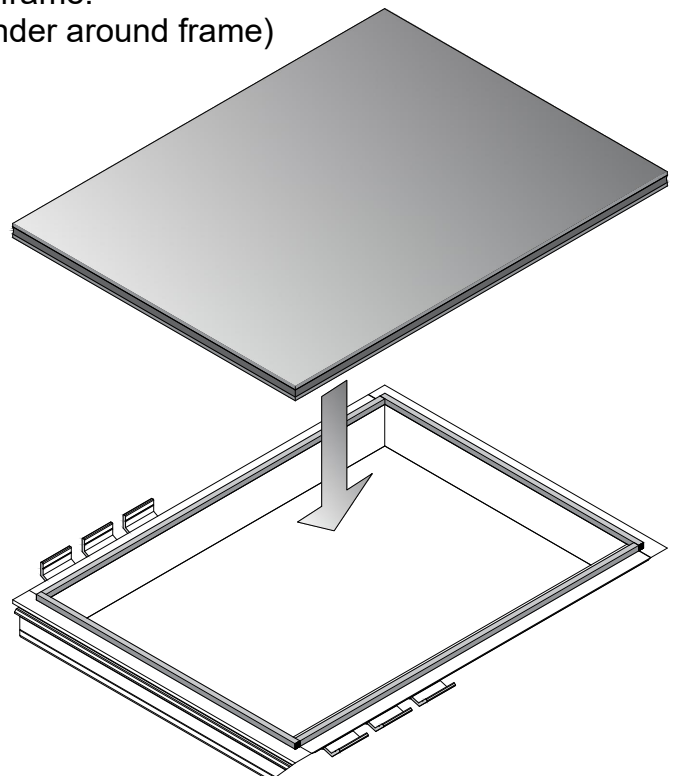
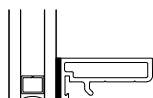
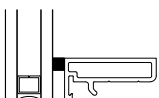
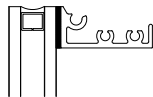
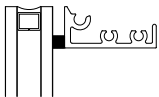

CASSETTE FRAME GLAZING - Outside Corner, cont.

CASSETTE SSG GLAZING

NOTE: Glazing contractor is responsible for selection and proper installation of silicone for glass to cassette attachment / glazing. Follow manufacturer's recommendations for application...environmental conditions, curing time and handling.
(Dow 995 was used by Tubelite for performance mock up)

- STEP 1: Fill void between cassette frame and glass with silicone.
- STEP 2: Tool silicone around perimeter of frame.
- STEP 3: Install setting block chair P4215 and setting block P1912S at quarter points. (Use setting block chair P4224 and setting block P4603 at quarter points when using VHB tape glazing.)
- STEP 4: Move unit making sure not to disturb glass / cassette frame and let cure per manufactures' recommendations.

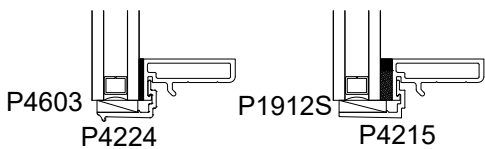
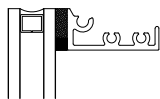
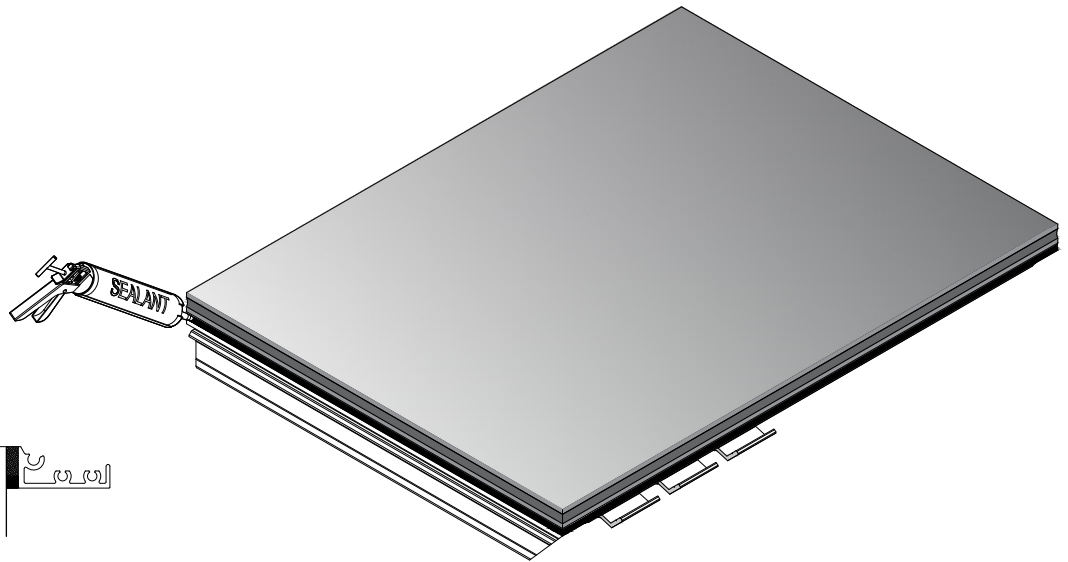

VHB TAPE

SILICONE

CASSETTE FRAME SIZE CALCULATOR - Inside Corner

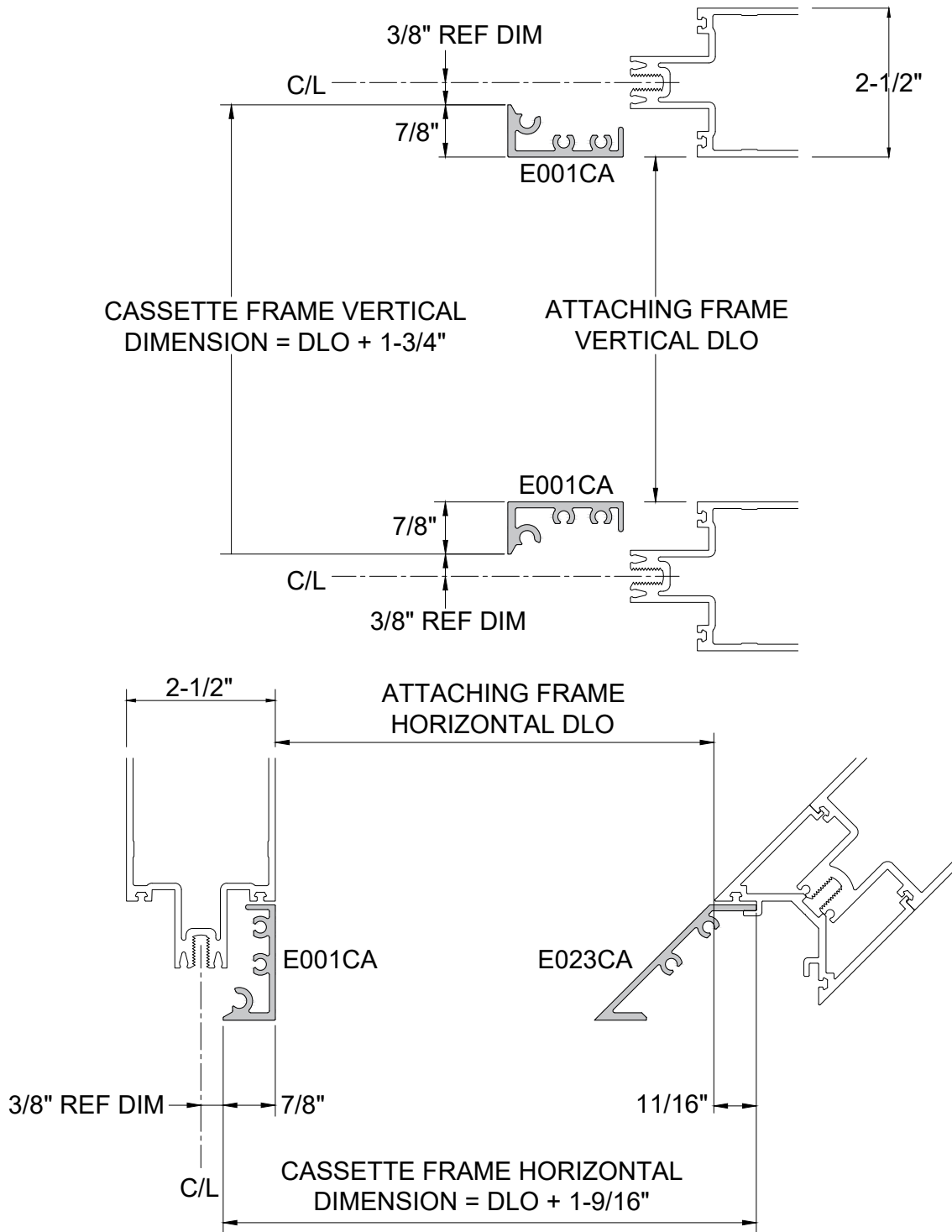

NOTE: Cassette frames sizes based on 400CW/T back members or 2-1/2" profile back members.

CASSETTE FRAME CUT SIZE CALCULATOR - Inside Corner

Cassette frame member Vertical / Horizontal cut size:

Vertical frame member cut size = DLO of attaching frame PLUS 1-11/16"

Horizontal frame member cut size = DLO of attaching frame

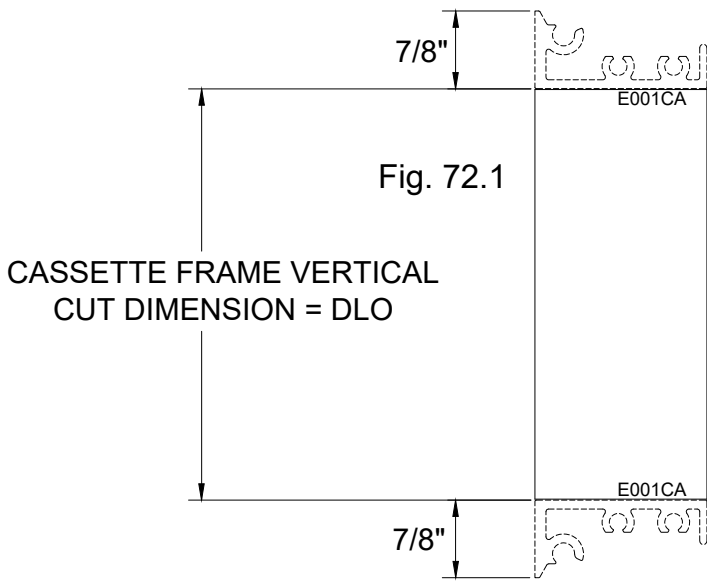

VERTICAL FRAME SIZE CALCULATOR

STEP 1: Cut cassette vertical (jamb) framing members E001CA and E023CA to calculated lengths as shown in Fig.72.1.

STEP 2: Cut cassette horizontals (head / sill) framing members E001CA to calculated lengths.

STEP 3: Cope one end of head and sill framing as shown in Fig. 72.2. This will be the intermediate jamb side.

STEP 4: Miter the opposite end of the head and sill framing members as shown in Fig. 72.3. this will be the inside corner jamb member.

STEP 5: Cut off ends of inside corner jamb members head and sill as shown in Fig. 72.4.

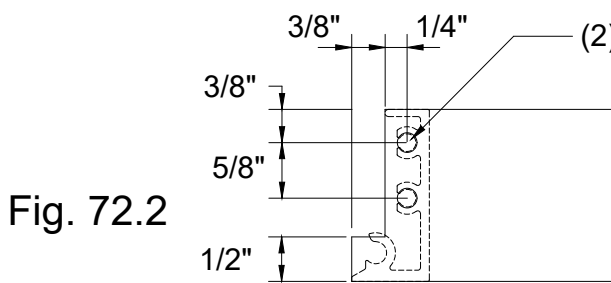
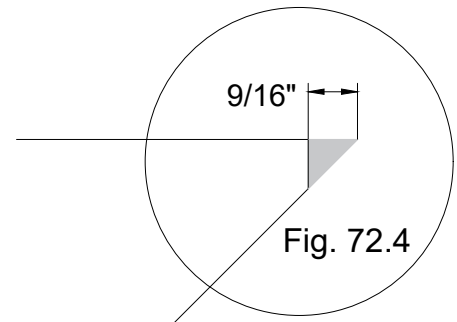

Fig. 72.2

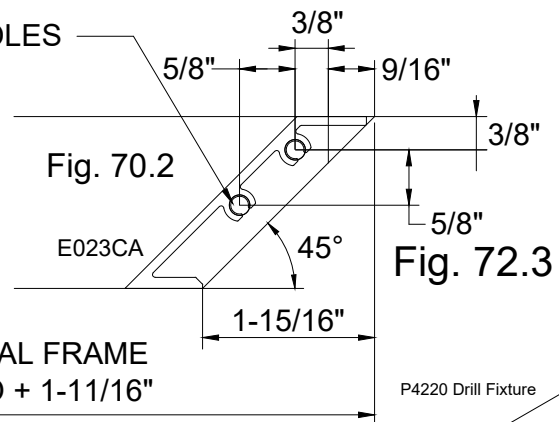
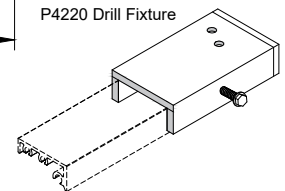
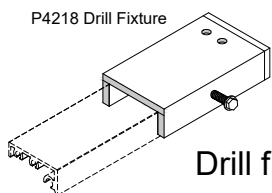

Fig. 72.3

CASSETTE HORIZONTAL FRAME CUT DIMENSION = DLO + 1-11/16"

HORIZONTAL FRAME CUT and LAYOUT SECTION Inside Corner



Drill fixtures P4218 and P4220 are available for assembly hole location.

CASSETTE GLASS SIZE CALCULATOR - Inside Corner

Cassette frame overall glass size:

Vertical glass size = Back member DLO PLUS 1-3/4"

Horizontal glass size = Back member DLO PLUS 3/4"

Note: Interior glass lite extends past exterior light 1/2".
This 1/2" is included in overall horizontal glass size.

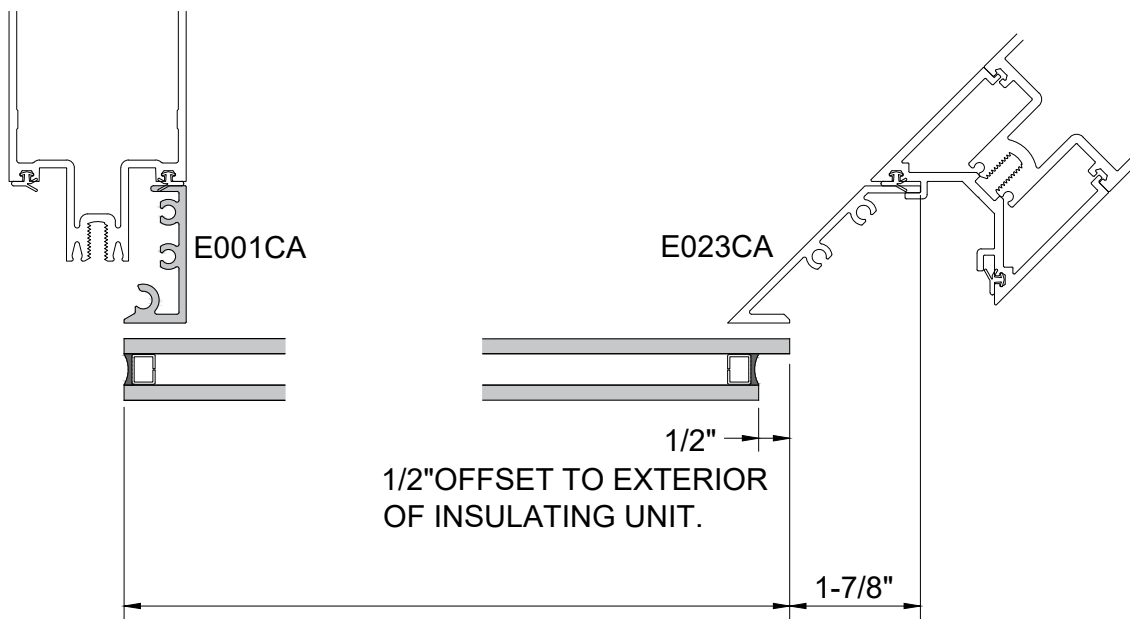
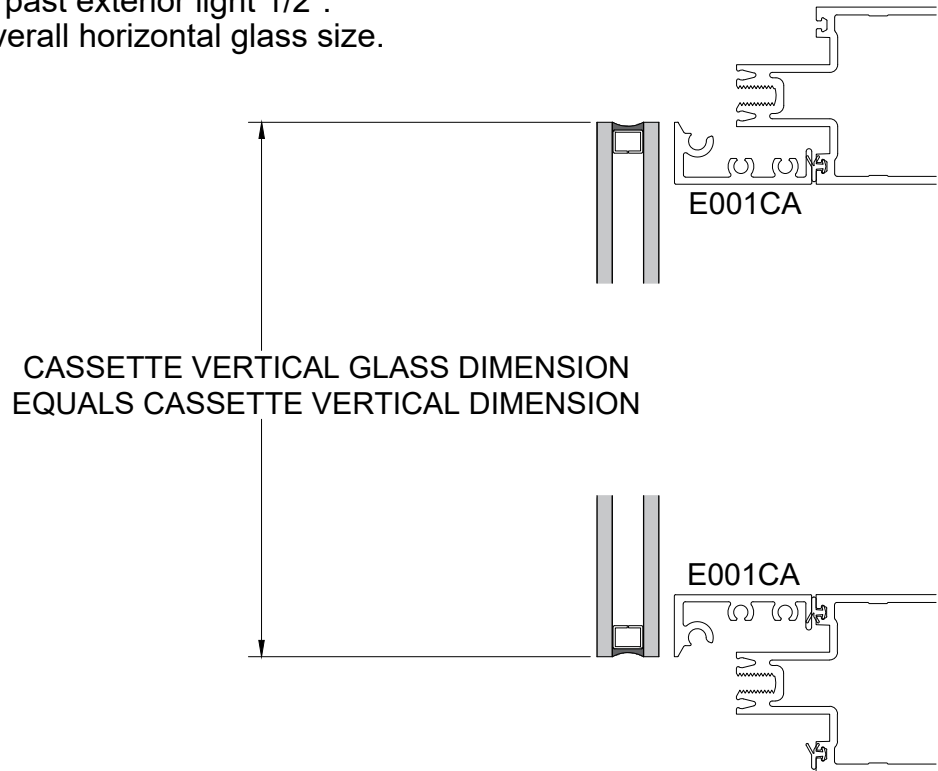

CASSETTE FRAME ASSEMBLY - Inside Corner

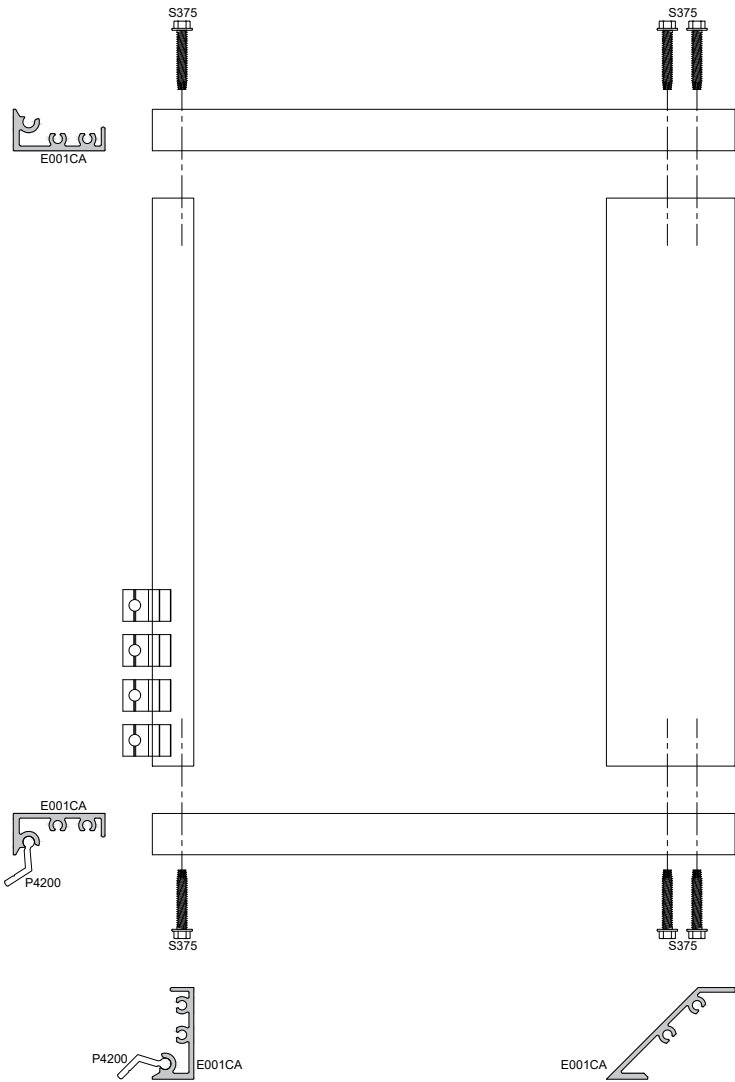

ALTERNATE JAMB ANCHOR INSTALLATION

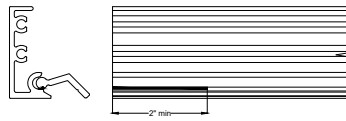

If the P4200 anchors are to be loaded in the jambs after the cassette frame had been assembled, the contractor will need to remove the portion of the anchor receiver at the head of the jamb frames as shown above.

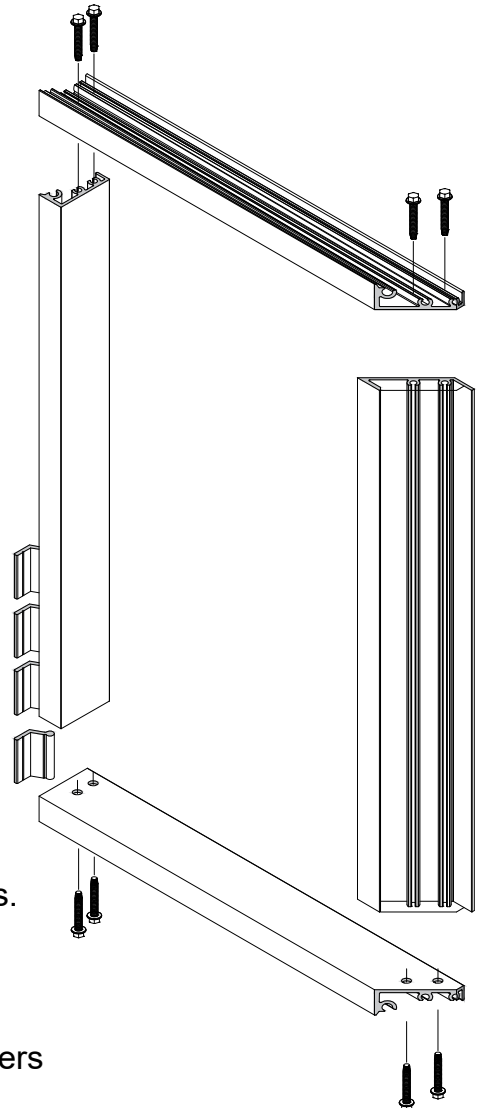

CASSETTE FRAME ASSEMBLY:

- STEP 1: Layout head, sill and jambs on table for assembly.
- STEP 2: Attach sill frame to jamb frames using S375 fasteners.
- STEP 3: Slide correct number of P4200 jamb anchors into jamb anchor receivers. Jamb anchor count equals overall jamb dimension divided by 12" plus one. (ex: 72" jamb equals 6 anchors plus one...7 total)
- STEP 4: Attach head frame to jamb frames using S375 fasteners completing frame assembly.

CASSETTE FRAME GLAZING - Inside Corner

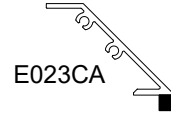
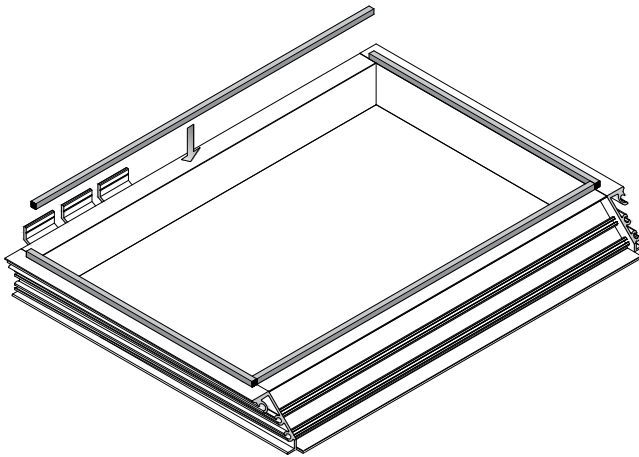

Apply tape at DLO on all four side of frame.

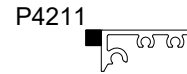

NOTE: If using 3M VHB glazing tape contact 3M for training certification and approvals.

CASSETTE GLAZING PREP and GLASS INSTALLATION

- STEP 1: Lay assembled cassette frame on glazing table and square frame, hold frame in square position.
- STEP 2: Using Isopropyl 70/30 mixture two towel wipe clean face of cassette frame that will glazed against.
- STEP 3: Install P4211 (1/4" x 1/4") Norton tape adhesive side to cassette face.
- STEP 4: Using Isopropyl 70/30 mixture two towel wipe clean surface of glass that will come in contact with silicone.
- STEP 5: Set glass to frame aligning edges of glass with frame.
(note: glass size will vary, balance overage / under around frame)

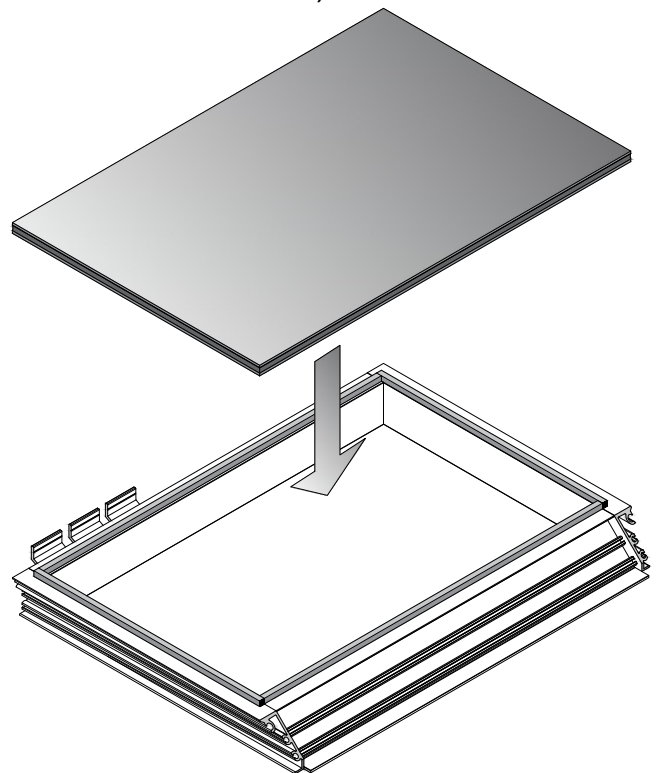
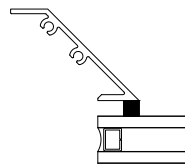
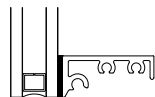
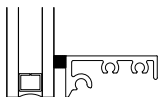
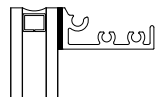
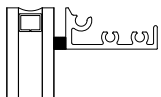

CASSETTE FRAME GLAZING - Inside Corner cont.

CASSETTE SSG GLAZING

Note: Use high grade structural silicone for SSG glass attachment to cassette frames. Follow manufactures' recommendations for application...environmental conditions, curing time and handling.

- STEP 1: Fill void between cassette frame and glass with silicone.
- STEP 2: Tool silicone around perimeter of frame.
- STEP 3: Prior to installing setting block chair P4217 install correct number of center anchors P4200 as shown in Fig. 76.1.
- STEP 4: Install setting block chair P4217 and setting block P1912S at quarter points.
- STEP 5: Move unit making sure not to disturb glass / cassette frame and let cure per manufactures' recommendations.

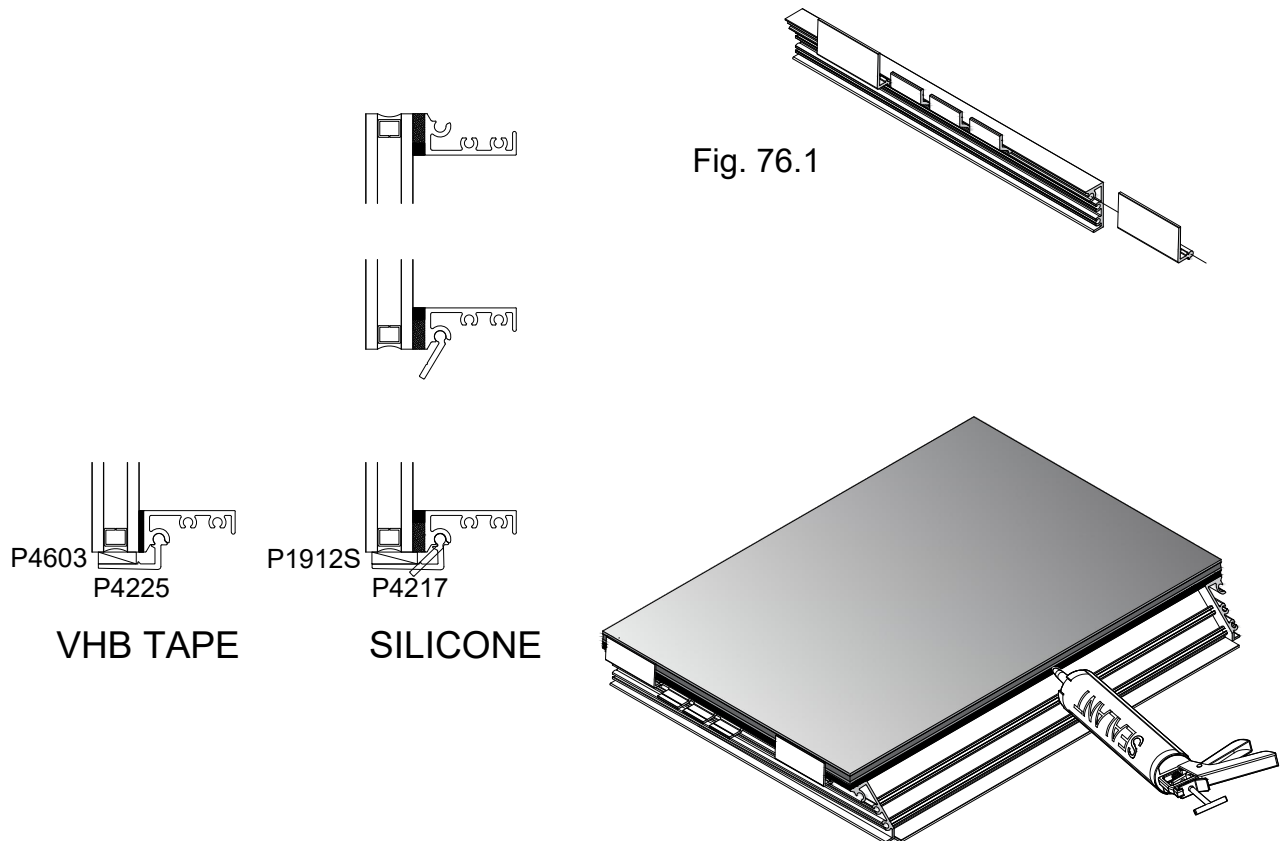

CASSETTE FRAME INSTALLATION - Inside Corner

- STEP 1: Placing a 3/4" spacer block on top of the lower unit will assist in setting up proper Cassette position. Refer to Fig. 77.1
- STEP 2: Place Cassette frame inside corner jamb in position at inside corner insert. Refer to Fig. 77.2.
- STEP 3: Rotate cassette frame towards back member framing to align with spacer gaskets. Refer to Fig. 77.3.
- STEP 4: Slide cassette frame towards inside corner into receiver until interior cassette frame surface is flush with back back member interior surface. Refer to Fig. 77.4
- STEP 5: Attach head anchor clips P4200 at 12" o/c and no more 2" from each end. Attaching the head anchor first will support the cassette frame dead load. Refer to Fig. 77.5.
- STEP 6: Continue anchoring anchor clips P4200 at sill and jamb.

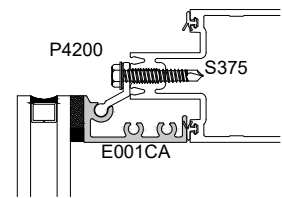
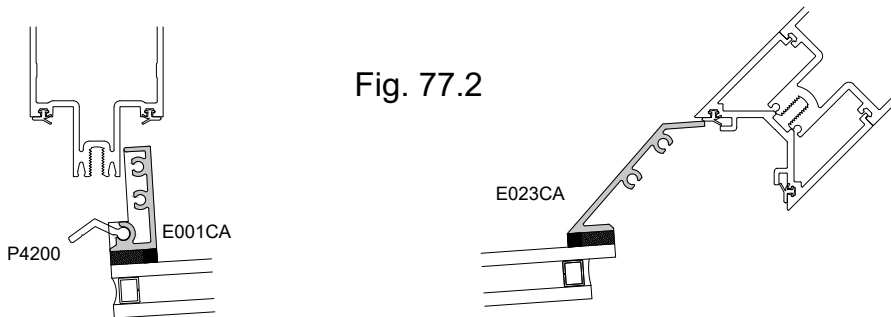
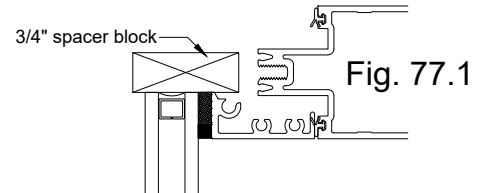
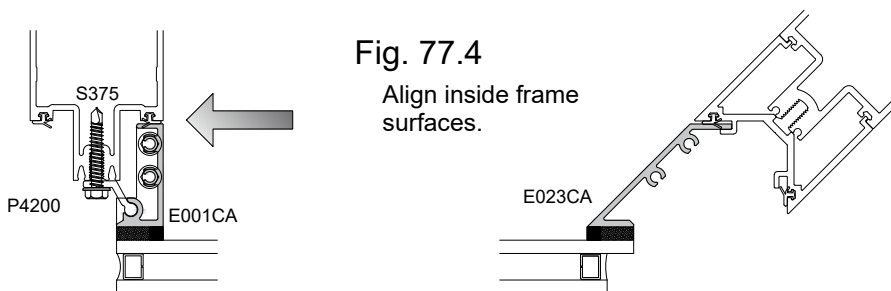
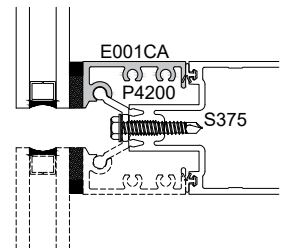
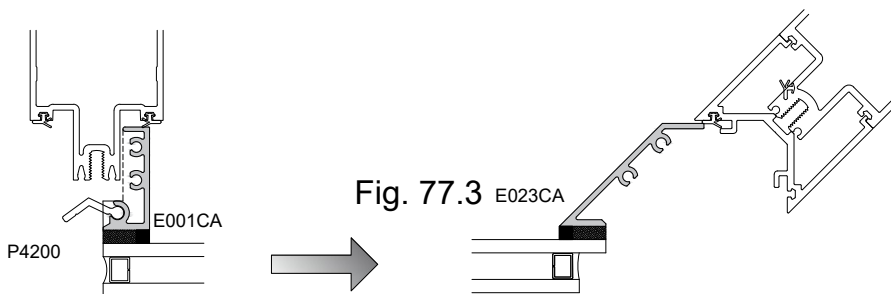

Fig. 77.5



CASSETTE FRAME INSTALLATION - Typical Framing

TYPICAL CASSETTE FRAME INSTALLATION

- Step 1: Select Cassette frame to be installed and install determined head anchor clips P4200 or P4202. (P4200 head anchor used at final top unit)
- Step 2: Set Cassette frame on sill dead load clip P4222 as shown at Fig. 78.1.
- Step 3: Roll Cassette frame towards back framing member.
- Step 4: Secure head anchor clip at center of Cassette frame. (note: cassette frame is now secure in opening)

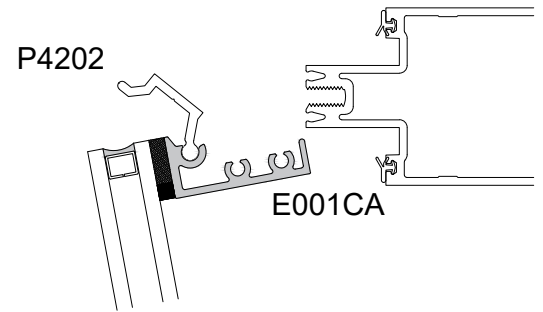
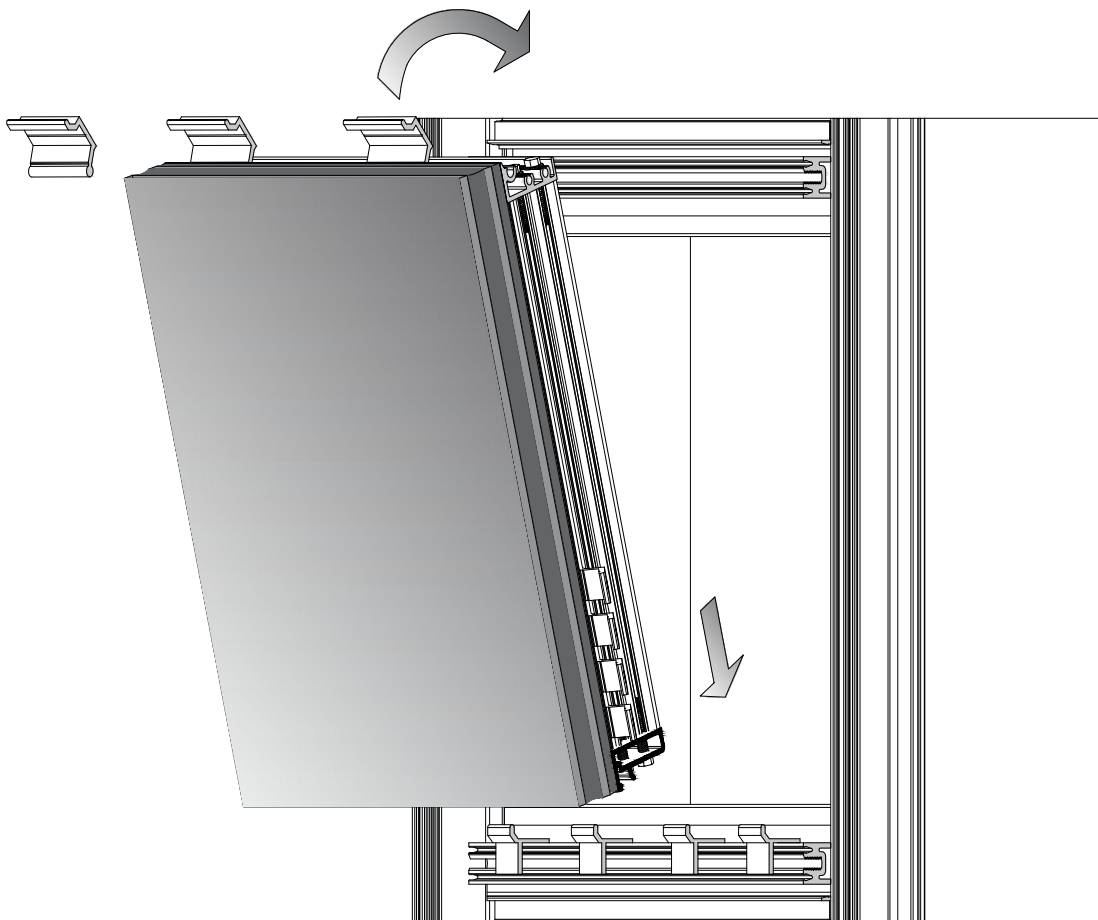
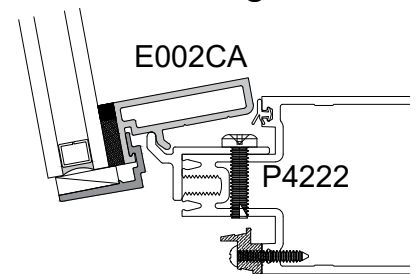

Fig. 78.1



CASSETTE FRAME INSTALLATION - Typical Framing

TYPICAL CASSETTE FRAME INSTALLATION - cont.

- Step 4: Secure head anchor clip at center of Cassette frame.
(note: cassette frame is now secure in opening)
- Step 5: Continue installing head anchor clips at 12" o/c and
and no more than 2" from ends of Cassette frame.
- Step 6: Slide Cassette jamb anchors P4200 into position starting
at the top of the jamb working towards sill of unit.

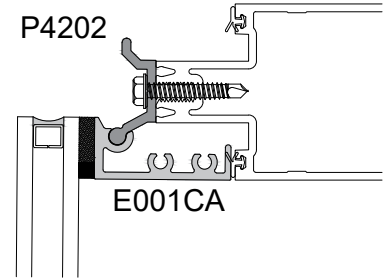
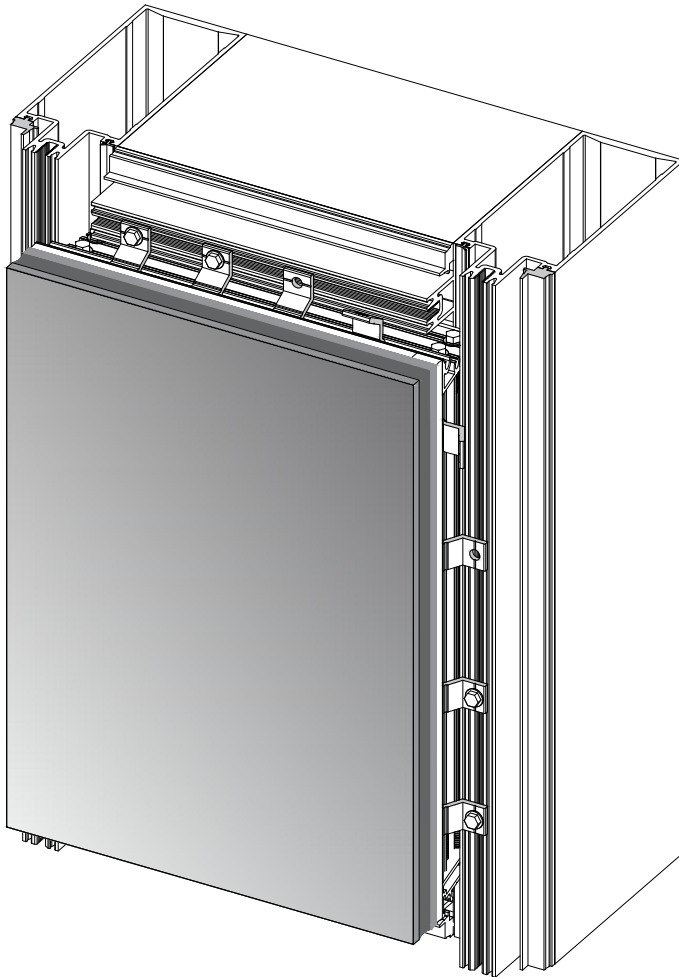
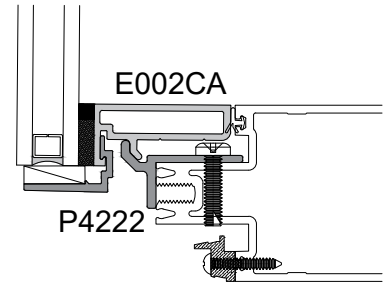
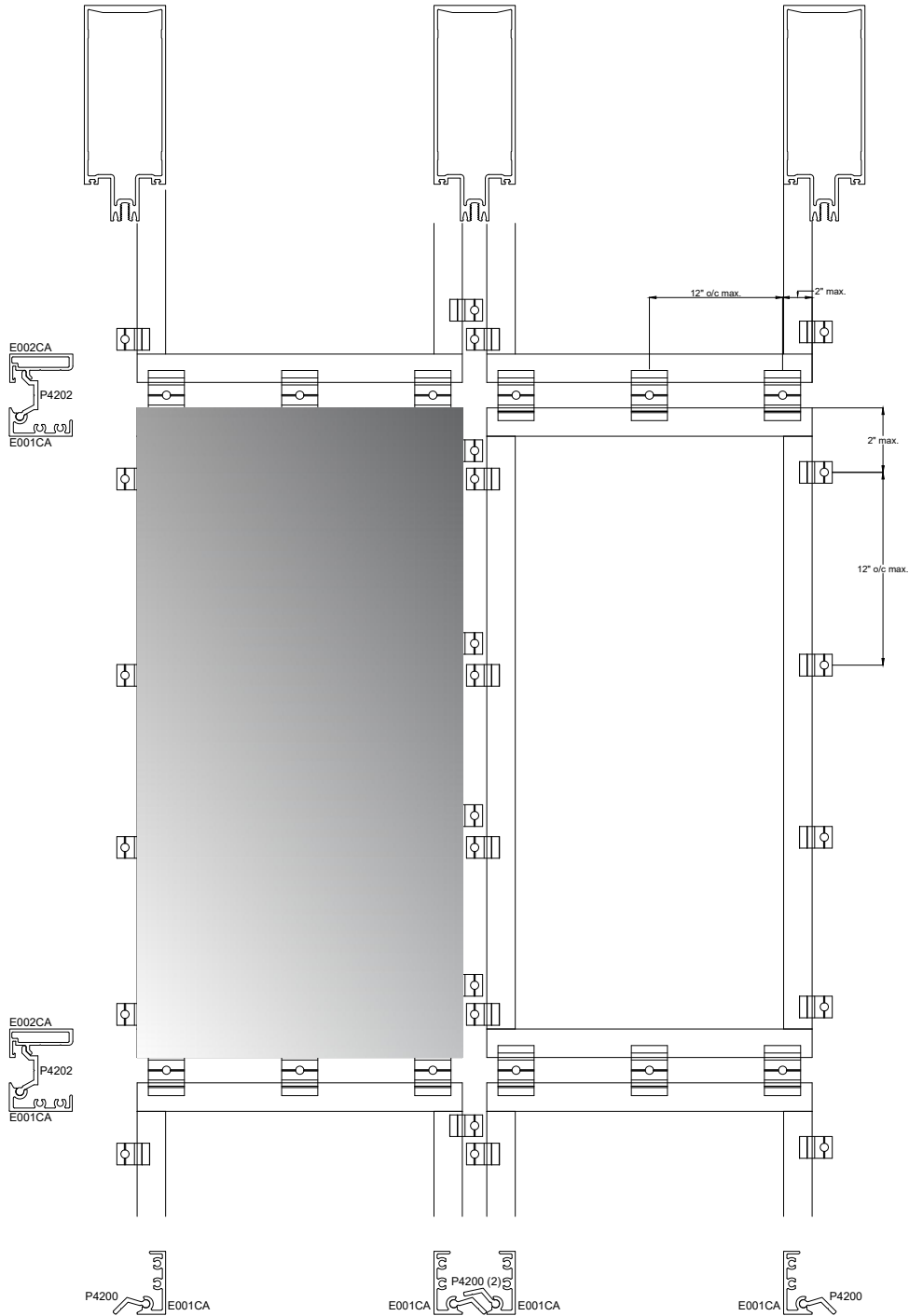

Fig. 79.1



CASSETTE FRAME INSTALLATION - Typical Anchor Pattern



CASSETTE FRAME PERIMETER CLOSURE TRIM INSTALLATION

OPTIONS ONE: Perimeter closure trim is designed for continual runs vertically and coped between curtain wall stems horizontally.

- STEP 1: Measure horizontally between curtain wall stems, subtract 1/8" and cut closure E004CA to length.
- STEP 2: Remove / cope back of E004CA closure trim to clear curtain wall stem as shown in Fig. 81.1.
- STEP 3: Install section of back rod behind front face as shown in Fig. 81.1.
- STEP 4: Using a rubber mallet and piece of wood blocking place E004CA trim over P4216 PVC separator and tap into place until trim snaps over P4216, Fig. 81.2.
- STEP 5: Repeat step 4 and install vertical closure trim.

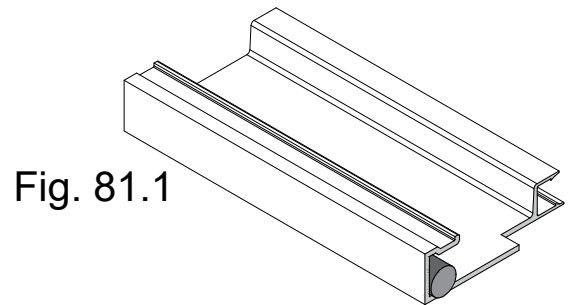
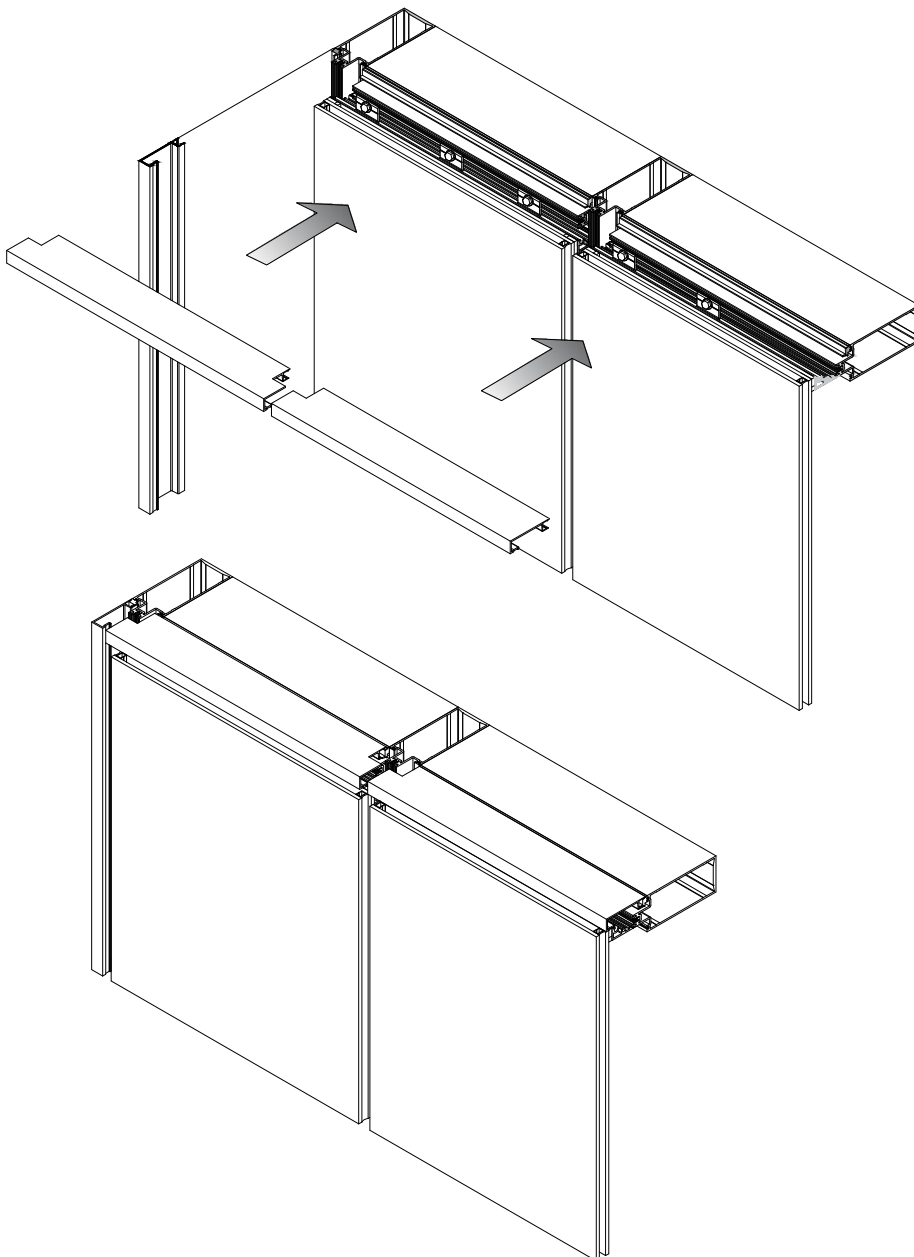

Fig. 81.1

Installed back rod prior to trim installation.

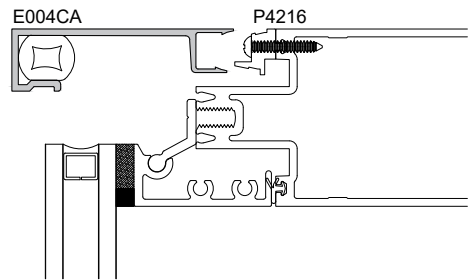
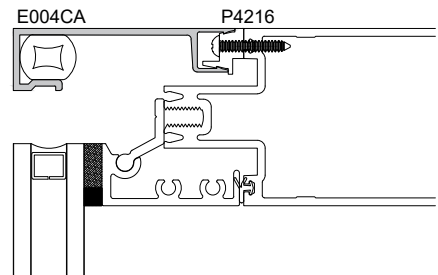

Fig. 81.2



CASSETTE FRAME PERIMETER CLOSURE TRIM INSTALLATION

OPTION TWO: Perimeter closure trim is designed for continual runs at VERTICAL and at HORIZONTAL.

- STEP 1: Verify copes are present at vertical stems, heads and sills of back members shown at Fig. 82.1 & Fig. 82.2 as dimensioned Fig. 82.3
- STEP 2: Install section of back rod behind front face as shown in Fig. 82.4. at horizontal and vertical splice.
- STEP 3: Using a rubber mallet and piece of wood blocking place E004CA trim over P4216 PVC separator and tap into place until trim snaps over P4216, Fig. 82.5.
- STEP 4: Repeat step 3 and install vertical closure trim.

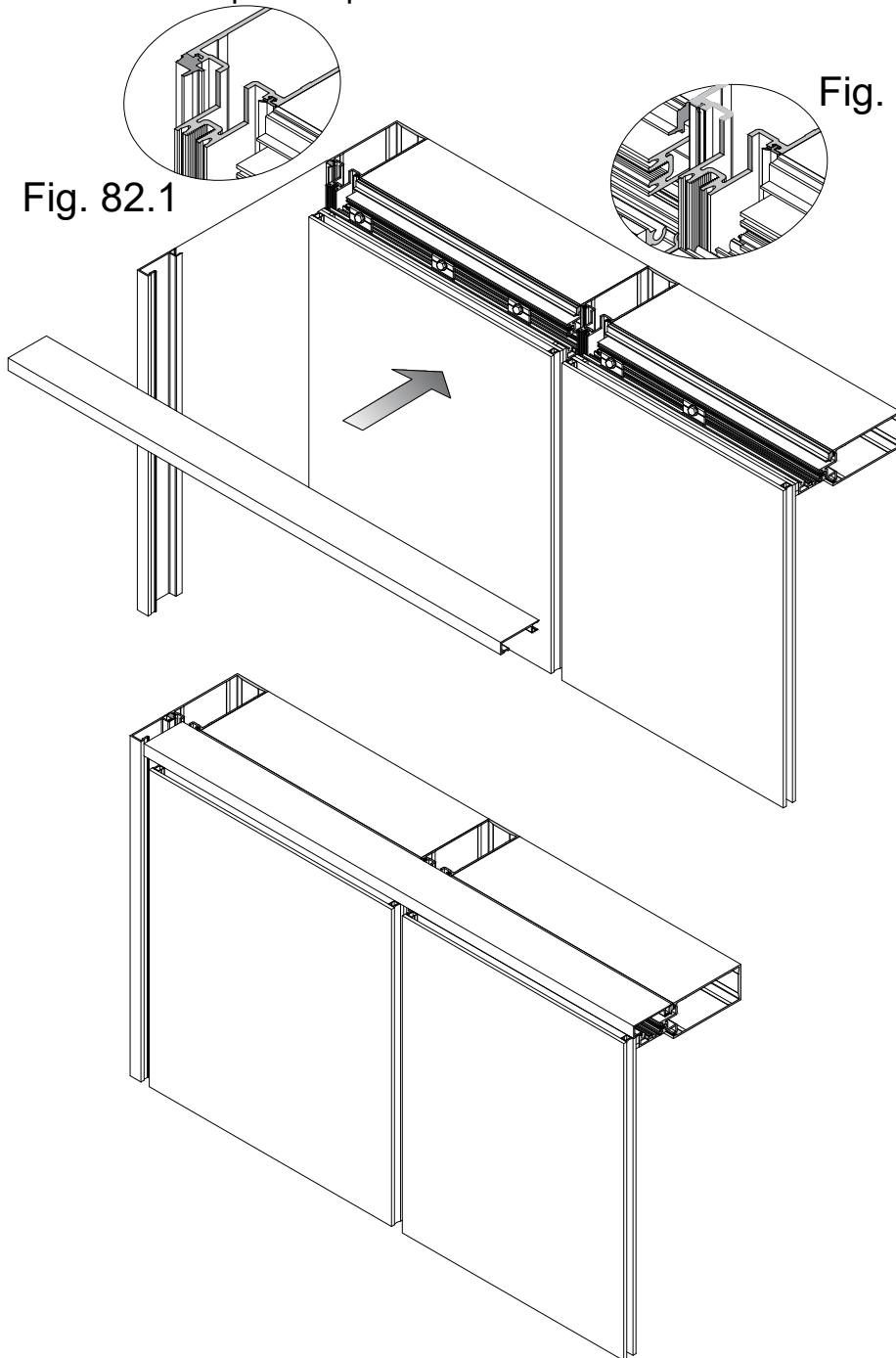

Fig. 82.1

Fig. 82.2

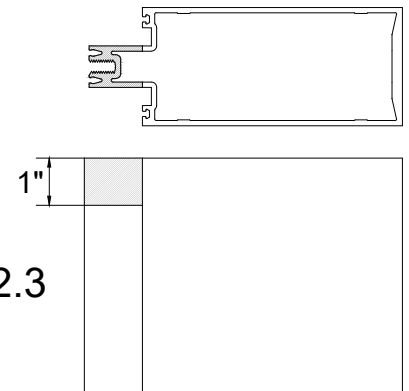

Fig. 82.3

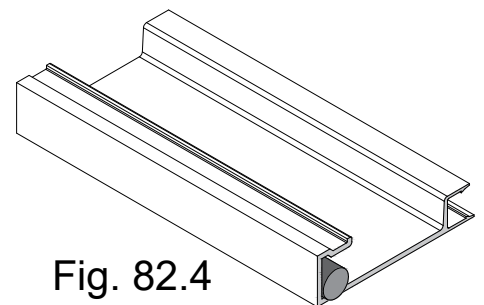

Fig. 82.4

Installed back rod prior to trim installation.

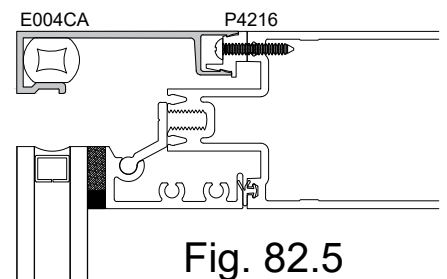

Fig. 82.5

CASSETTE FRAME PERIMETER SEALING

NOTE: Use silicone or silicone compatible sealant at perimeter seal and glass. Follow manufacturers' recommendations for application, environmental conditions and curing time.

STEP 1: Using isopropyl 70/30 mixture two towel wipe clean all surfaces to receive perimeter seal.

STEP 2: Install sealant at perimeter, between glass and closure trim to fill all voids. See Fig. 83.1.

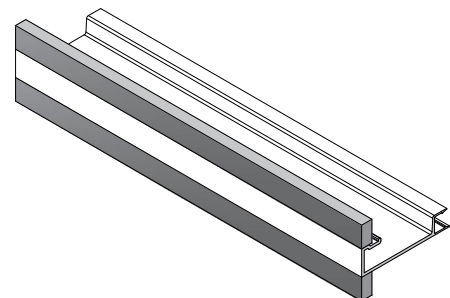
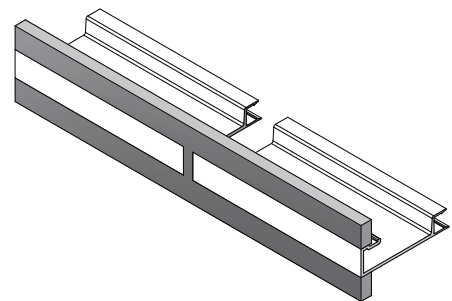
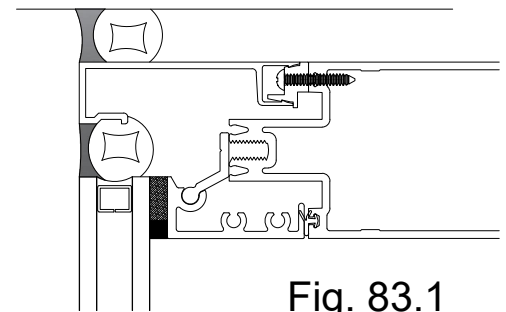
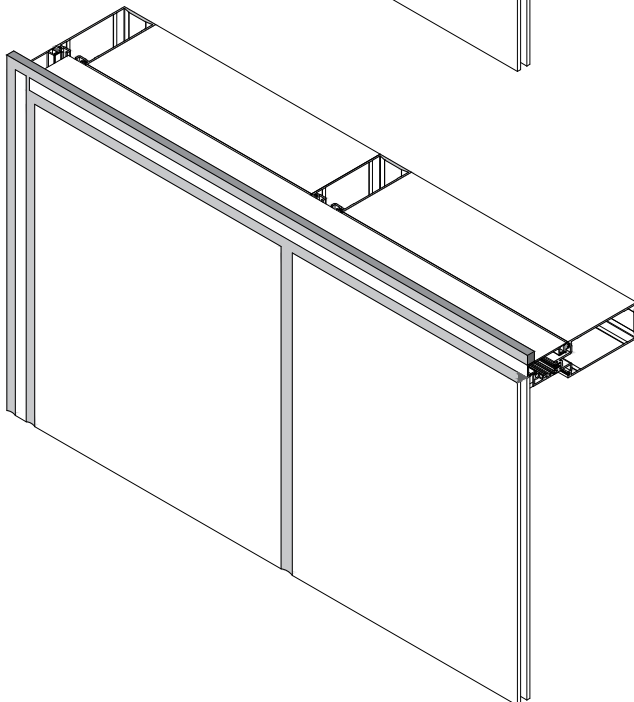
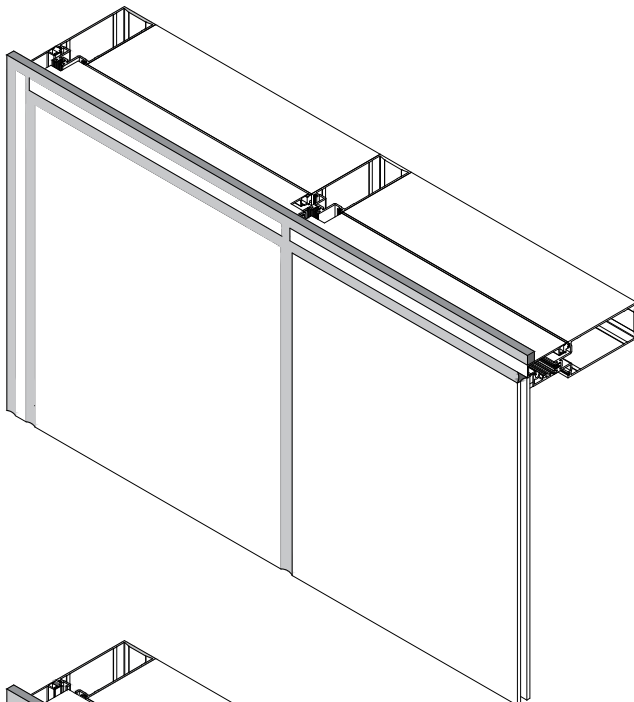
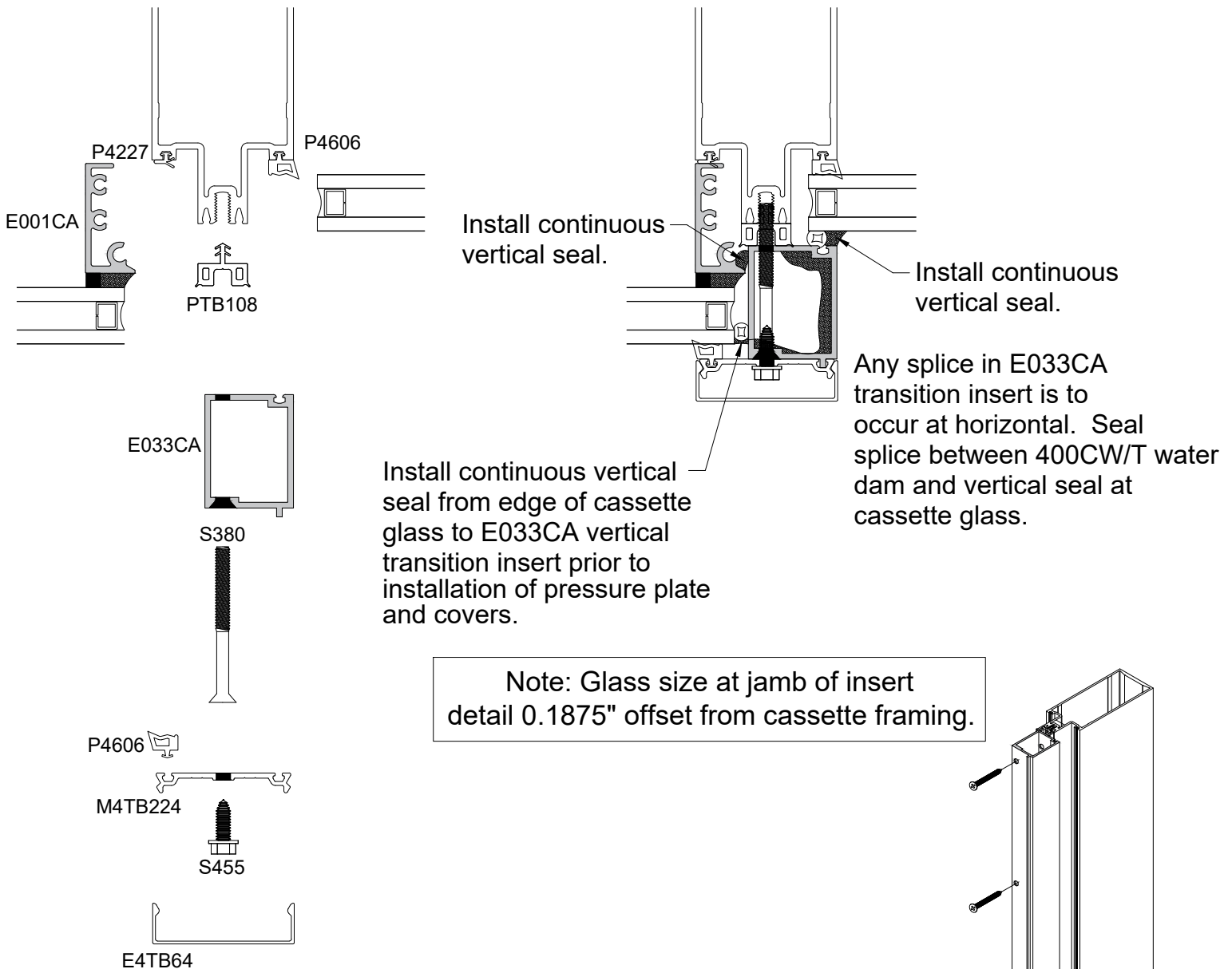

Fig. 83.1

CASSETTE FRAME - SSG Cassette to Captured PP Transition



- STEP 1: Complete installation of adjacent cassette framing.
- STEP 2: Install thermal separator PTB108 vertically and horizontally as required.
- STEP 3: Install continuous vertical seal between inside edge of cassette and thermal separator PTB108.
- STEP 4: Drill clearance holes in transition insert E033CA.
- STEP 5: Install adjacent glass and temp into place with P4634 temp clips.
- STEP 6: Install E033CA transition insert and secure with S380 fastener.
- STEP 7: Install continuous vertical seal between E033CA insert and cassette glass.
- STEP 8: Install continuous vertical seal between E033CA and curtain wall glass.
- STEP 9: All splices in E033CA are to be sealed and seal tied to 400CW/T adjacent water dams.
- STEP 10: Install pressure plates and covers per 400CW/T installation manual.

CASSETTE FRAME - Door Frame Trim Out

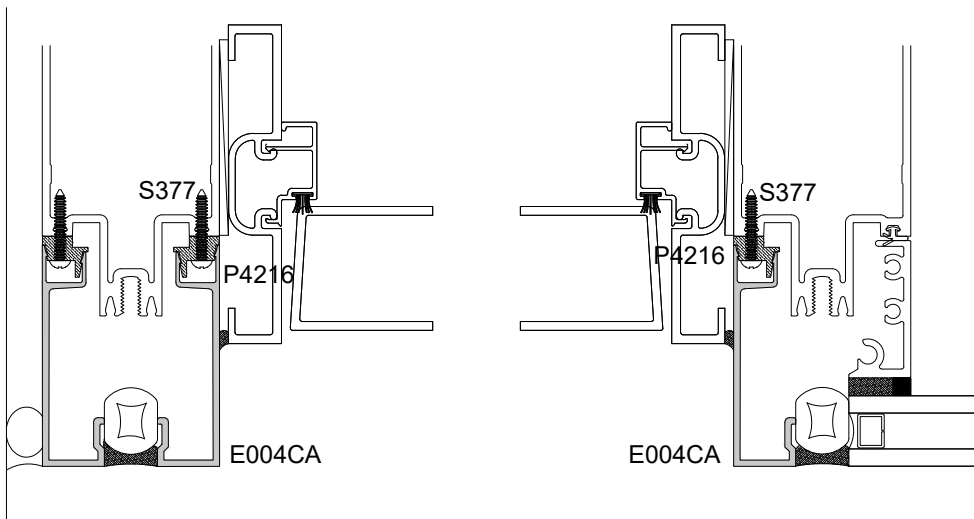
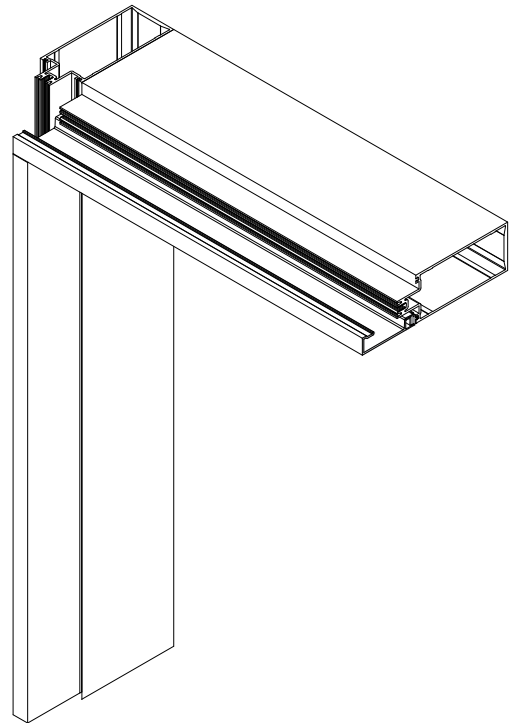
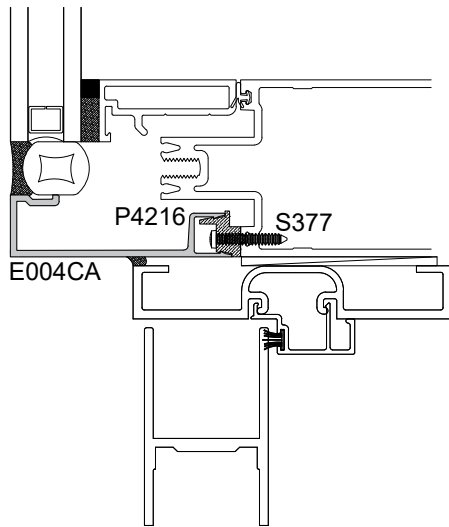

STEP 1: Using fastener S377, install PVC separator horizontally and vertically around door frame location.

STEP 2: Cut E004CA closure to length. NOTE: Horizontal trim to run across vertical closure.

STEP 3: Using a rubber mallet and piece of wood blocking tap E004CA over P4216 until closure snaps into place.

STEP 4: Install door framing and door stops per door installation manual.

CASSETTE FRAME INSTALLATION - InterStory Movement

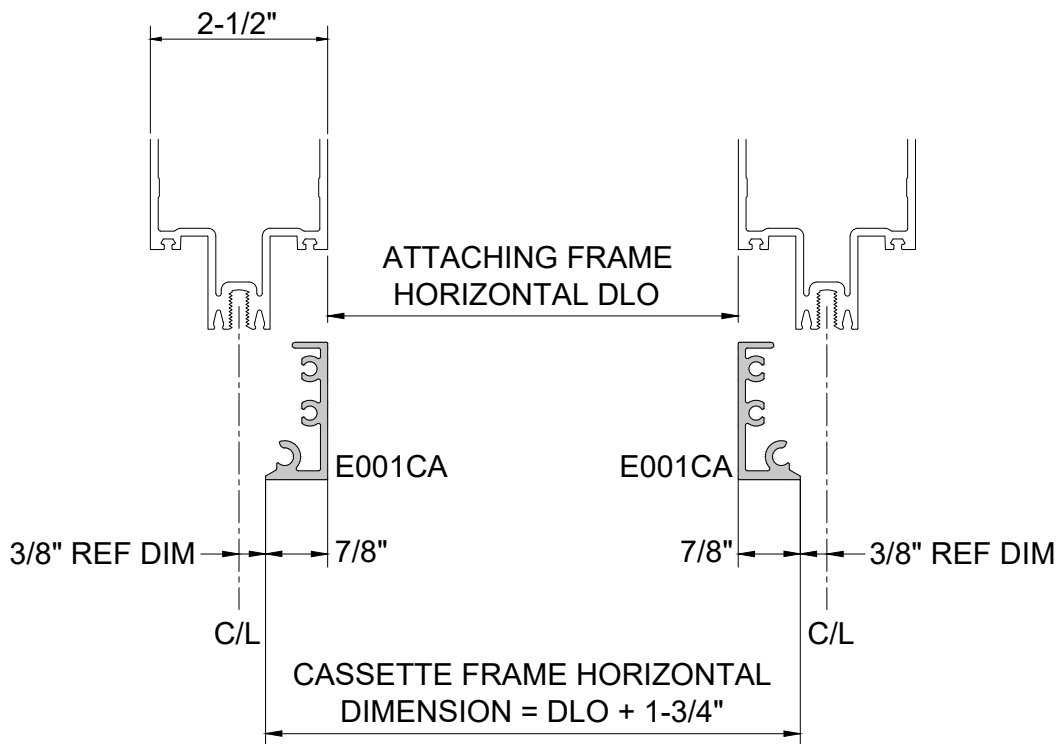
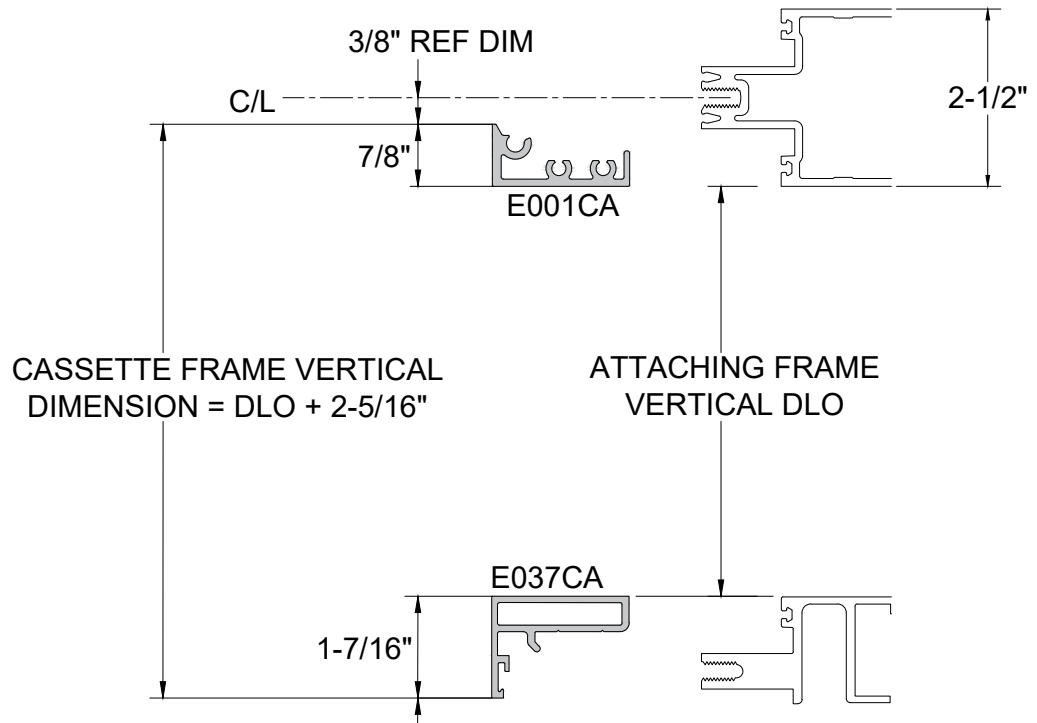

NOTE: Cassette frames sizes based on 400CW/T back members or 2-1/2" profile back members.

CASSETTE FRAME INSTALLATION - InterStory Movement

Cassette frame member Vertical / Horizontal cut size:

Vertical frame member cut size = DLO of attaching frame

Horizontal frame member cut size = DLO plus 2-5/16" of attaching frame

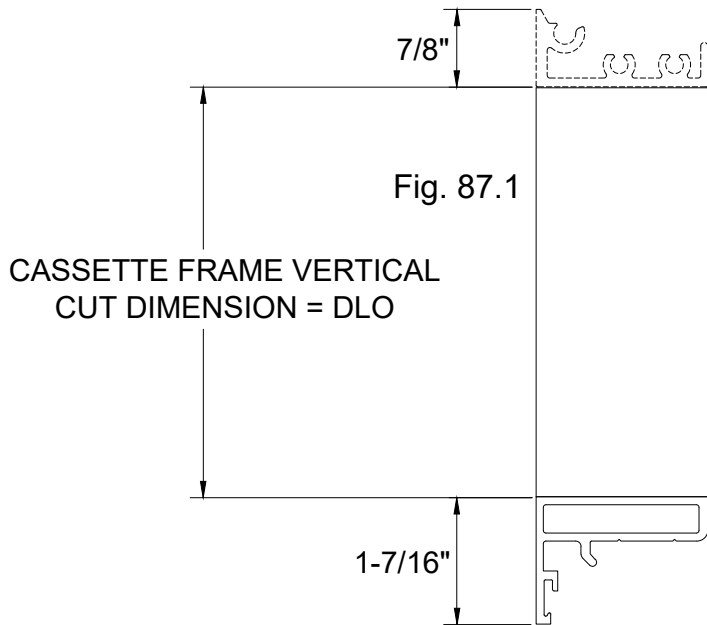

- STEP 1: Cut vertical (jamb) frame E001CA to calculated vertical cut size, Fig. 87.1.
- STEP 2: Cut horizontal head frame E001CA to calculated cut size mitering each end 11 degrees each end as shown at Fig. 87.2.
- STEP 3: Cut horizontal sill frame E002CA to calculated cut size mitering each end 11 degrees each end as shown at Fig. 87.2.

VERTICAL FRAME SIZE CALCULATOR

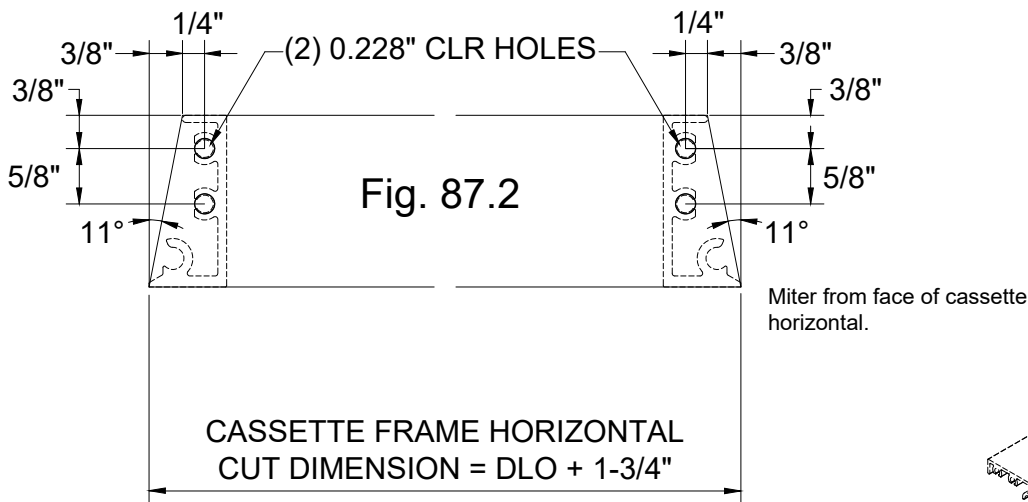

HORIZONTAL FRAME CUT and LAYOUT SECTION
 Standard Framing

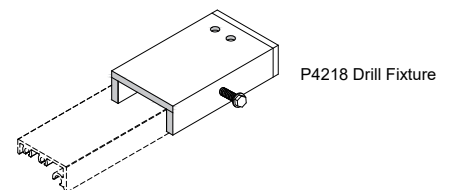

Assemble hole location as outlined below or drill fixture P4218 is available to assist with assemble hole location.

CASSETTE FRAME INSTALLATION - InterStory Movement

Setting Block Chair Cut Length: E040CA setting block chair at the inter-story movement (chicken head) runs continuous to receive PTB134 expanding gasket. Setting block chair cut length calculations below at Fig. 88.1

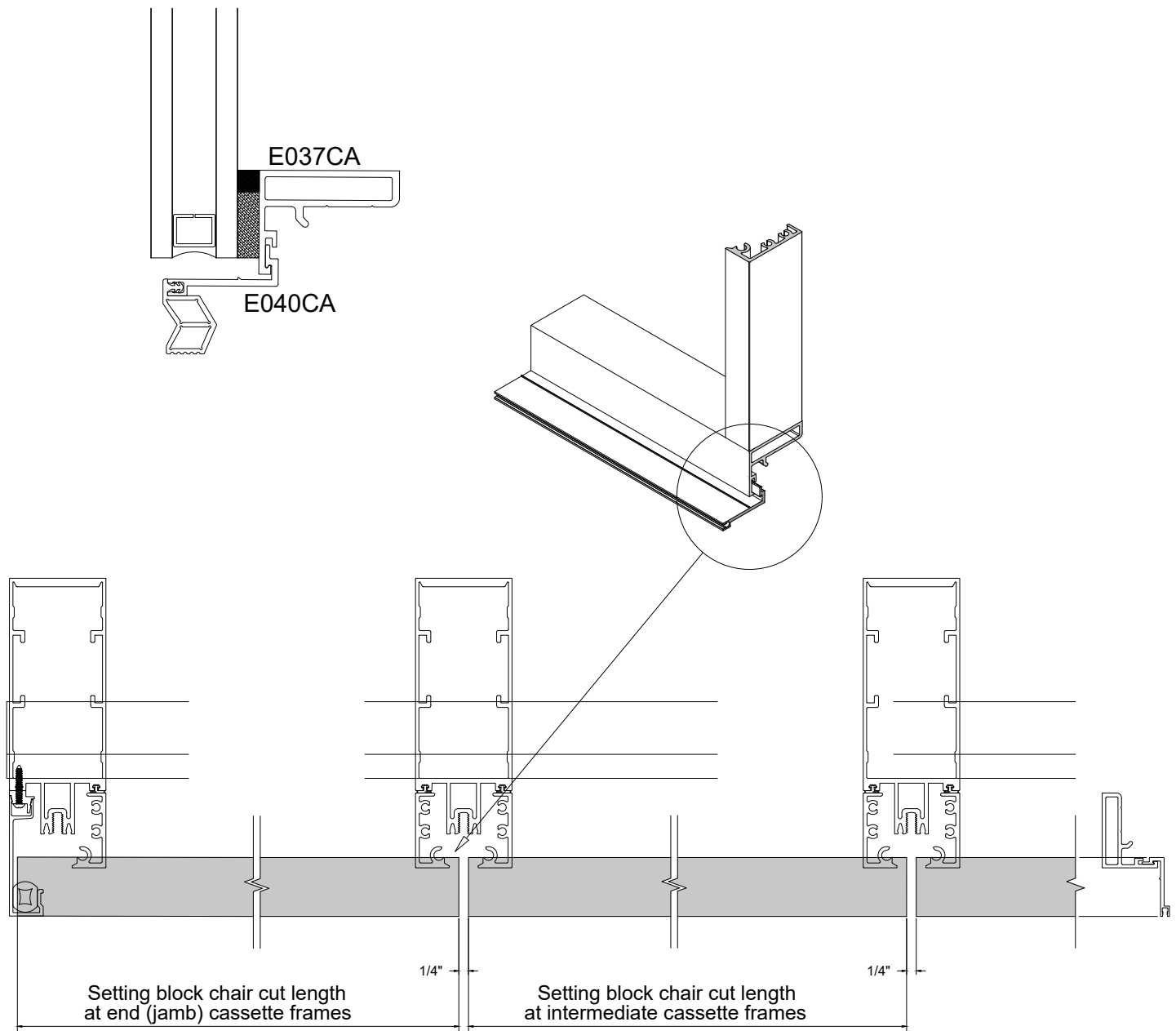

Cut length = Cassette Frame plus 1-7/8" Cut length = Cassette Frame plus 1/2"

Fig. 88.1

CASSETTE FRAME INSTALLATION - InterStory Movement

NOTE: Refer to 400T Curtain Wall installation manual for assembly and installation of 400T back member support framing.

Assemble back member support framing to inter-story (chicken head) location. Upper framing will be installed after lower Cassette and chicken head installation is completed.

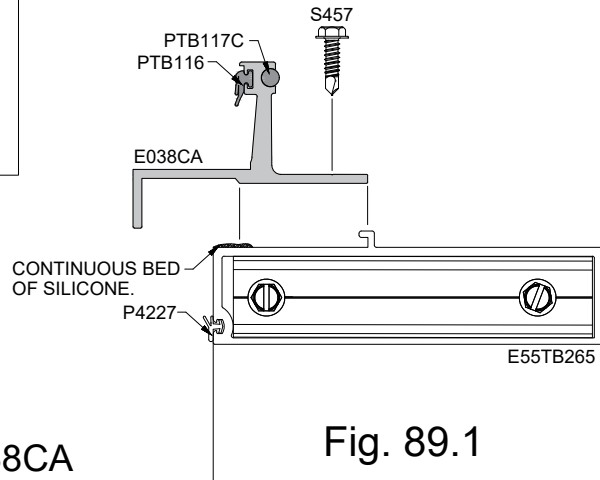

Fig. 89.1

- Step 1: Verify gasket P4227 is installed in back member framing.
- Step 2: Install PTB116 and PTB117C in E038CA chicken head frame member.
- Step 3: Install continuous bead of silicone on top front of frame E55265. See Fig. 89.1
- Step 4: Using fastener S457, secure chicken head frame E038CA to 400T back member E55TB265. See Fig 89.2

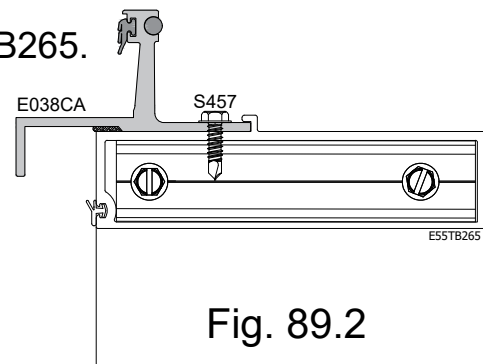
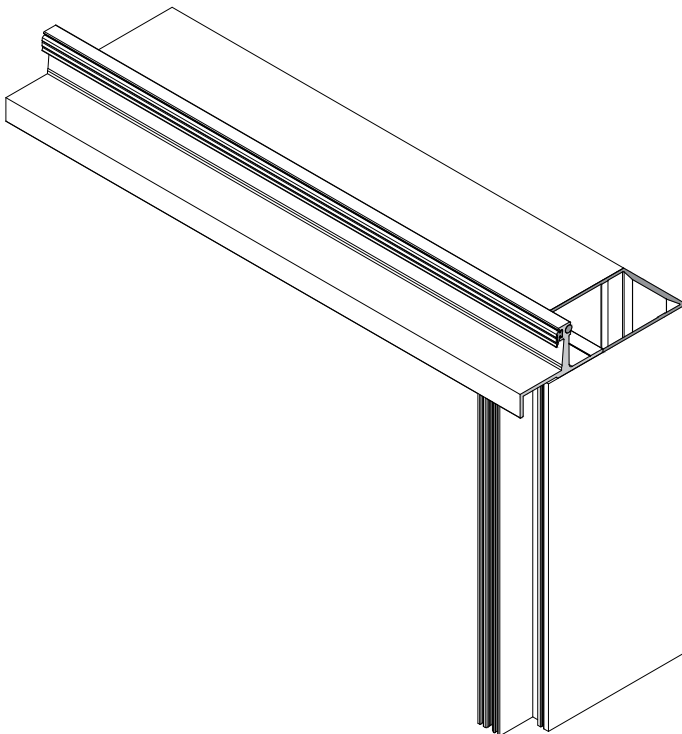
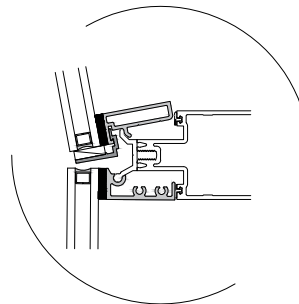
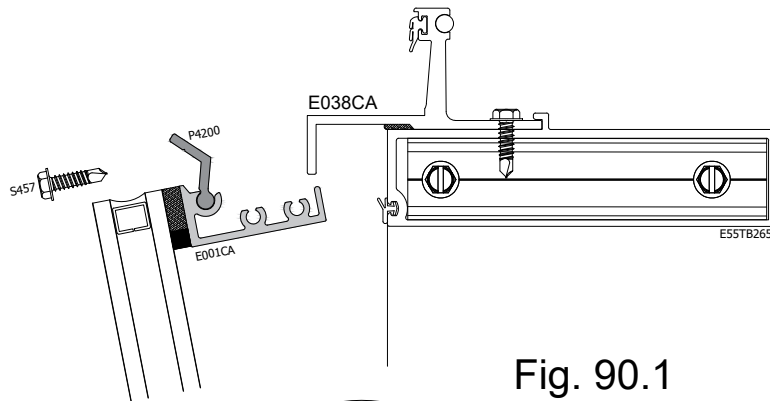

Fig. 89.2



CASSETTE FRAME INSTALLATION - InterStory Movement

Step 1: Install pre-glazed cassette frame to E038CA using P4200 pivot anchor (12" on center). Secure with S457 fasteners. See Fig. 90.1



Lower cassette sill detail for reference.

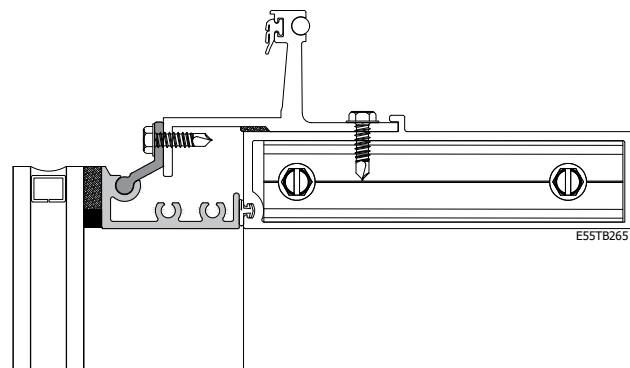

CASSETTE FRAME INSTALLATION - InterStory Movement

Step 1: Refer to Fig. 91.1 below for cut length calculator for chicken head extender E039CA.

Step 2: Install chicken head sill extender E039CA and secure with fastener S457 12" on center. Clean metal around fastener heads using Isopropyl two towel wipe and seal heads. See Fig. 91.2.

Step 3: Wipe clean metal at extender / base of chicken head using Isopropyl two towel wipe and install continuous of silicone to seal intersection. See Fig. 91.3.

Step 4: Clean metal at front bottom of chicken head extender and top of outer glass light with Isopropyl two towel wipe and install continuous silicone bead. Fig. 91.3

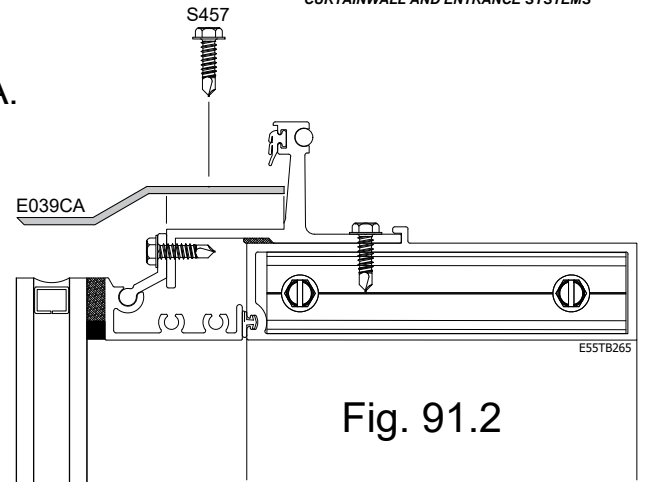

Fig. 91.2

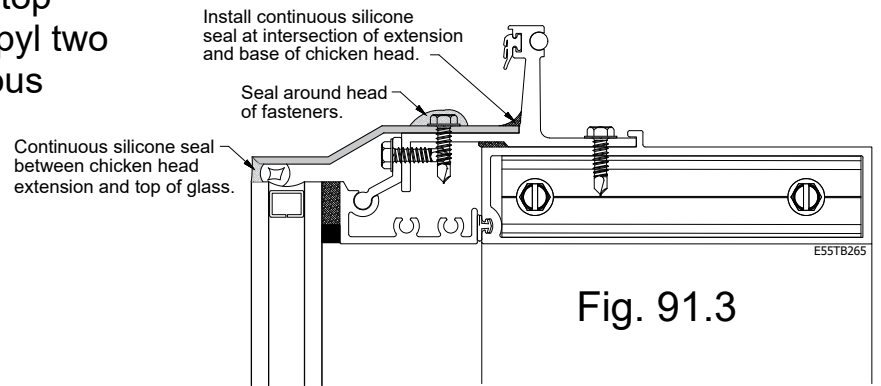

Fig. 91.3

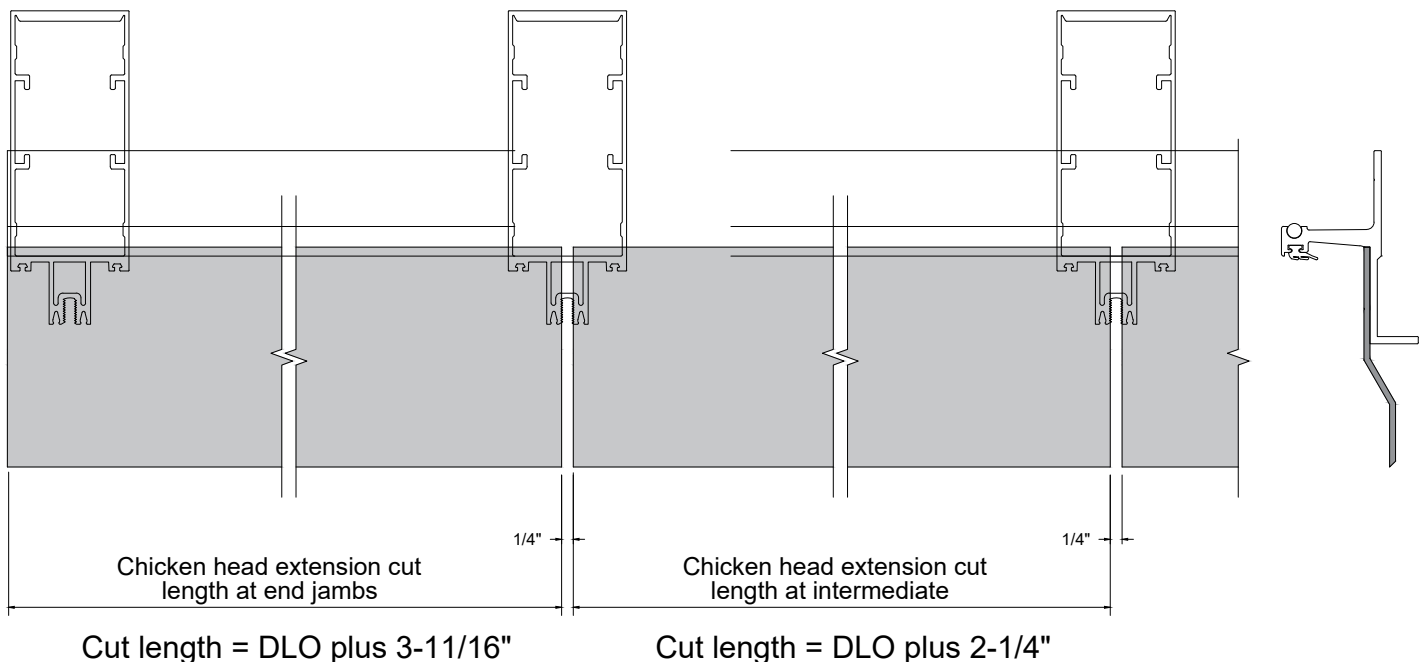

Fig. 91.1

CASSETTE FRAME INSTALLATION - InterStory Movement

- Step 1: Clean surface around splice area of chicken head and chicken head sill extension using isopropyl two towel wipe. See Fig. 92.1.
- Step 2: Install silicone bead on chicken head surface and extension where silicone sheet will be installed. See Fig. 92.3.
- Step 3: Press silicone sheet into position making sure sheet extends up to bottom of PTB116 sweep gasket.
- Step 4: Seal around perimeter of silicone sheet. See Fig. 92.3.
- Step 5: Apply silicone seal to back side of chicken head at splice around creating contact between back side of silicone sheet and around top of chicken head creating contact to back side of sweep gasket. See Fig. 92.2

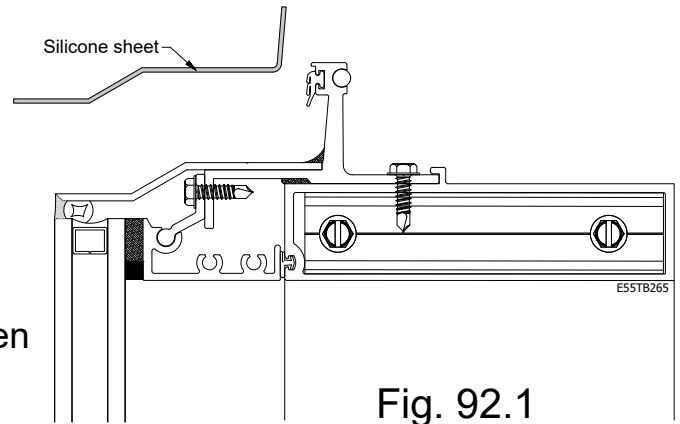

Fig. 92.1

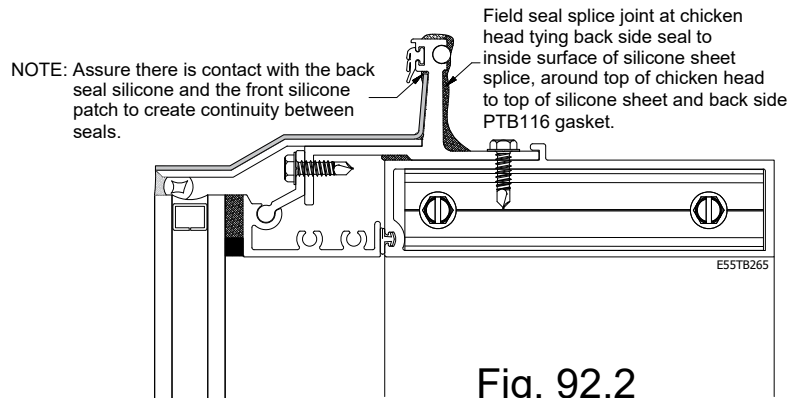

Fig. 92.2

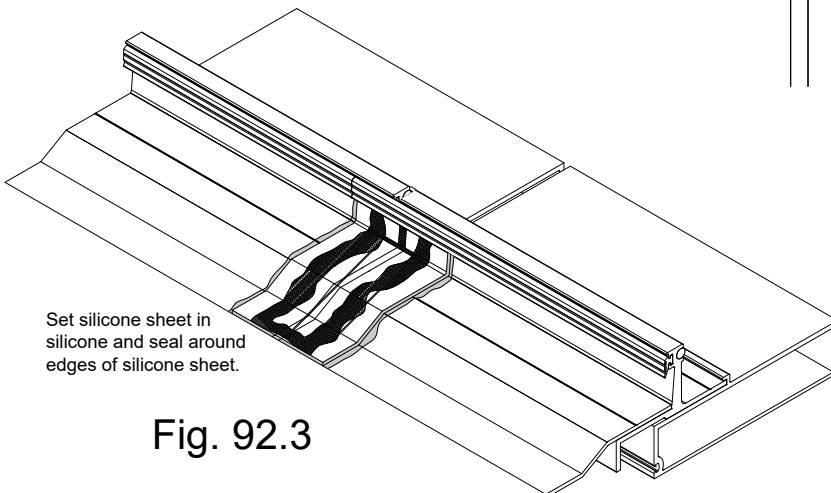

Fig. 92.3

CASSETTE FRAME INSTALLATION - InterStory Movement

Step 1: Install end caps to ends of chicken head and chicken head extension and seal end cap to chicken head and extension as shown in Fig. 93.1.

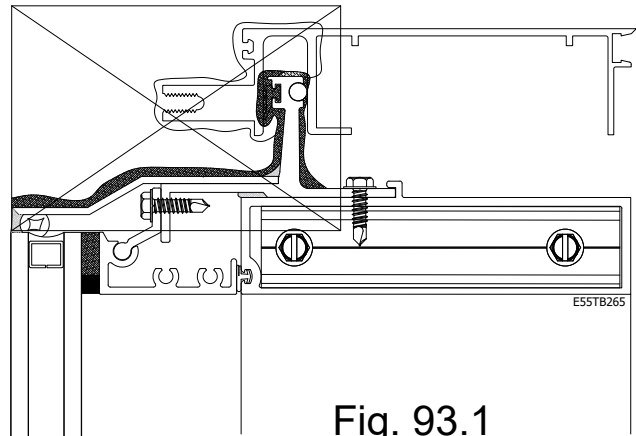
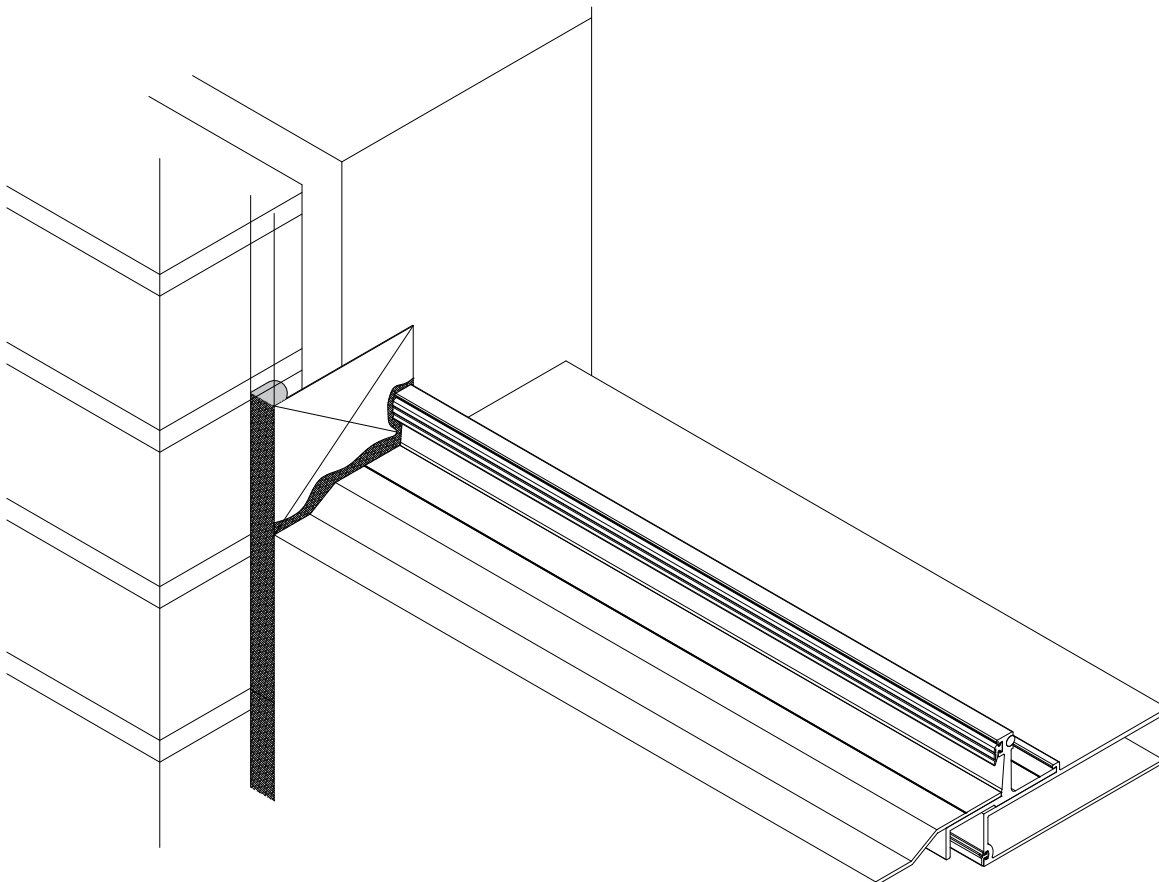

Fig. 93.1



CASSETTE FRAME INSTALLATION - InterStory Movement

NOTE: Refer to 400T Curtain Wall installation manual for assembly and installation of 400T back member support framing.

Assemble back member support framing to inter-story (chicken head) location. Upper framing will be installed after lower Cassette and chicken head installation is completed.

- Step 1: Install P4810 foam rod at chicken head splice, set in sealant to hold in place. See Fig. 94.1
- Step 2: Install next portion of assembled 400T back support member sliding sill cope over head of chicken head and secure back member framing maintaining gap required for movements. See Fig. 94.1
- Step 3: Once back support frame is installed and secured, install Cassette sill anchor P4222 12" on center and secure with fastener S292. See Fig. 94.2
- Step 4: Install pre-glazing Cassette frame, roll over P4222 anchor clip and secure at head and jambs. See Fig. 94.3.

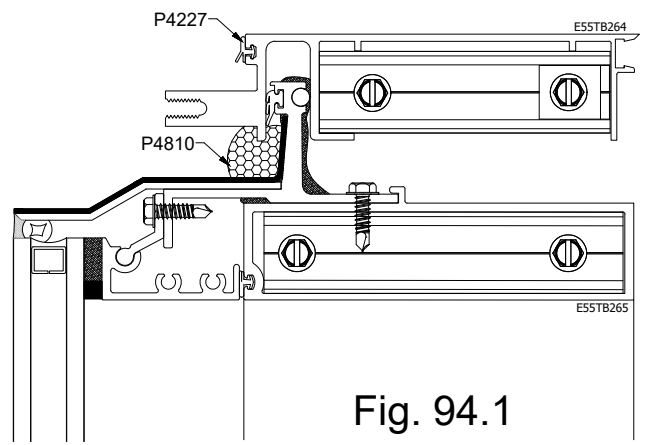

Fig. 94.1

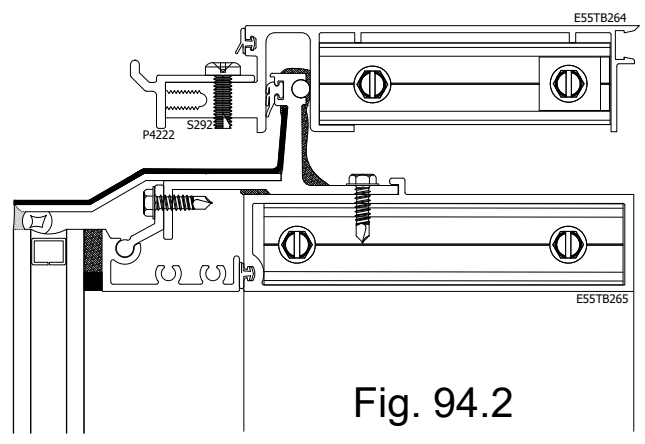

Fig. 94.2

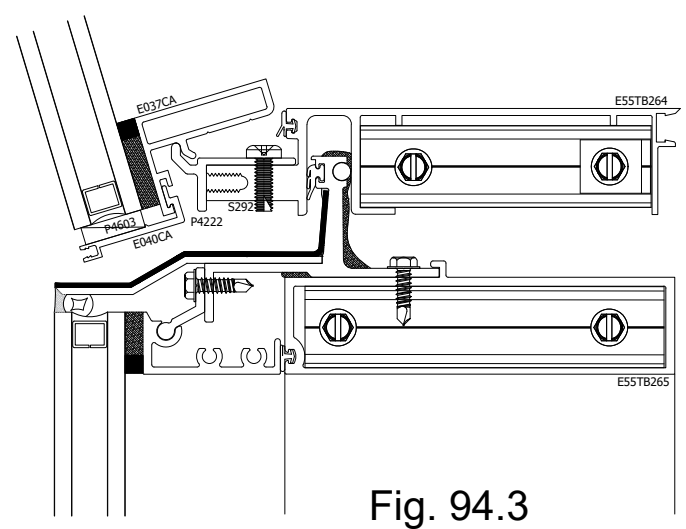

Fig. 94.3

CASSETTE FRAME INSTALLATION - InterStory Movement

- Step 1: Install expansion gasket PTB134 into race on setting block chair E040CA. See Fig. 95.1.
- Step 2: Install continuous silicone seal between expansion gasket PTB134 / setting block chair E042CA and edge of glass. See Fig. 95.2.
- Step 3: Silicone seal PTB134 gasket splices with silicone. See Fig. 95.3.

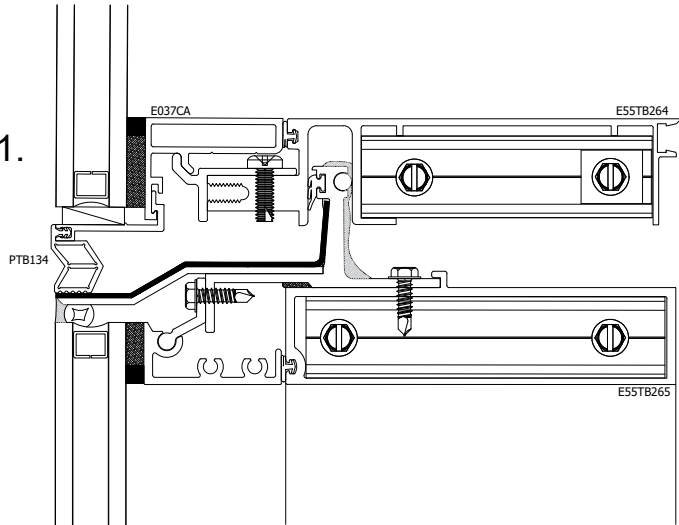

Fig. 95.1

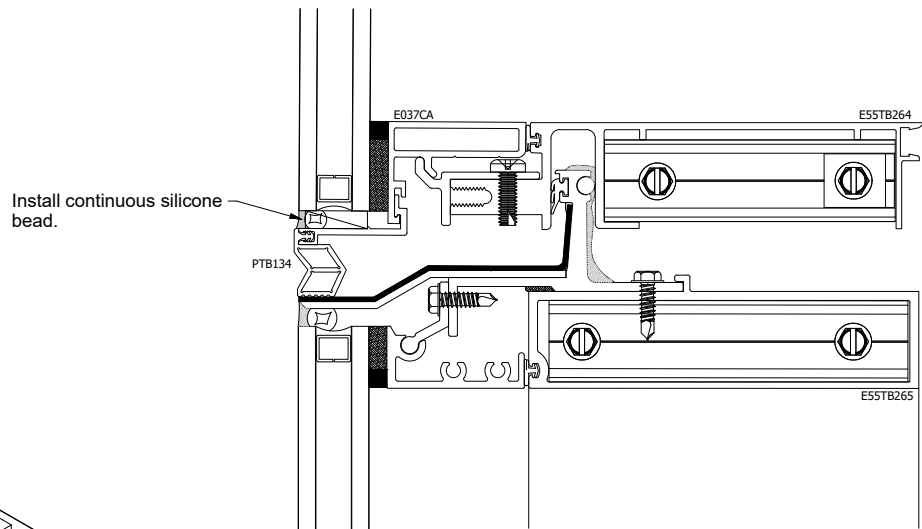

Fig. 95.1

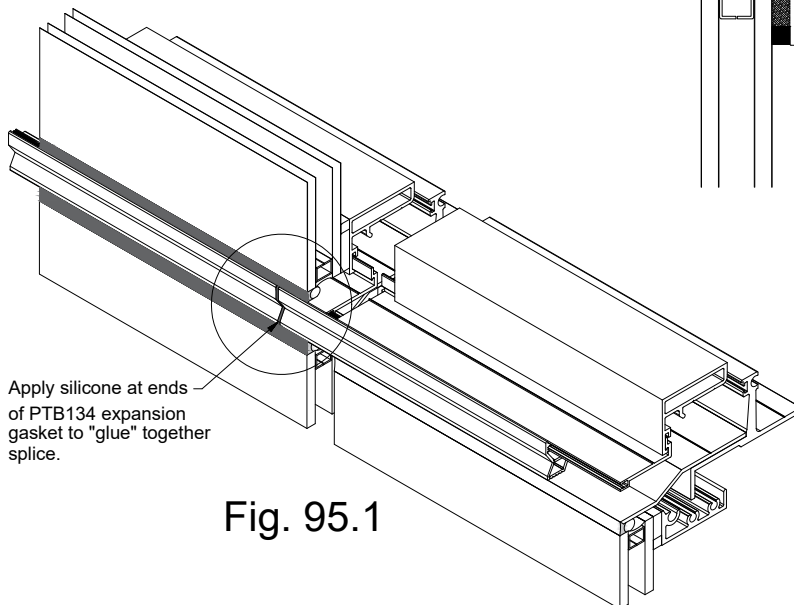

Fig. 95.1

CASSETTE FRAME INSTALLATION - InterStory Movement

NOTE: Perimeter closure E004CA to allow for horizontal expansion. Cut length lower vertical to stop at horizontal seal at top of glass lite, upper vertical to start at horizontal seal at bottom of glass. See Fig. 96.1

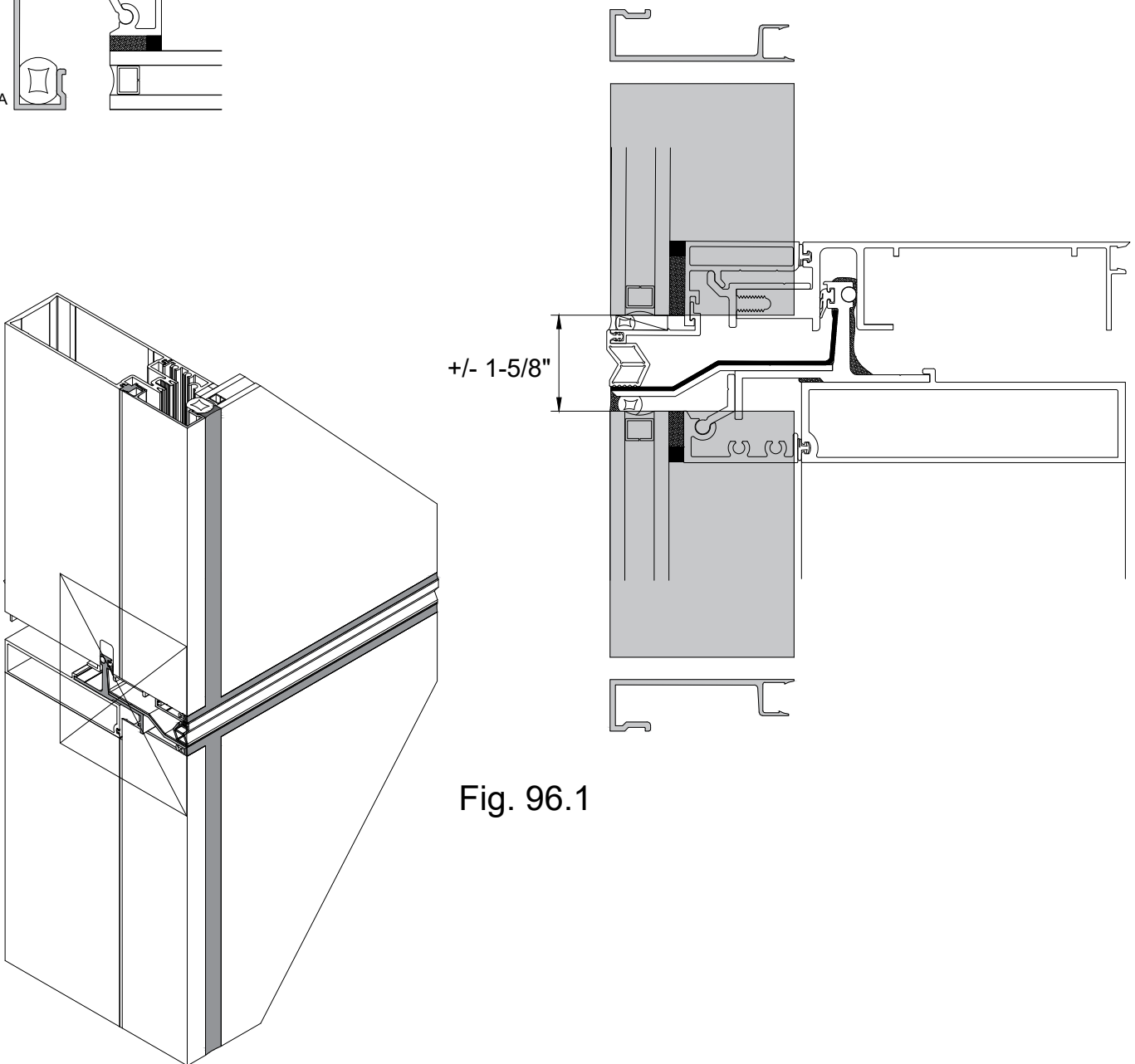
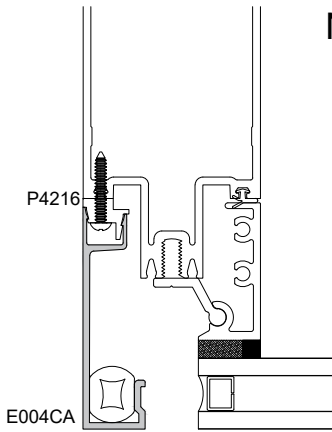
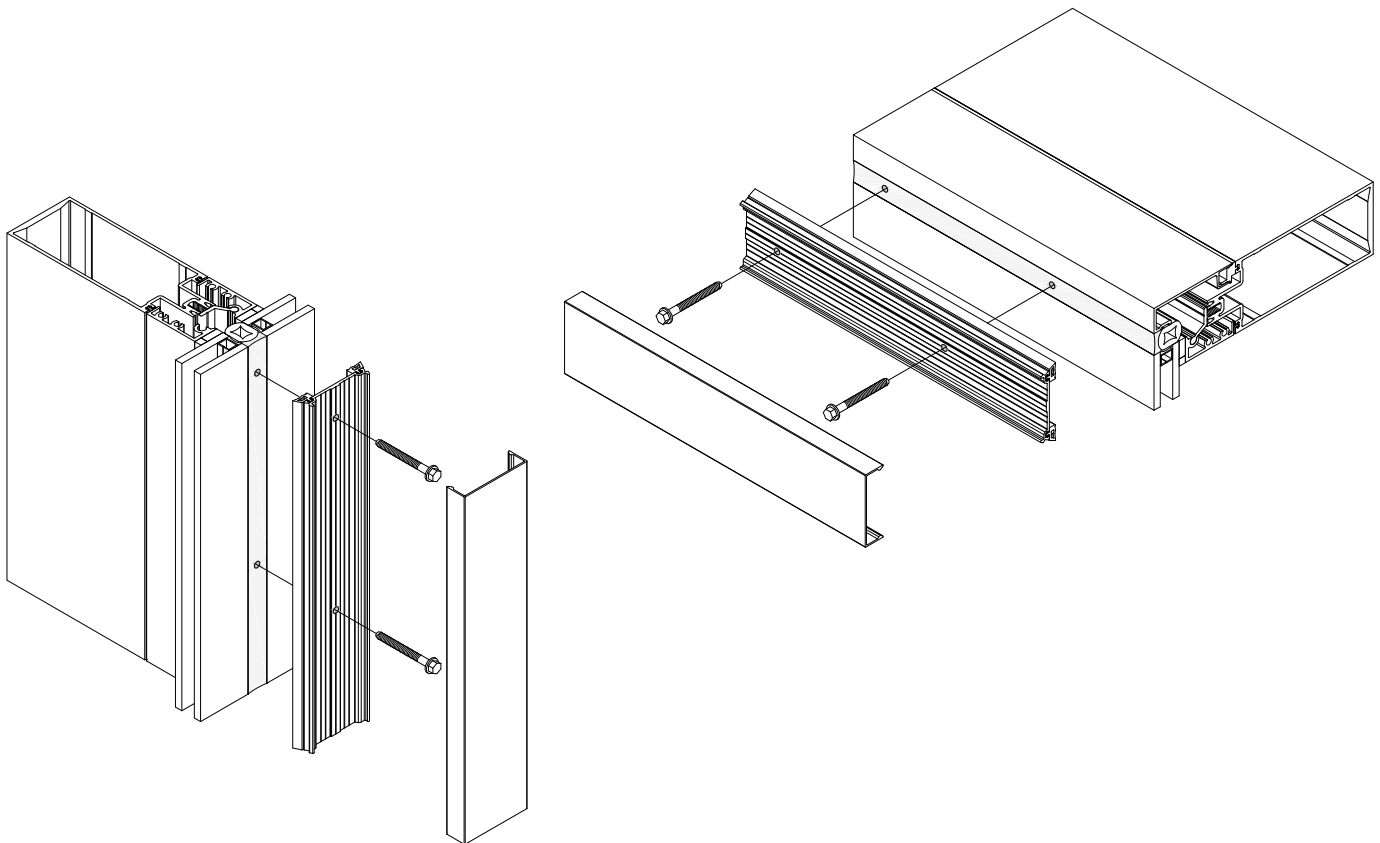
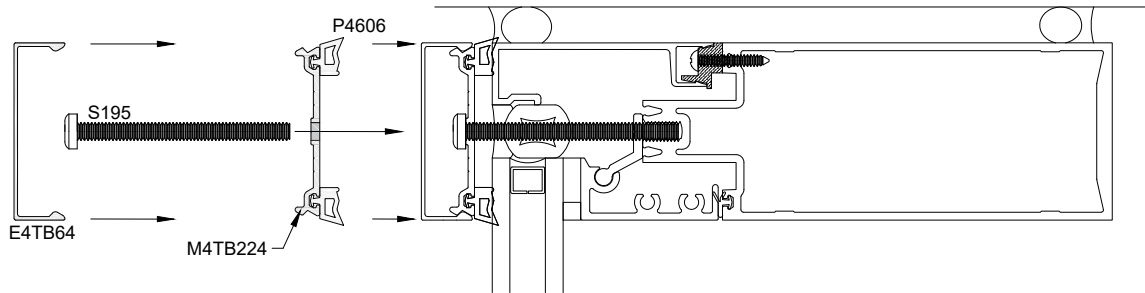

Fig. 96.1

CASSETTE FRAME - Exterior Accent Cover Installation



- STEP 1: Cut pressure plate M4TB224 to length...end holes to be no more than 2" from ends, 1/4" clearance holes may have to be drilled at ends.
- STEP 2: Hold M4TB224 in position and mark or drill holes in joint sealant.
- STEP 3: Fill drilled hole with sealant.
- STEP 4: Install gasket P4606 onto M4TB224.
- STEP 5: Hold M4TB224 in position and secure with S195 fastener..use all holes in M4TB224 pressure plate.
- STEP 6: Use blocking and tap cover (E4TB64) into position.