

TUBELITE®

DEPENDABLE

LEADERS IN ECO-EFFICIENT STOREFRONT,
CURTAINWALL AND ENTRANCE SYSTEMS

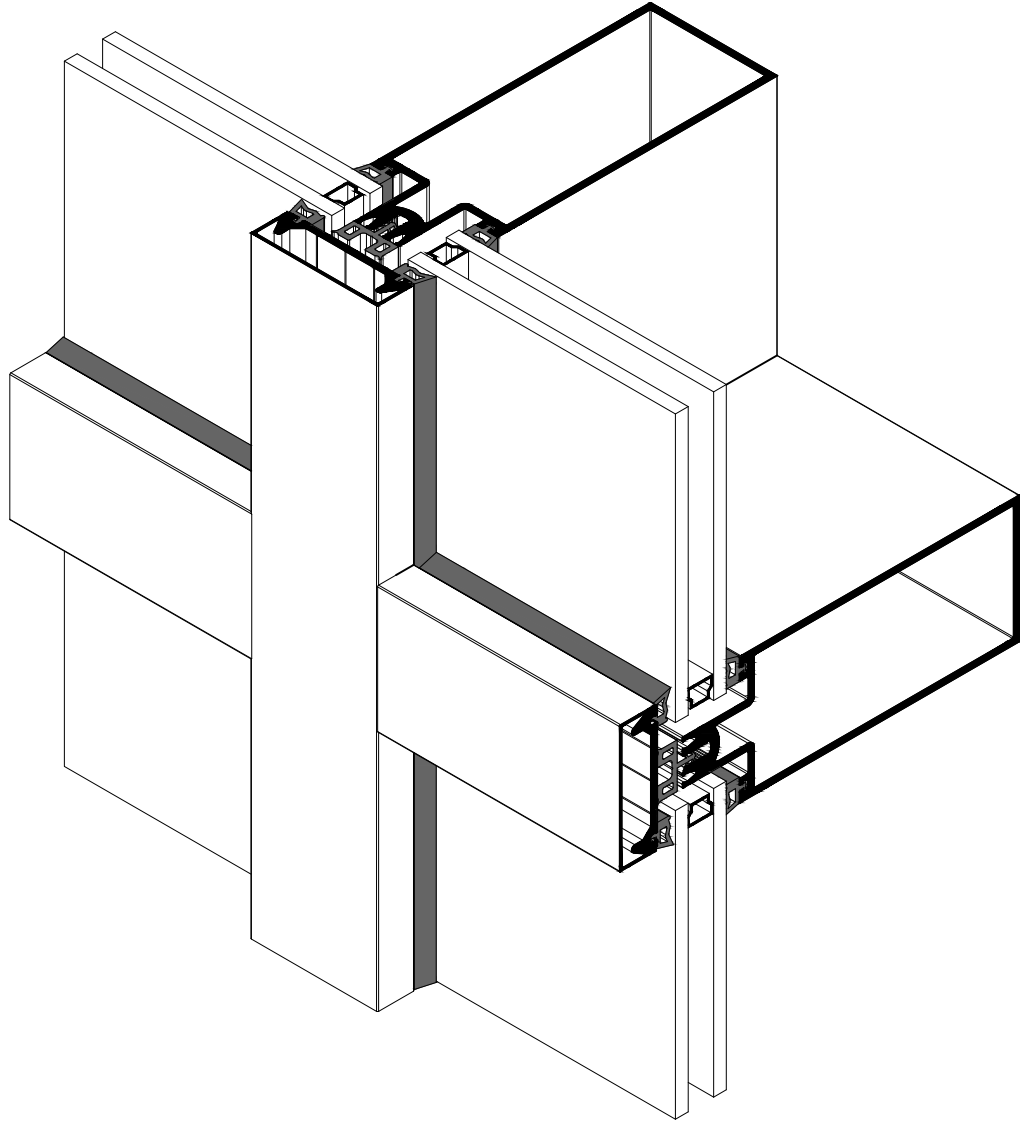

400T SERIES BLAST RESISTANT CURTAIN WALL INSTALLATION INSTRUCTIONS

3056 Walker Ridge Dr. NW, Suite G • Walker, MI 49544 • 800-866-2227

BLANK

TABLE OF CONTENTS

GENERAL CONSTRUCTION NOTES	4-5
QUICK REFERENCE CHECKLIST	5
PARTS LIST	6-11
ELEVATION TYPES and DETAILS	12-17
FRAME FABRICATION	
Step 1 Determine Frame Size	18
Step 2 Cut Material to Size	19-20
Step 3 Drill Verticals for Shear Blocks	21
Step 4 Drill Horizontals for Shear Block Attachment	22
Step 5 Drill Weep Holes in Horizontal Pressure Plates	23
Step 6 Fabricate Weep Slots in Face Covers	24
Step 7 Notch Head & Sill for Anchor Clearance	24
Step 8 Fabricate Perimeter Anchor Clip	25-26
Step 9 Install Steel Reinforcement as Required	27
Step 10 Fasten Shear Blocks to Vertical	28
Step 11 Install Head and Sill 'F' and 'T' Anchors	29
FRAME INSTALLATION	
Step 12 Installing Vertical Mullions	30
Step 13 Attach Horizontals to Shear Blocks and Anchor Clips	31-33
Step 14 Install Water Dams	34
Step 15 Apply Perimeter Seal to Installation	35
GLAZING	
Step 16 Glazing Preparation	36
Step 17 Installing Gaskets and Spacers	36-37
Step 18 Installing Glass	37-39
Step 19 Install Pressure Plates and Face Covers	40-44
ENTRANCE FRAMING	45-46
REGLAZING	47

GENERAL CONSTRUCTION NOTES

GENERAL CONSTRUCTION NOTES

1. These instructions cover typical product application, fabrication, installation and standard conditions and are general in nature. They provide useful guidelines, but the final shop drawings may include additional details specific to the project. Any conflict or discrepancies must be clarified prior to execution.
2. Materials stored at the job site must be kept in a safe place protected from possible damage by other trades. Stack with adequate separation so materials will not rub together and store off the ground. Cardboard or paper wrapped materials must be kept dry. Check arriving materials for quantity and keep a record of where various materials are stored.
3. All field welding must be done in accordance with AISC guidelines. All aluminum and glass should be shielded from field welding to avoid damage from weld splatter. Results will be unsightly and may be structurally unsound. Advise general contractor and other trades accordingly.
4. Coordinate protection of installed work with general contractor and/or other trades.
5. Coordinate sequence of other trades which affect framing installation with the general contractor (e.g. fire proofing, back up walls, partitions, ceilings, mechanical ducts, HVAC, etc.).
6. General contractor should furnish and guarantee bench marks, offset lines and opening dimensions. These items should be checked for accuracy before proceeding with erection. Make certain that all adjacent substrate construction is in accordance with the contract documents and/or approved shop drawings. If not, notify the general contractor in writing before proceeding with installation because this could constitute acceptance of adjacent substrate construction by others.
7. Isolate all aluminum to be placed directly in contact with masonry or other incompatible materials with a heavy coat of zinc chromate or bituminous paint. Fasteners attaching framing to building structure are typically not provided by Tubelite.
8. Sealant selection is the responsibility of the erector, installer and/or glazing contractor and must be approved by the sealant manufacturer with regard to application and compatibility for its intended use. All sealants must be used in strict accordance with the manufacturer's instructions and applied only by trained personnel to surfaces that have been properly prepared.
9. Sealant must be compatible with all materials with which they have contact, including other sealant surfaces. Consult the sealant manufacturer for recommendations relative to shelf life, compatibility, cleaning of substrate, priming, tooling adhesion, etc. Recommend sealant manufacturer perform adhesion "pull test" at "wet" glazing for quality assurance.
10. Drainage gutters and weep holes must be kept clean at all times. Tubelite will not accept responsibility for improper drainage as a result of clogged gutters and weep holes.
11. This product requires clearances at the head, sill and jambs to allow for thermal expansion and contraction as well as construction tolerances. Refer to final distribution drawings for joint sizes. Joints smaller than 1/2" may be subject to failure. Consult the sealant manufacturer for proper sizing of joints.
12. All framing members, entrances and other materials are to be installed plumb, level and true with regard to established bench marks, column center lines or other working points established by the general contractor and checked by the erector, installer and/or glazing contractor.
13. After sealant is set and a representative amount of the wall has been glazed (500 square feet or more), Tubelite recommends a water hose test to check installation. On large projects, a hose test should be repeated during glazing operation. This testing should be conducted in accordance with AAMA 501.2 specifications.
14. Cleaning of exposed aluminum surfaces should be done per AAMA recommendations.
15. Care must be taken when assembling aluminum framing components. Over tightening any fastener may cause stripping or fastener failure. Tubelite recommends the use of drill motors with clutches engaged to provide satisfactory tightening of the screw while preventing over torque. The use of impact drill motors is not recommended due to the absence of a clutch device.
16. Check www.tubeliteinc.com for any installation instruction updates.

GENERAL CONSTRUCTION NOTES

QUICK REFERENCE CHECKLIST

1. Make sure the opening is square and the caulk joints are $\frac{1}{2}$ " minimum around the frame.
2. Ensure surfaces that will be sealed are free of contaminants that can lead to adhesion issues.
3. Check that all weeps and baffles (if required) conforms to the locations and sizes called out in these instructions.
4. Butter seal ends of horizontal frame members that are joined to vertical members.
5. Water dam installation and sealing is critical. Check installation against instructions to ensure conformity.
6. Apply sealant between all corner gasket joints.
7. Glass bites must be equal on all sides.
8. Double check anchor size and location against installation instructions or approved shop drawings.
9. Ensure pressure plate fasteners are torqued to 60 in-lbs.

GLASS SIZE CALCULATION

(Glass size assumes MINIMUM 1/2" bite captured mullion. See approved shop drawings)

Captured Mullion	= D.L.O. + 1"
SSG Vertical Mullions	= D.L.O. + 2"
SSG Horizontal Mullions	= D.L.O. + 1 3/4"
SSG Vertical Mullion at Captured Jamb	= Width ONLY D.L.O. + 1 1/2"
Corner Mullions	= See Approved Shop Drawings

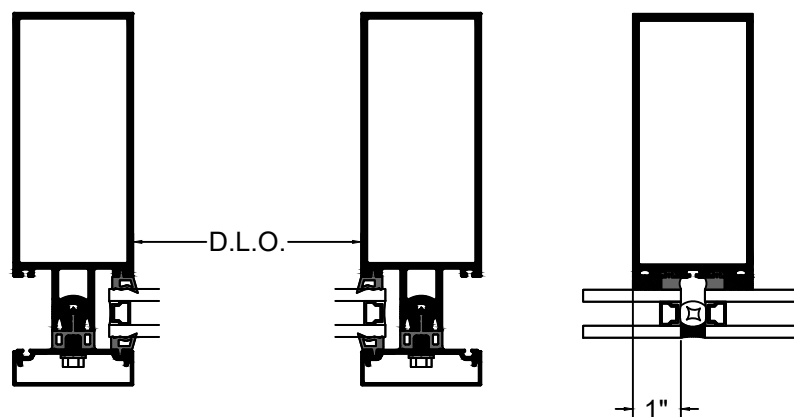







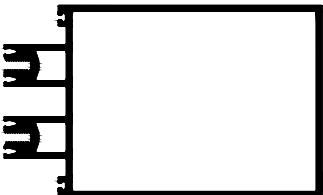

Fig.5.1

HORIZONTAL/VERTICAL EXTRUSIONS

SHAPE	DESCRIPTION	PART No.
	Captured Mullion/Horizontal	E55TB32FB
	Slide Over Horizontal	E55TB08FB
	Heavy Vertical	E55TB332FB
	SSG Back Member Horizontal/Vertical	E55TB140FB
	Open Back Perimeter	E55TB245FB
	Liveload Horizontal	E55TB182FB
	Roll Over Horizontal	E55TB03FB
	4" Horizontal/Vertical	E55TB151FB





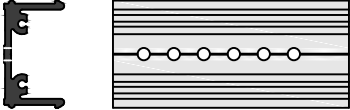
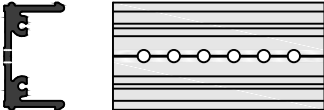
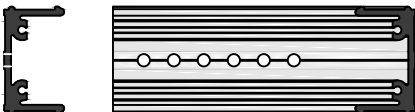
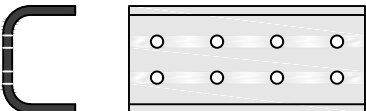
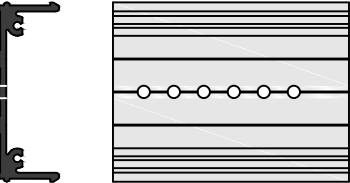
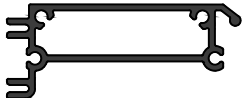
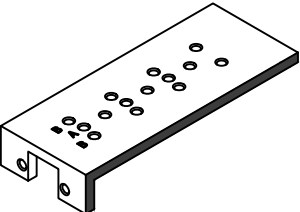







Contact www.tubeliteinc.com for additional system extrusions for enhanced project applications.

SHEAR BLOCK EXTRUSIONS and Drill Guide

SHAPE	DESCRIPTION	PART No.
	Shear Block for Horizontals Standard	PTB140FB
	Shear Block for Horizontals Slide Over	PTB141FB
	Shear Block for Horizontals Corner	PTB142FB
	Shear Block for Horizontals High Load	PTB143FB
	Shear Block for Horizontals 4" Horizontal	PTB144FB
	Shear Block for Roll Over Horizontal	PTB112
	Drill Guide	PTB149FB

Contact www.tubeliteinc.com for additional system extrusions for enhanced project applications.

TYPICAL FRAMING EXTRUSIONS

SHAPE	DESCRIPTION	PART No.
	Pressure Plate	M4TB224FB
	Perimeter Pressure Plate	M4TB325FB
	Pressure Plate 4" Width	M4TB290FB
	Pressure Plate Liveload Horizontal	M4TB324FB
	Screw Applied Horn	E4TB45FB
	Glass Pocket Filler	E4TB278FB
	Perimeter Anchor	E3162FB
	Setting Chair	P4623
	Snap In Adapter for 1/4" and 1/8" Glass	E4TB69FB
	Slide Over Horizontal Cap	E4TB84FB
	Snap In Filler For Rollover Horizontal	E55TB06FB
	2 1/2" Wide x 3/4" Snap Cover (Standard)	E4TB64FB
	4" Wide x 3/4" Snap Cover	E4TB285FB





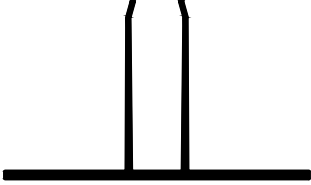
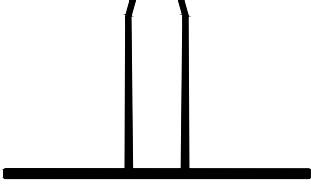
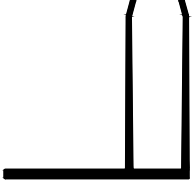
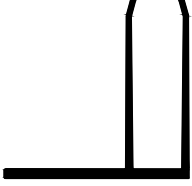
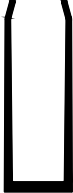



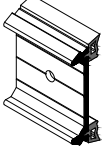

Contact www.tubeliteinc.com for additional system extrusions for enhanced project applications.

ANCHOR EXTRUSIONS

SHAPE	DESCRIPTION	PART No.
	<p>'T' Anchor for Standard and SSG Mullions</p>	<p>PTB11BFB</p>
	<p>'T' Anchor for Heavy Vertical Mullion</p>	<p>PTB11CFB</p>
	<p>'F' Anchor for Standard and SSG Mullions</p>	<p>PTB10BFB</p>
	<p>'F' Anchor for Heavy Vertical Mullion</p>	<p>PTB10CFB</p>
	<p>'U' Anchor for Door Jambs</p>	<p>P6516</p>







Contact www.tubeliteinc.com for additional system extrusions for enhanced project applications.

ACCESSORIES

SHAPE	DESCRIPTION	PART No.
	Temporary Glass Retainer	PTB194
	Water Dam for Captured Glazing	PTB103
	Thermal Isolator Gasket	PTB108
	1/8" Glazing Gasket	PTB28
	Typical Glazing Gasket	P4606
	SSG 1/4" Gasket	P4631
	Optional Infill Glazing Gasket	PTB33
	Optional Infill Glazing Gasket	PTB31
	Setting Block for 1" Glazing	P946
	Setting Block for 1/4" Glass	P948
	Setting Block for SSG Horizontal	P4603

Contact www.tubeliteinc.com for additional system extrusions for enhanced project applications.

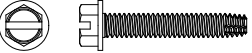
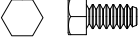
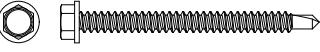
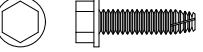
FASTENERS

SHAPE	DESCRIPTION	PART No.
	#10-24 x 1/2" PH type 'F' For Roll Over Horizontal	S128
	#14-14 x 1/2" HH type 'F' Stainless Steel 18-8 For Shear Blocks (Refer to Approved Shop Drawings for For Correct Usage)	S139
	#10-24 x 1 1/2" For Steel Reinforcement	S207
	1/4-20 x 2 1/4" For Captured Outside Corner	S211
	#10-24 x 3/4" PH Self Tapping For Fastening Horizontal to Shear Block	S270
	1/4 -20 x 1 1/2" Type 'F' Stainless Steel 18-8 For Roll Over Shear Clip	S359
	#14-14 x 1/2" HH Type 'F' Grade 8 For Shear Blocks (Refer to Approved Shop Drawings for For Correct Usage)	S410
	#12-14 x 2 1/2" For Optional Screw Applied Horn	S466
	1/4-20 x 1" Type 'F' Grade 5 For Pressure Bars	S469
	1/4-20 x 2 1/2" For Standard Outside SSG Corner	S473

Contact www.tubeliteinc.com for additional system extrusions for enhanced project applications.

ELEVATION and WALL SECTION

The 400T Series Blast Resistant curtain wall system is designed for single and multi span construction.

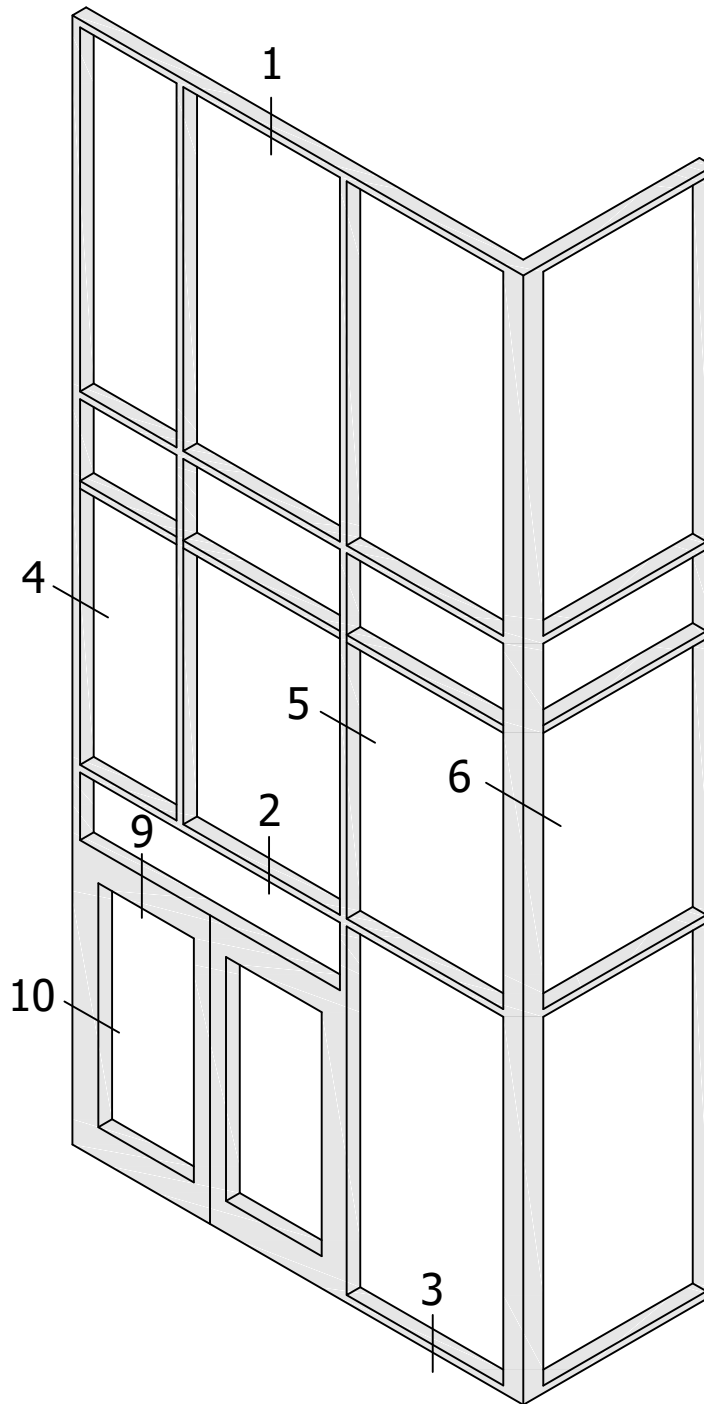
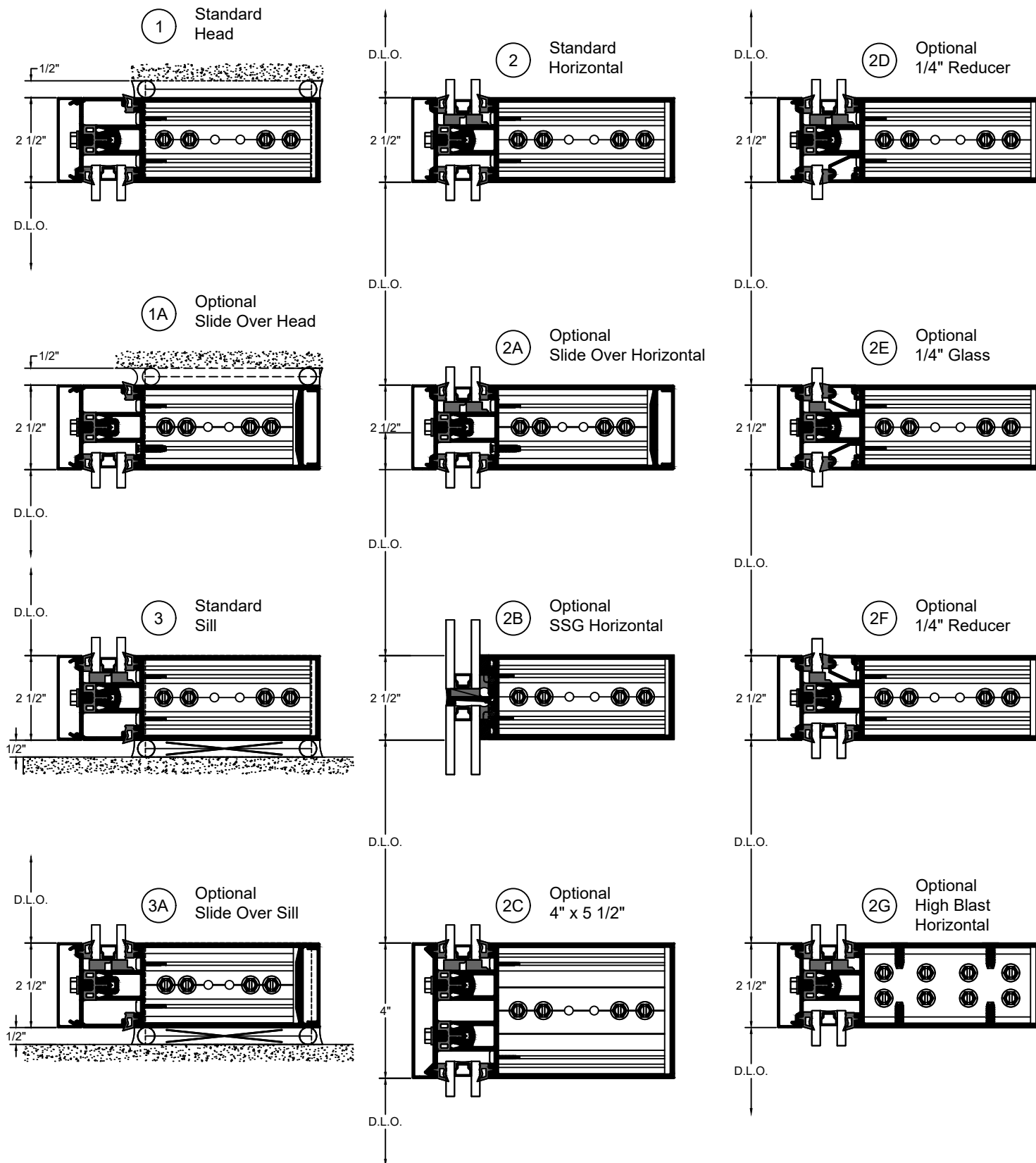

Fig.12.1

Contact www.tubeliteinc.com for additional system extrusions for enhanced project applications.

TYPICAL HORIZONTAL DETAILS

Four screws per shear block shown, consult approved shop drawing for amount of screws for your application



TYPICAL VERTICAL DETAILS

④ Standard Jamb

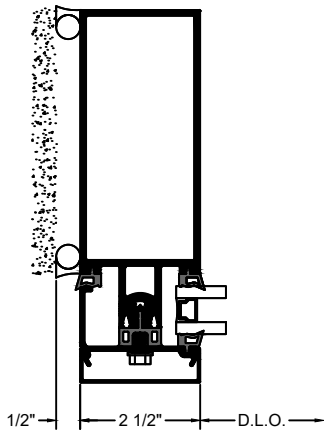

④A Optional Heavy Wall Jamb

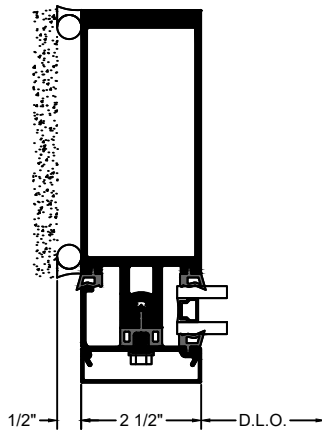

④ Optional Jamb with "F" Jamb Anchor

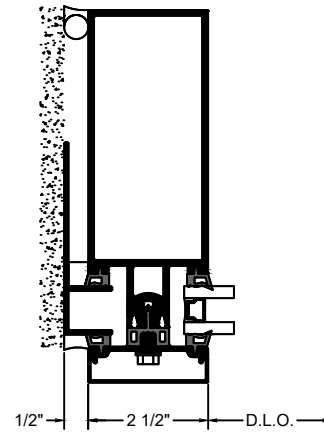

⑤ Standard Intermediate Vertical

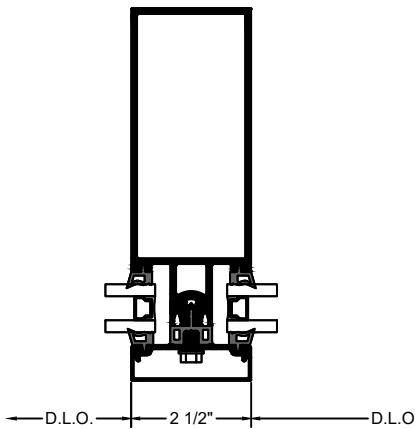

④A Optional Heavy Wall Intermediate Vertical

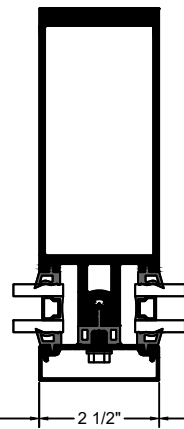

④ Optional Silicone Glazed Vertical

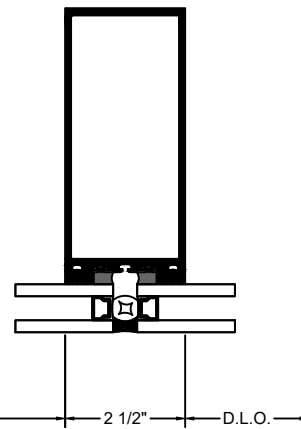

⑤C Optional Silicone Glazed Vertical SSG 1/4" Glass

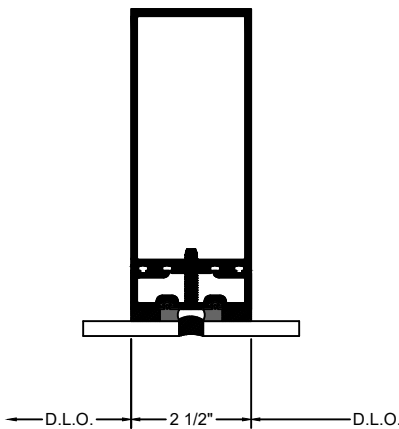

⑤D Optional 4" x 5 1/2" Vertical

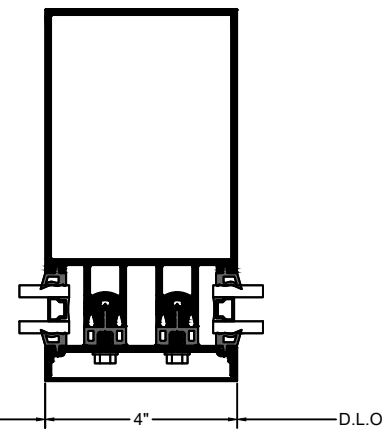

⑤E Optional Screw Applied Horn

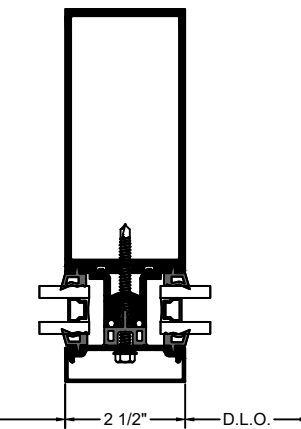

TYPICAL CORNER DETAILS

6 Standard Outside Corner

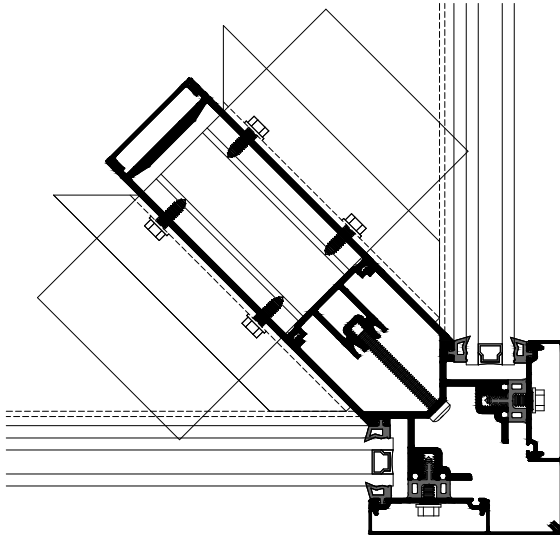

6A Standard 90° Outside Corner - SSG

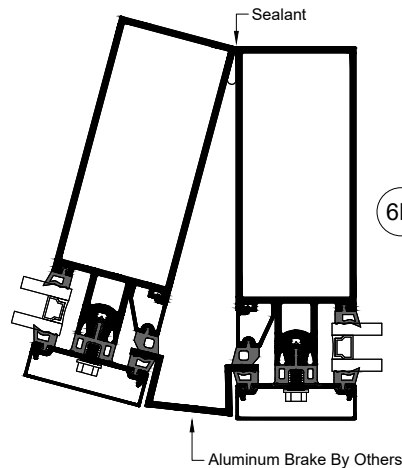
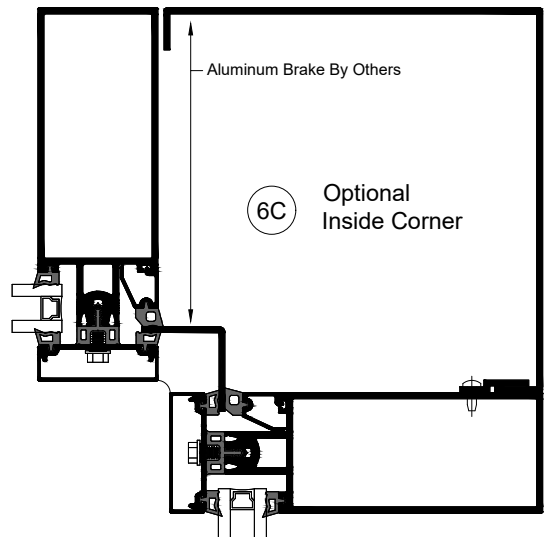
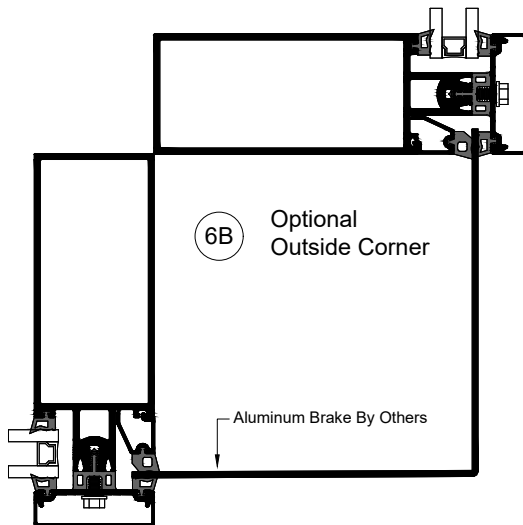
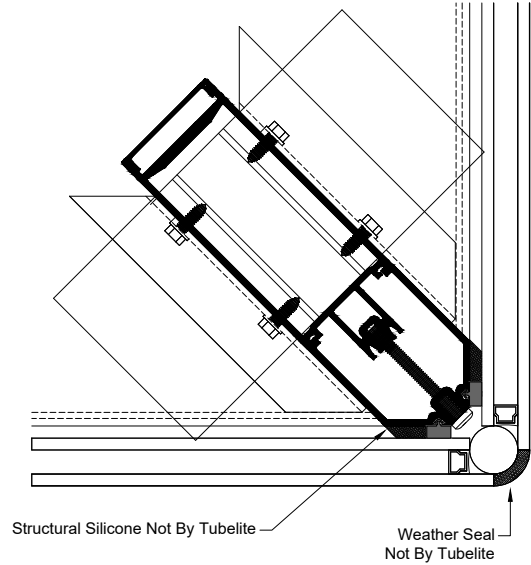

TYPICAL TRANSOM AND DOOR DETAILS

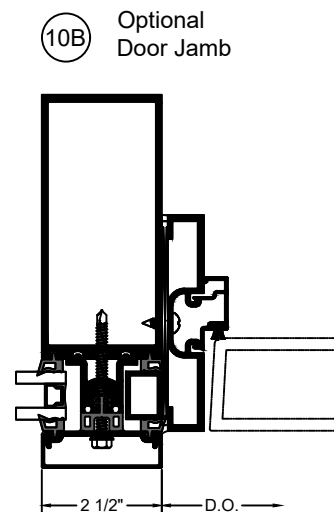
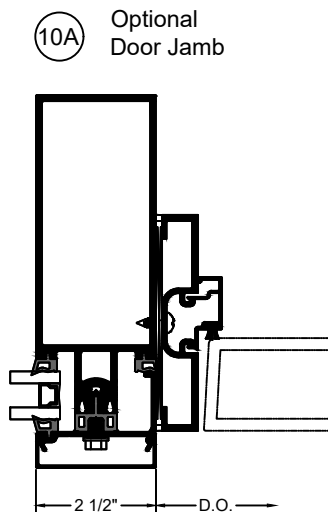
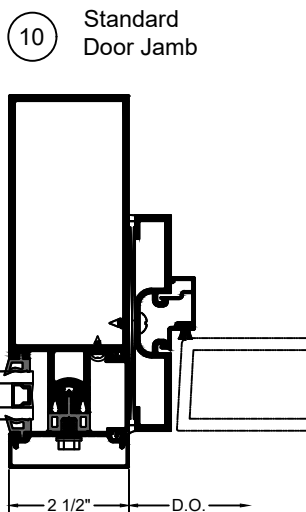
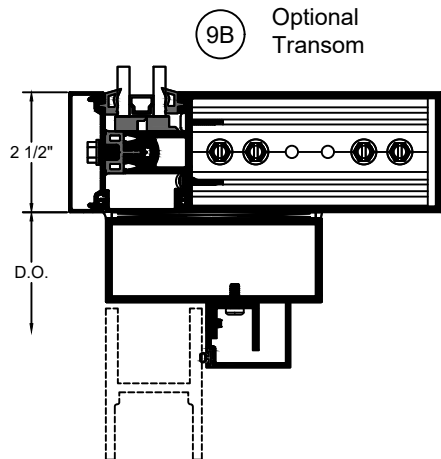
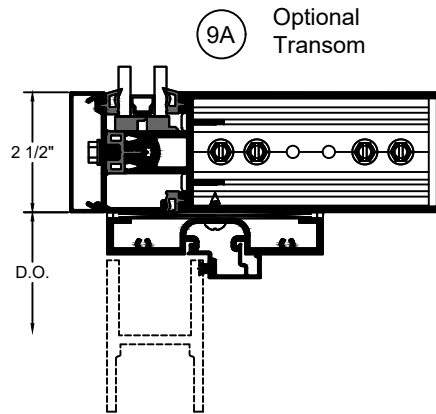
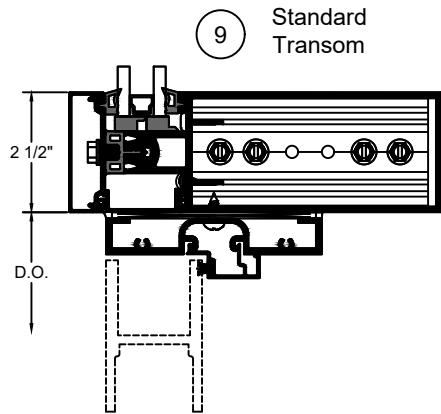

OPEN BACK DETAILS

**PLEASE CONTACT TUBELITE ENGINEERING
BEFORE USING OPEN BACK EXTRUSIONS**

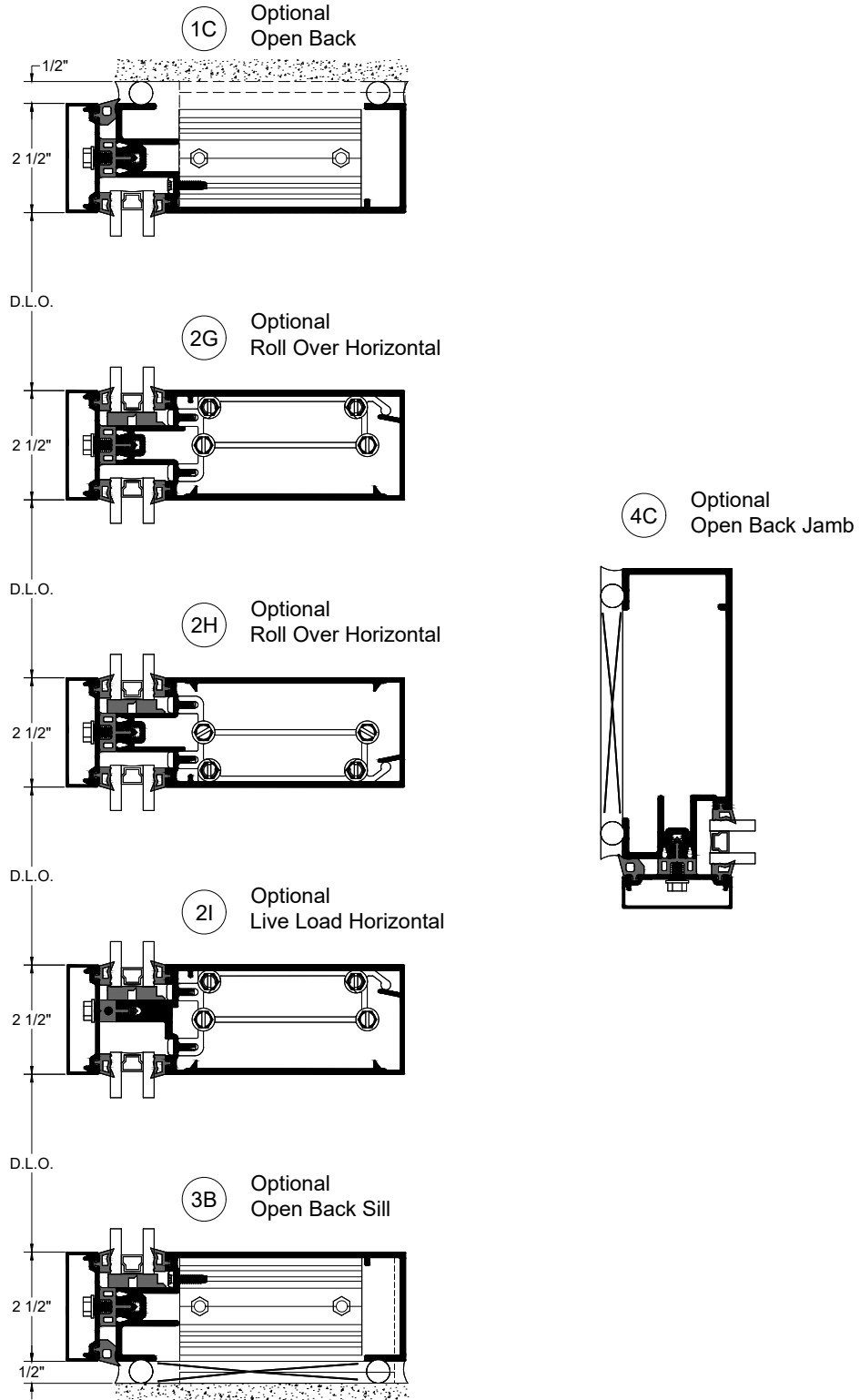

FRAME FABRICATION

Step 1: Determine Frame Size

Frame Width

- A. Make sure the opening is square and plumb. Measure each diagonal of the opening. **SEE Fig.18.1**
- B. Measure the width of the opening (Rough Opening) at the top, middle, and bottom. Select the smallest of these dimensions and subtract the left and right caulk joint width per approved shop drawing (1/2" minimum caulk joint at jambs). **SEE Fig.18.2**
- C. Allow a larger clearance to accommodate building tolerances, an out-of-square opening, anticipated thermal expansion within the unit, or as required by shop drawings.

Frame Height

- D. Measure the height of the opening (Rough Opening) at several points along the entire width of the opening. Select the smallest of these dimensions and subtract 1" to allow a minimum of 1/2" at sill and head for shim and caulking. **SEE Fig.18.3**
- E. Allow a larger clearance to accommodate building tolerances, an out-of-square opening, anticipated thermal expansion within the unit, or as required by shop drawings.

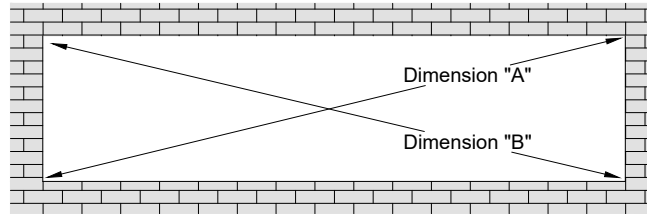

Fig.18.1
Dimension "A" = "B"

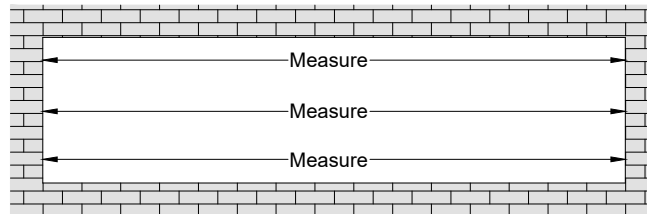

Fig.18.2

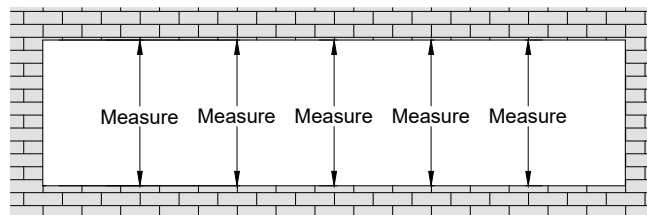

Fig.18.3

FRAME FABRICATION

Step 2: Cut Materials to Size

Captured Framing

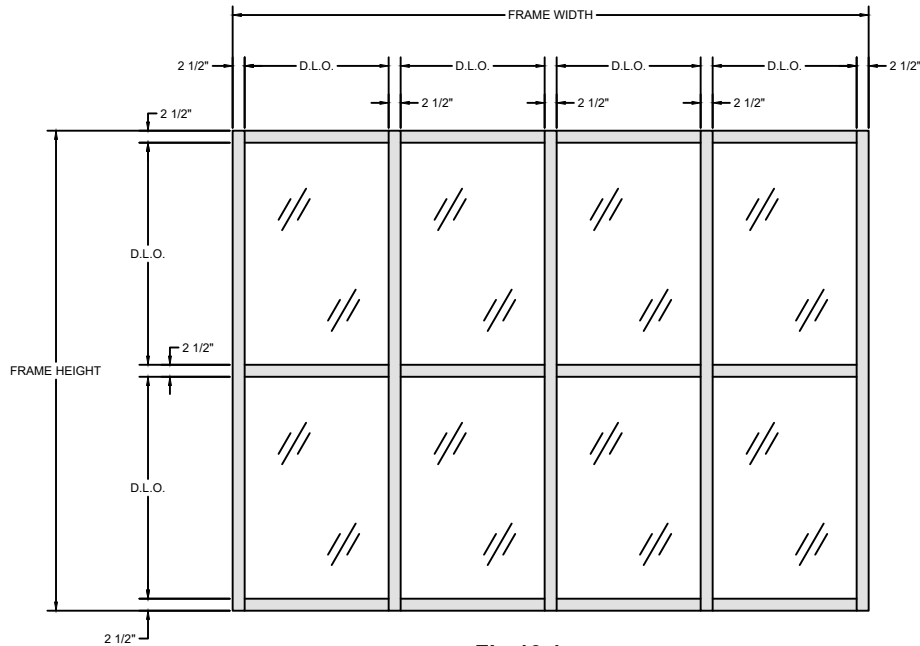

Fig.19.1

Cut extrusions to lengths as shown below:

Vertical Profiles:

Vertical Mullion	= Frame Height
Pressure Plates	= Frame Height
Face Caps	= Frame Height
Pocket Filler at Perimeter	= D.L.O. <i>MINUS</i> (-) 1/16" used with PTB120 thermal pressure plate

Horizontal Profiles:

Head, Sill, & Horizontal	= D.L.O.
Pressure Plates	= D.L.O. <i>MINUS</i> (-) 3/8"
Face Caps	= D.L.O. <i>MINUS</i> (-) 1/32"
Pocket Filler at Perimeter	= D.L.O. <i>MINUS</i> (-) 1/16"

Accessories:

Exterior Vertical Gasket	= Pressure Plate Length <i>PLUS</i> (+) Allowance*
Exterior Horizontal Gasket	= Pressure Plate Length <i>PLUS</i> (+) Allowance*
Interior Vertical Gasket	= D.L.O. <i>PLUS</i> (+) 1" <i>PLUS</i> (+) Allowance*
Interior Horizontal Gasket	= D.L.O. <i>PLUS</i> (+) Allowance*

*Allowance = 1/8" extra length per foot of D.L.O. or aluminum length

Note: Door framing material is cut to size from the factory.

FRAME FABRICATION

Step 2: Cut Materials to Size (Continued)

SSG Framing

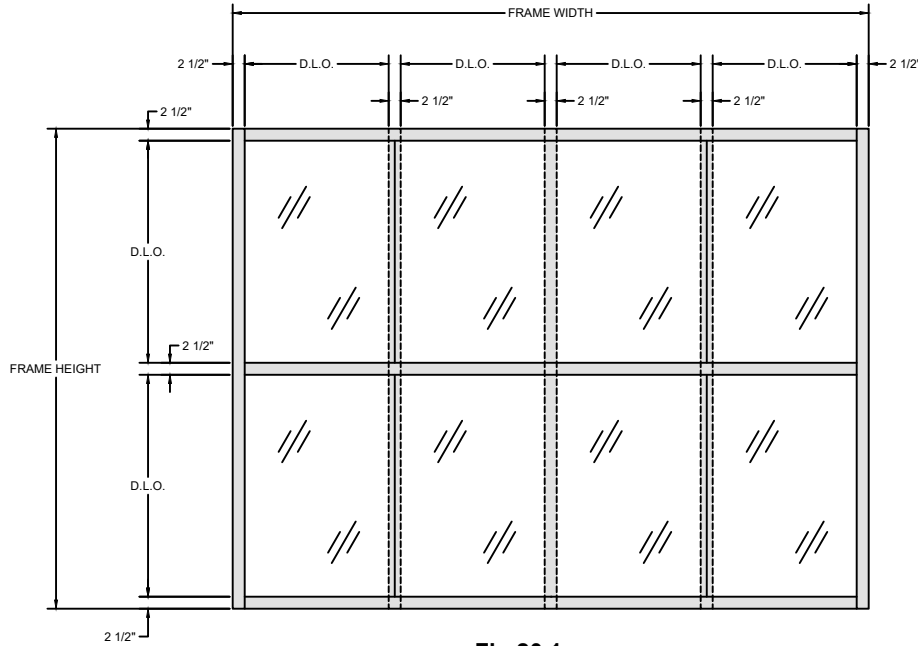

Fig.20.1

Cut extrusions to lengths as shown below:

Vertical Profiles:

- Vertical Mullion = Frame Height
- Pressure Plates (at Jambs) = Frame Height
- Face Caps (at Jambs) = Frame Height
- Glazing Adaptors = D.L.O. *PLUS* (+) 1"
- Pocket Filler at Perimeter = D.L.O. *MINUS* (-) 1/16" (used with PTB120 thermal pressure plate)

Horizontal Profiles:

- Tubular Head, Sill, & Horizontal = D.L.O.
- Open Back Head, Sill, & Horizontal = D.L.O. *MINUS* (-) 1/32"
- Pressure Plates = 3 Lites Wide Maximum
- Face Caps = 3 Lites Wide Maximum
- Glazing Adaptors = D.L.O. *MINUS* (-) 1/32"

Accessories:

- Exterior Vertical Gasket (at Jambs) = Pressure Plate Length *PLUS* (+) Allowance*
- Exterior Horizontal Gasket = Pressure Plate Length *PLUS* (+) Allowance*
- Interior Vertical Gasket = D.L.O. *PLUS* (+) 1" *PLUS* (+) Allowance*
- Interior Horizontal Gasket = D.L.O. *PLUS* (+) Allowance*
- Interior Horizontal Gasket = D.L.O. *PLUS* (+) 1" *PLUS* (+) Allowance*

*Allowance = 1/8" extra length per foot of D.L.O. or aluminum length

FRAME FABRICATION

Step 3: Drill Holes in Vertical Members for Shear Blocks

- A. Drill .201" diameter pilot holes for #14 screws in the vertical members. Use the PTB149FB drill fixture to locate these holes. Holes in rows marked "B" are for high load shear block, row marked "A" for all other shear blocks.

Standard and Slide Over
Shear Block Pattern (A)

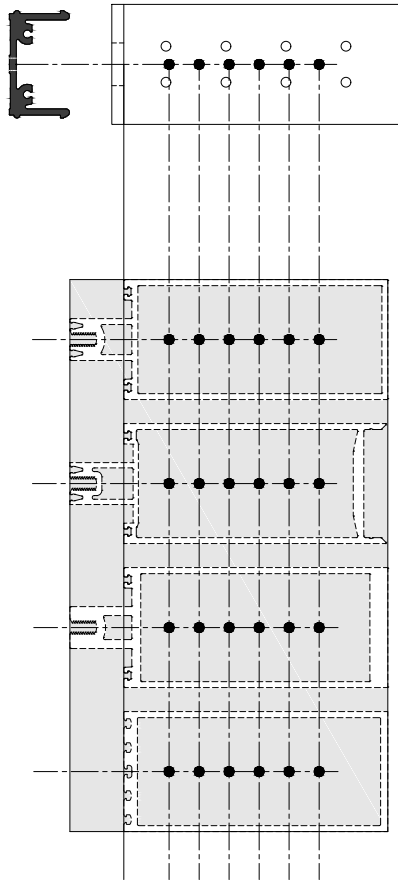

Fig.21.1
Standard and Slide Over
Shear Block Pattern

High Load
Shear Block Pattern (B)

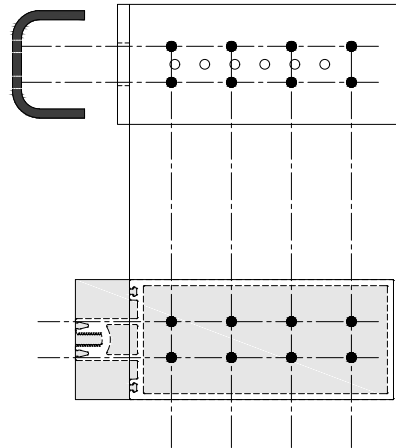

Fig.21.2
High Load
Shear Block Pattern

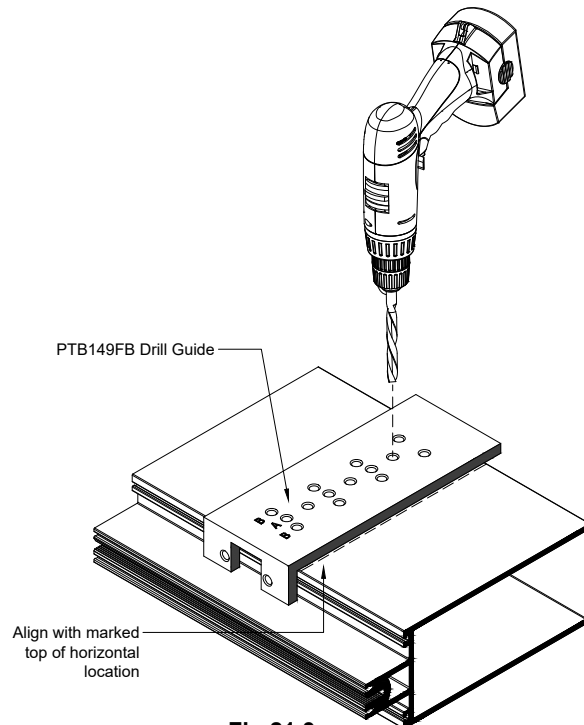

Fig.21.3

FRAME FABRICATION

Step 4: Drill Holes in Horizontal for Attachment to Shear Blocks

- A. Drill .201" diameter clearance holes for #10 screws in the horizontal sections for attachment to the shear blocks. Use PTB149FB drill fixture to locate holes. See **Fig.22.1**.

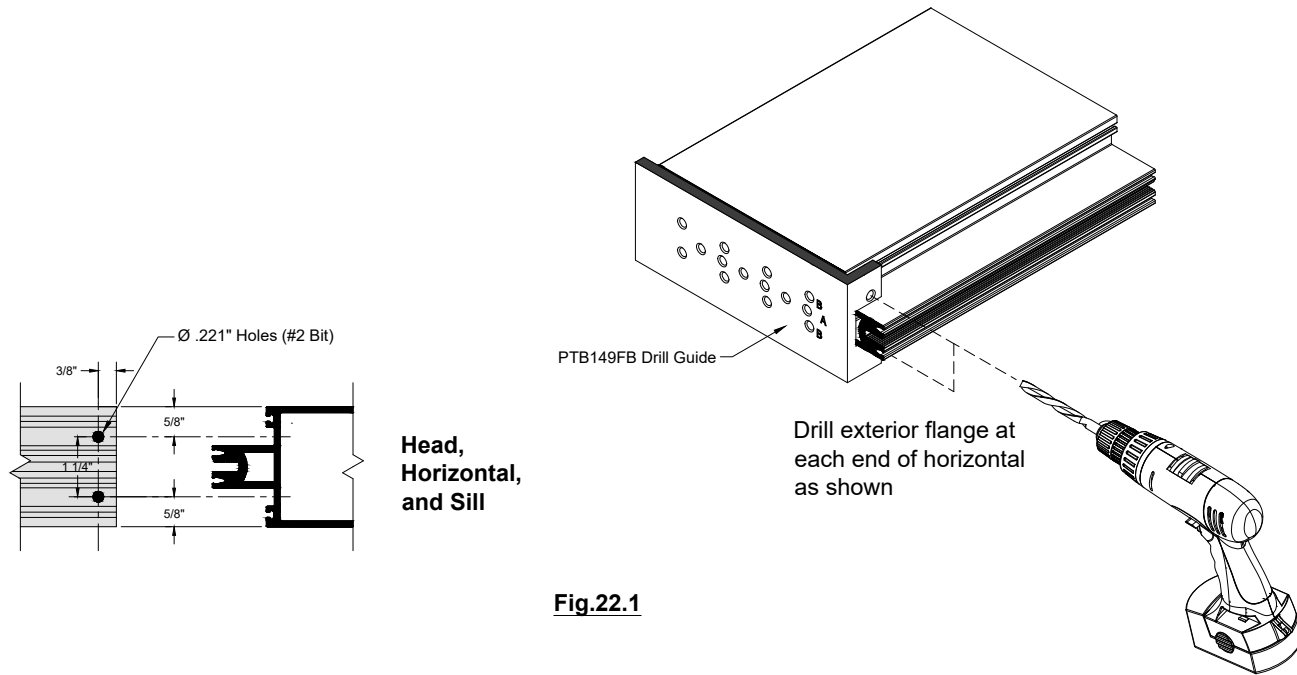
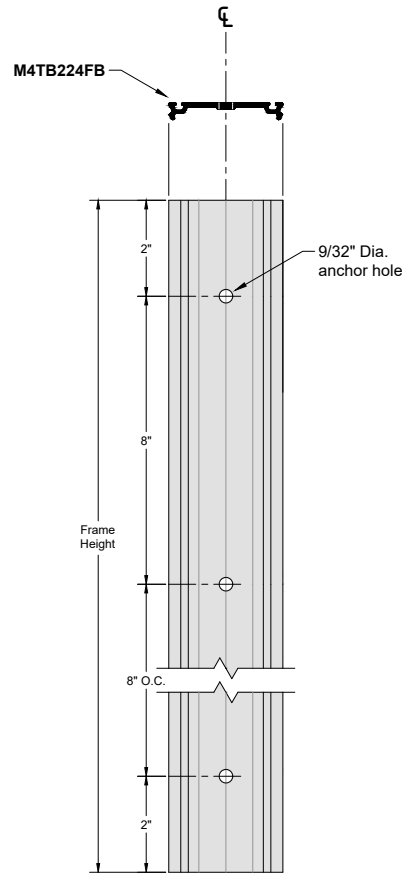

Fig.22.1

FRAME FABRICATION

Step 5: Drill Weep Holes in Horizontal Pressure Plates

- Drill 5/16" diameter weep holes in horizontal pressure plate at 1/4 points at each end. Locate the holes on the V-groove above the center line of the pressure plate.
- Pressure plates are factory punched on the center for pressure plate screws. Drill additional hole(s) as required to ensure a maximum of 2" from the ends of the plates.



VERTICAL PRESSURE PLATE

Fig.23.1

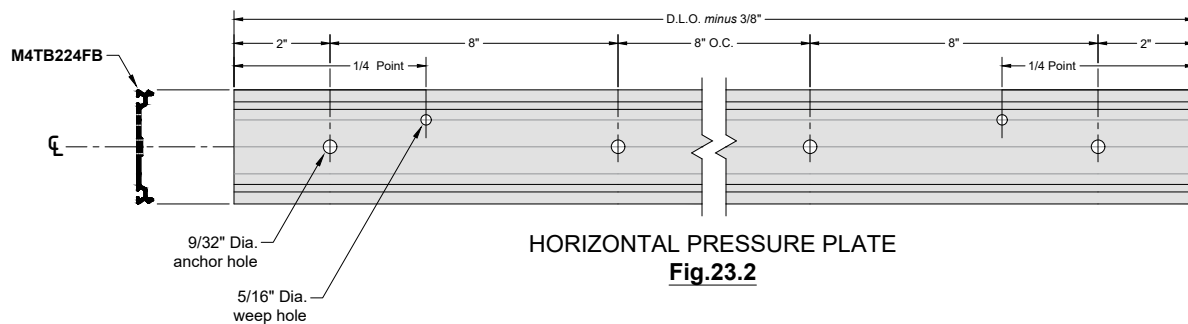

HORIZONTAL PRESSURE PLATE

Fig.23.2

FRAME FABRICATION

Step 6: Fabricate Weep Holes in Horizontal Face Covers

- A. Drill a 5/16" diameter weep hole on the bottom of each horizontal face cover a maximum of 1" from each end of the cover.

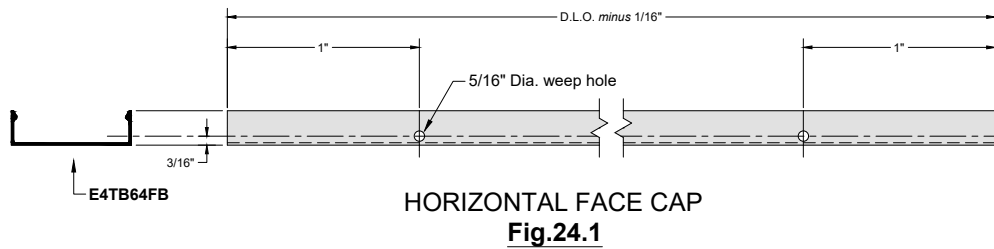

Step 7: Notch Heads and Sills to Clear Shear Clips

- A. Notches must be cut in the slide over horizontal members to provide clearance for the shear blocks. Standard horizontal not to be notched.
 See **Fig.24.2** for proper notch size.

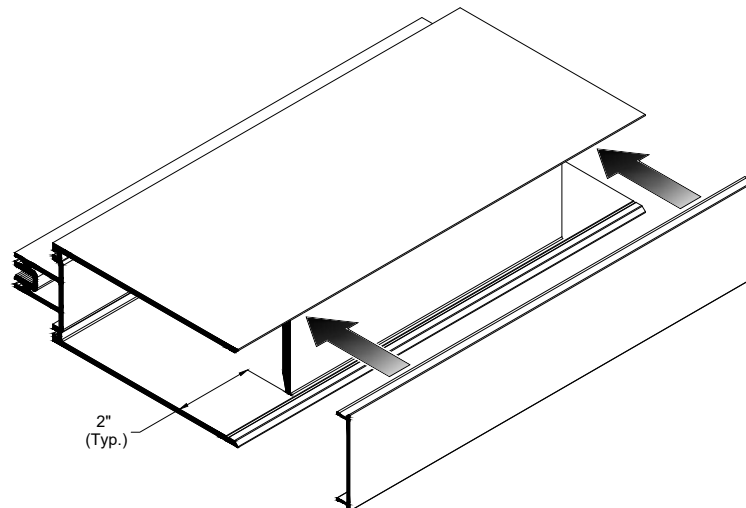

Fig.24.2

FRAME FABRICATION

Step 8: Fabricate F-Clip Perimeter Anchor (OPTIONAL)

- A. Cut and fabricate to fit along the vertical as shown in **Fig.25.1**.
Vertical anchor clip runs continuous from head to sill.

NOTE: F-Clip is optional to limit jamb mullion deflection. See approved shop drawings.

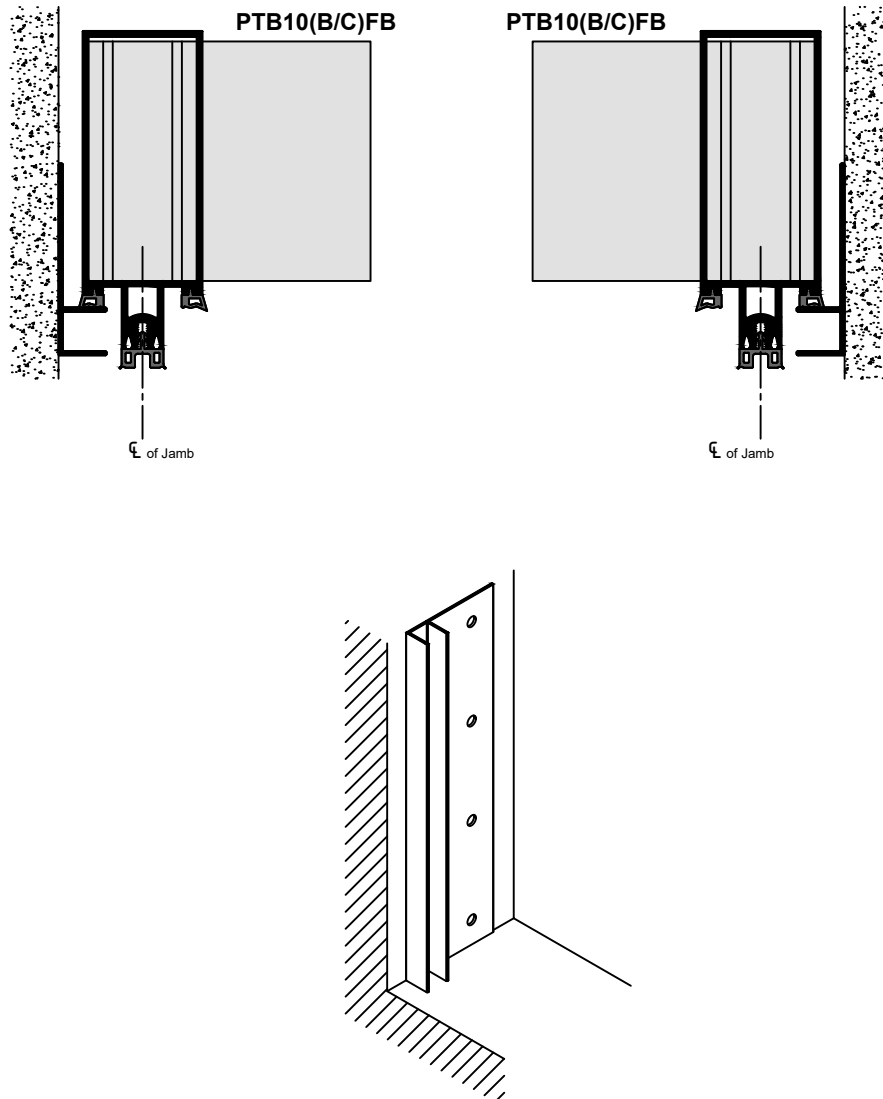

Fig.25.1
Optional F Anchor Extrusion

FRAME FABRICATION

Step 9: Install Steel Reinforcement As Required

- A. Refer to approved shop drawings to determine where steel reinforcing may be required.
- B. Steel should be installed prior to the attachment of shear blocks.
- C. Steel should be sized to stop short of the top and bottom of the vertical for clearance.
- D. Locate and prep for attachment of the steel located under the horizontal shear blocks if possible. Otherwise, steel can be secured to the vertical mullion through the tongue. Anchor the steel to the vertical using fasteners and spacing per approved shop drawings (not supplied by Tubelite).

Captured Mullion

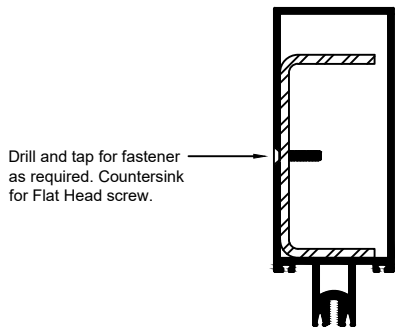

Steel reinforcement shown is for reference only.
See approved shop drawing for steel requirements.

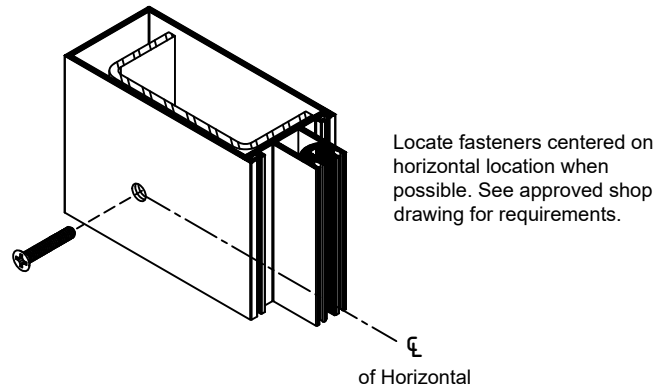

TYPICAL APPLICATION
Fig.26.1

Captured Mullion

E55TB32FB

E55TB332FB

E55TB140FB

E55TB32FB
Optional
4 1/2" x 1 3/4" Steel Bar

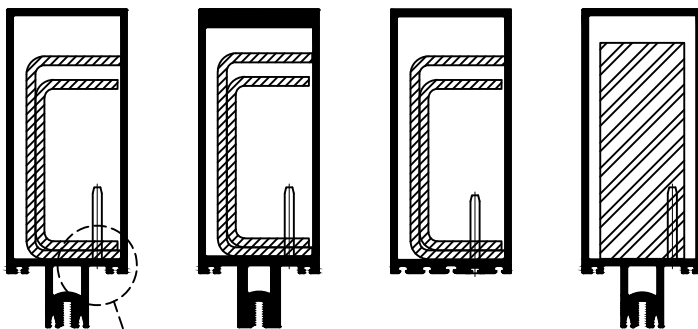

Steel reinforcement shown is for reference only.
See approved shop drawing for steel requirements.

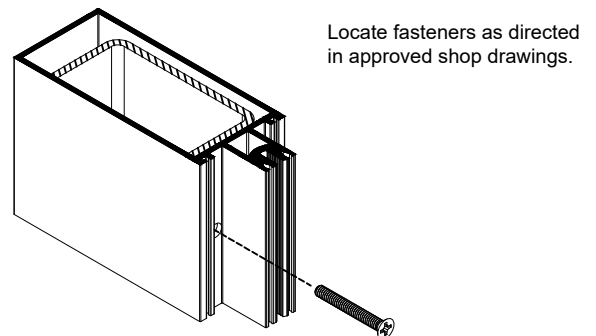

OPTIONAL APPLICATION
Fig.26.2

FRAME FABRICATION

Step 10: Fasten Shear Block to Vertical

- A. Fasten the shear blocks for tubular horizontals to the verticals using S139 or S410 fasteners, depending on structural load requirements. Consult approved shop drawing for fastener type and number of fasteners per clip.
- B. Fasten the shear clips for roll-over horizontals to the verticals using S359 fasteners.

NOTE: If steel reinforcement is required, it must be installed prior to shear block attachment.

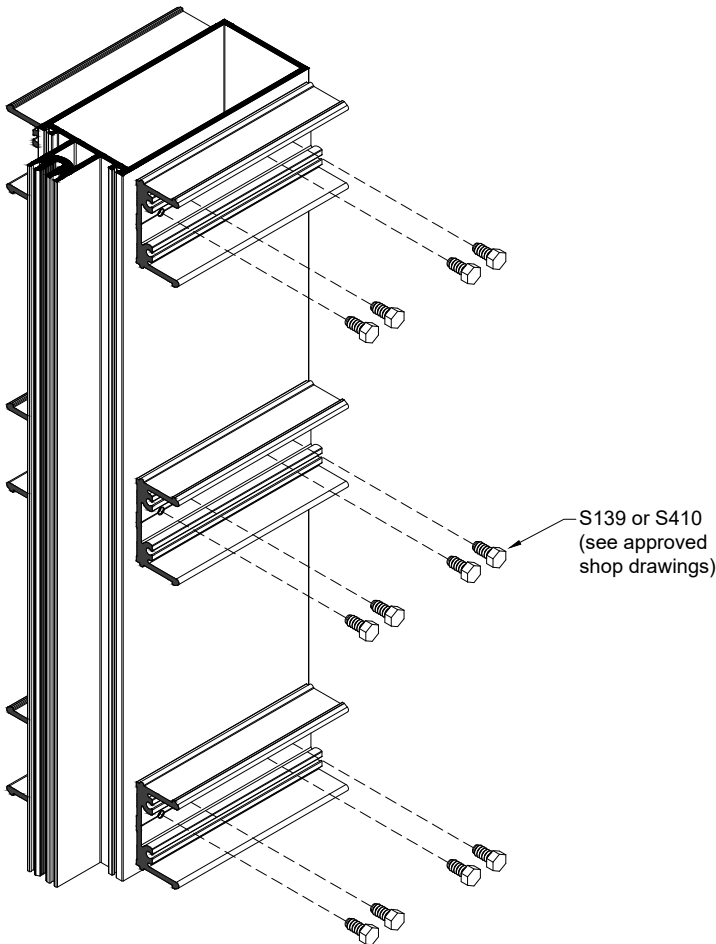

Shear Block Attachment
for Tubular Horizontals
Fig.27.1

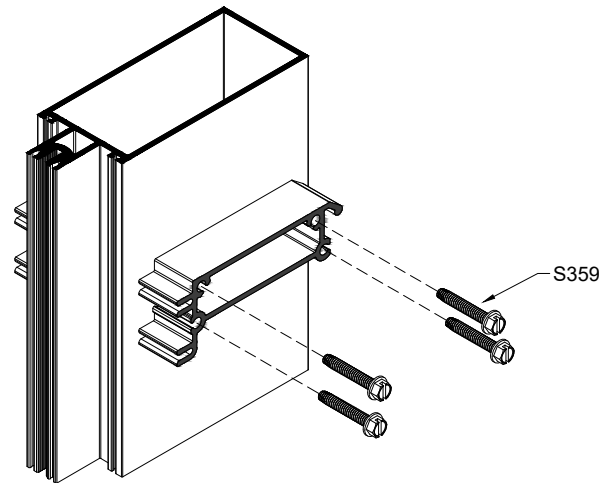

Shear Block Attachment
for Roll-Over Horizontals
Fig.27.2

FRAME FABRICATION

Step 11: Install Head and Sill 'F' and 'T' Anchors

- A. Fasten a shear block to the vertical mullion using S139 screws at the head or sill.
Refer to Step 10 for shear block installation.
- B. F and T anchors can be pre-loaded into the top and bottom of the verticals and temporarily secured with tape for transit to the job site.

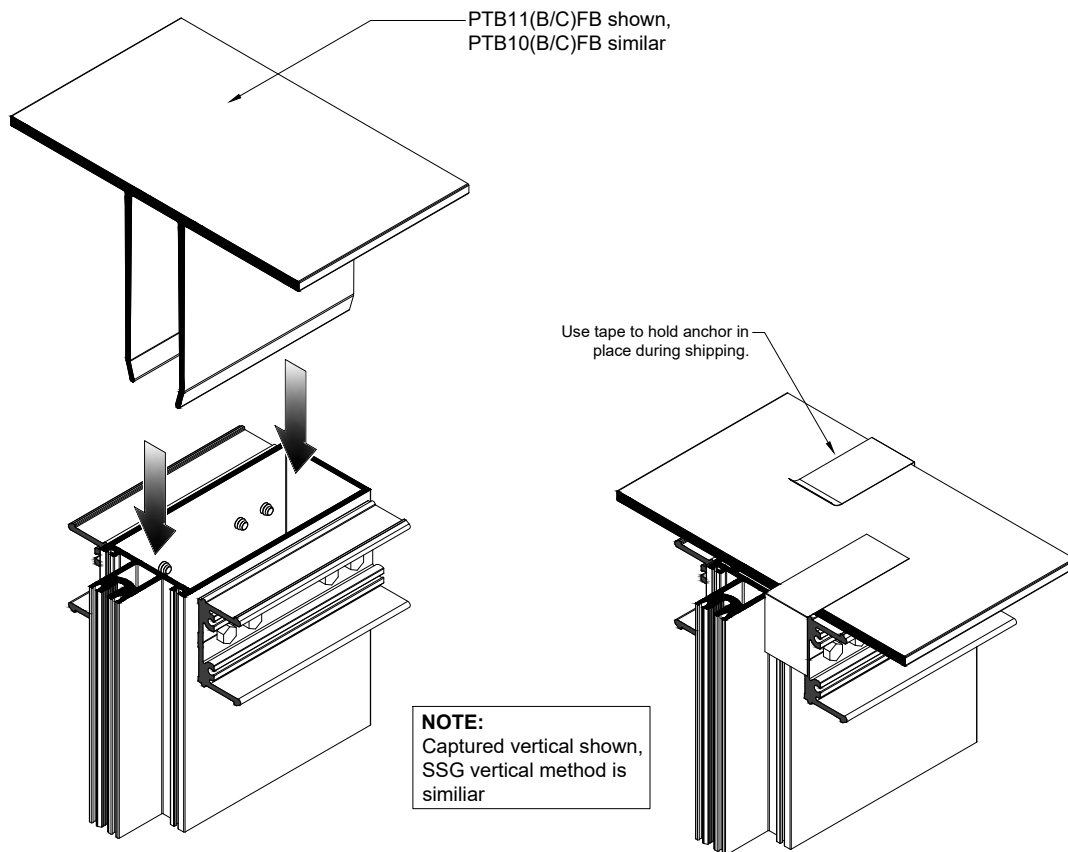

Fig.28.1

FRAME INSTALLATION

Step 12: Installing Vertical Mullions

NOTE: Check D.L.O. and diagonal dimensions every four bays to ensure correct spacing and frame squareness.

T or F Anchor Installation

- A. Install vertical mullions plumb and level, shimming between the bottom of the vertical and T or F anchor for proper deadload distribution.
- B. Anchor Top F anchor to building per approved shop drawings.

NOTE: Do not shim the top of the vertical to allow for thermal and liveload movement.

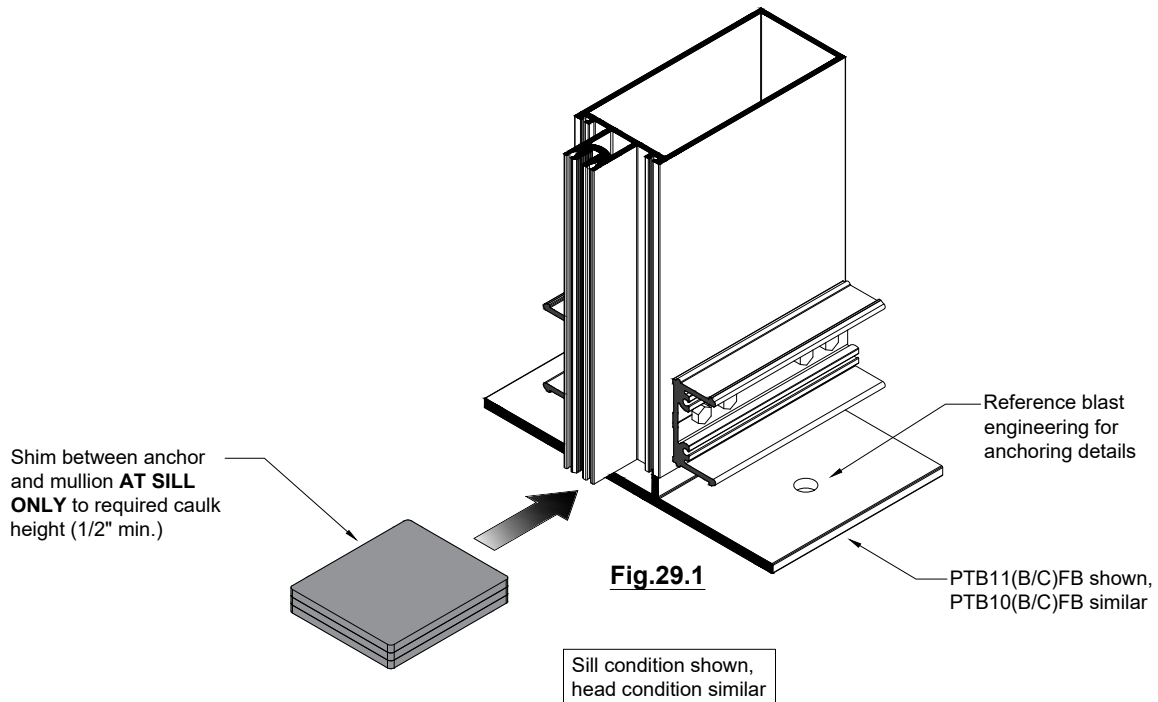

FRAME FABRICATION

Step 13: Attach Horizontals to Shear Blocks and Anchor Clips

- A. Seal shear block prior to installing the horizontal member. See **Fig.30.1**.
- B. Seal the ends of the horizontal back member and attach to the shear block using S270 screws. Seal the heads of the screws as shown in **Fig.30.2**.
- C. Tool sealant at the horizontal/vertical intersection. See **Fig.30.3**.

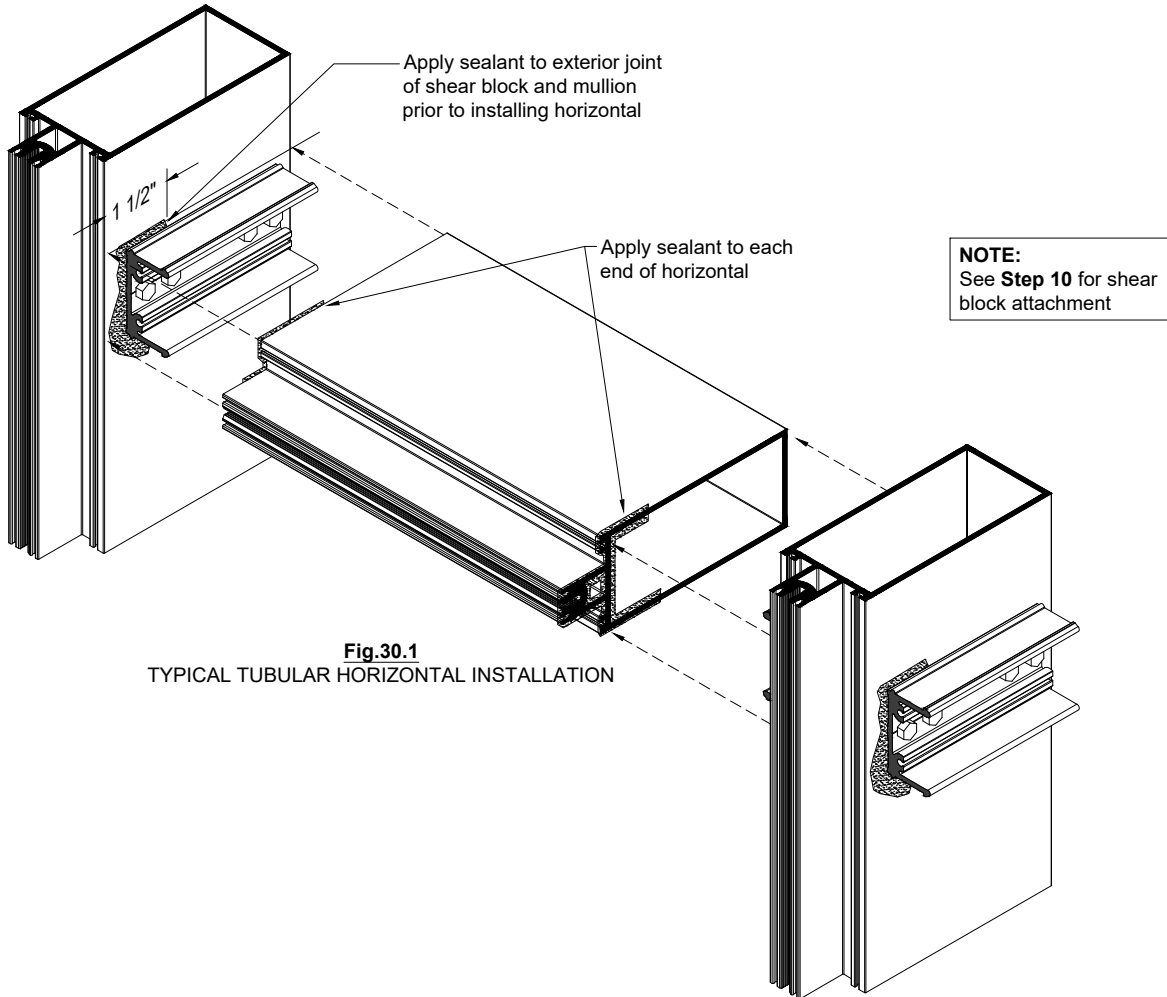

Fig.30.1
TYPICAL TUBULAR HORIZONTAL INSTALLATION

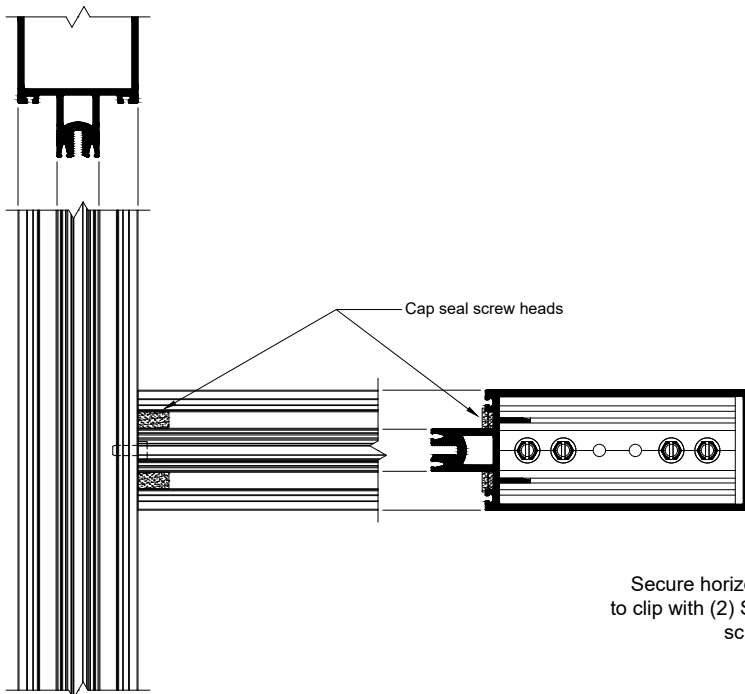

Fig.30.2

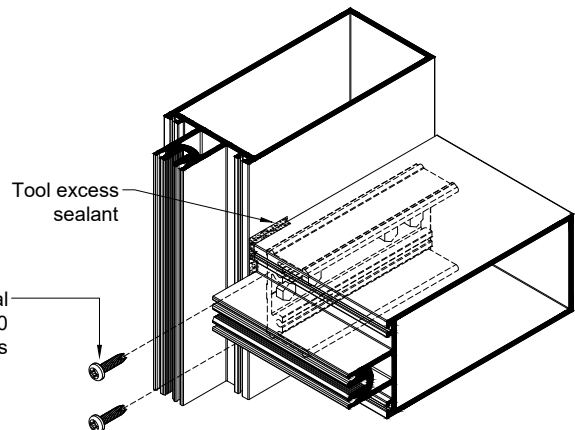
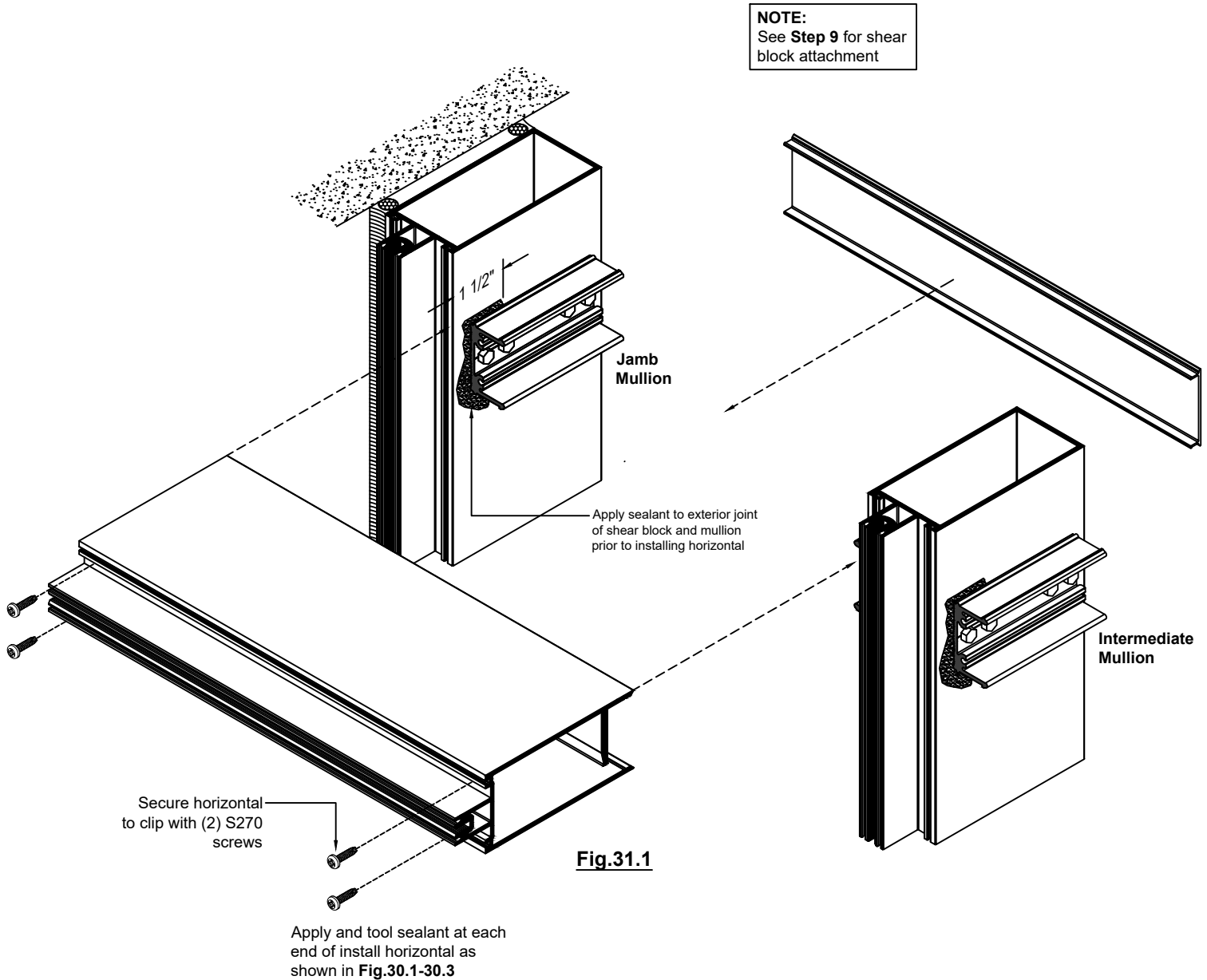

Fig.30.3

FRAME INSTALLATION

Step 13: Attach Horizontals to Shear Blocks and Anchor Clips (Continued)

LAST BAY TUBULAR HORIZONTAL INSTALLATION



FRAME INSTALLATION

Step 13: Attach Horizontals to Shear Blocks and Anchor Clips

D. When roll-over horizontal is used, seal face of clip, horizontal ends, and screw heads. See **Fig.32.1**, **Fig.32.2**, and **Fig.32.3**.

NOTE: See **Step 10** for shear block attachment

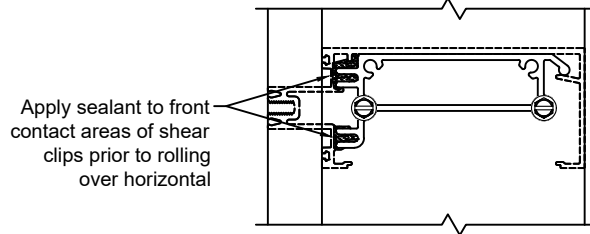
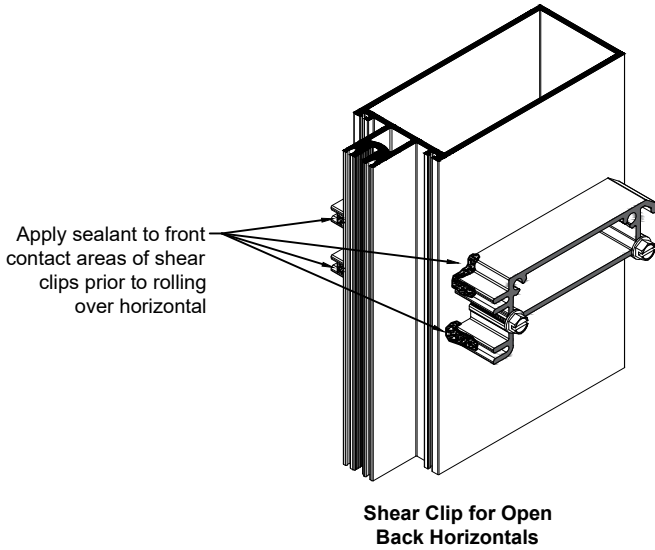

Fig.32.1

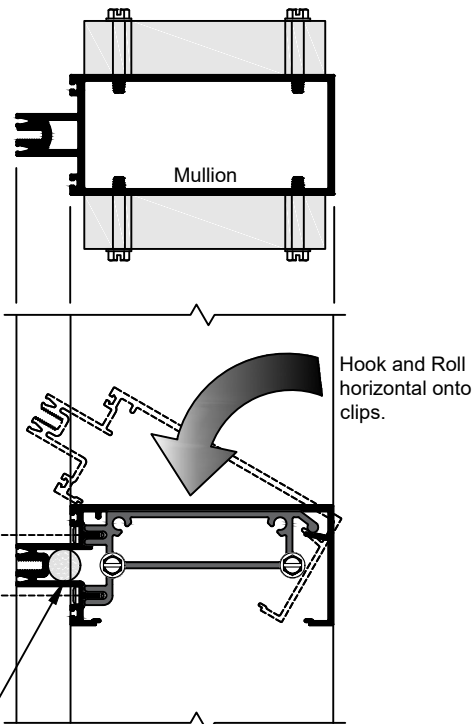
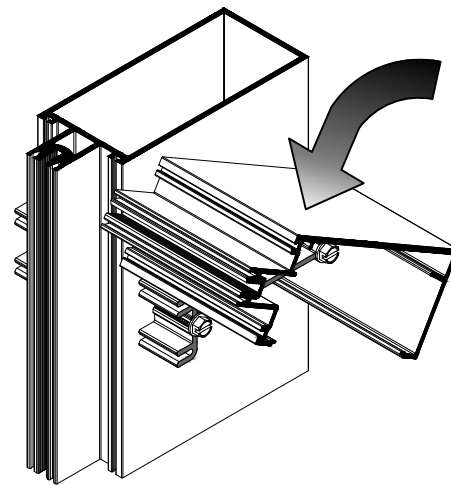

Fig.32.2



Shear Clip for Open Back Horizontals

Fig.32.3

Install P1094 ethafoam rod as shown

FRAME INSTALLATION

Step 14: Install Water Dams

- A. Seal the end of the horizontal member across the vertical member. This sealant should be applied liberally.
- B. Push the PTB103 water dam into the void between the horizontal member and the vertical tongue. This is a pressure fit; the water dam should be level with the top of the horizontal tongue.
- C. Seal over the top of the PTB103 onto the horizontal tongue, damming the end of the horizontals. THIS IS A CRITICAL SEAL. See Fig. 33.2.

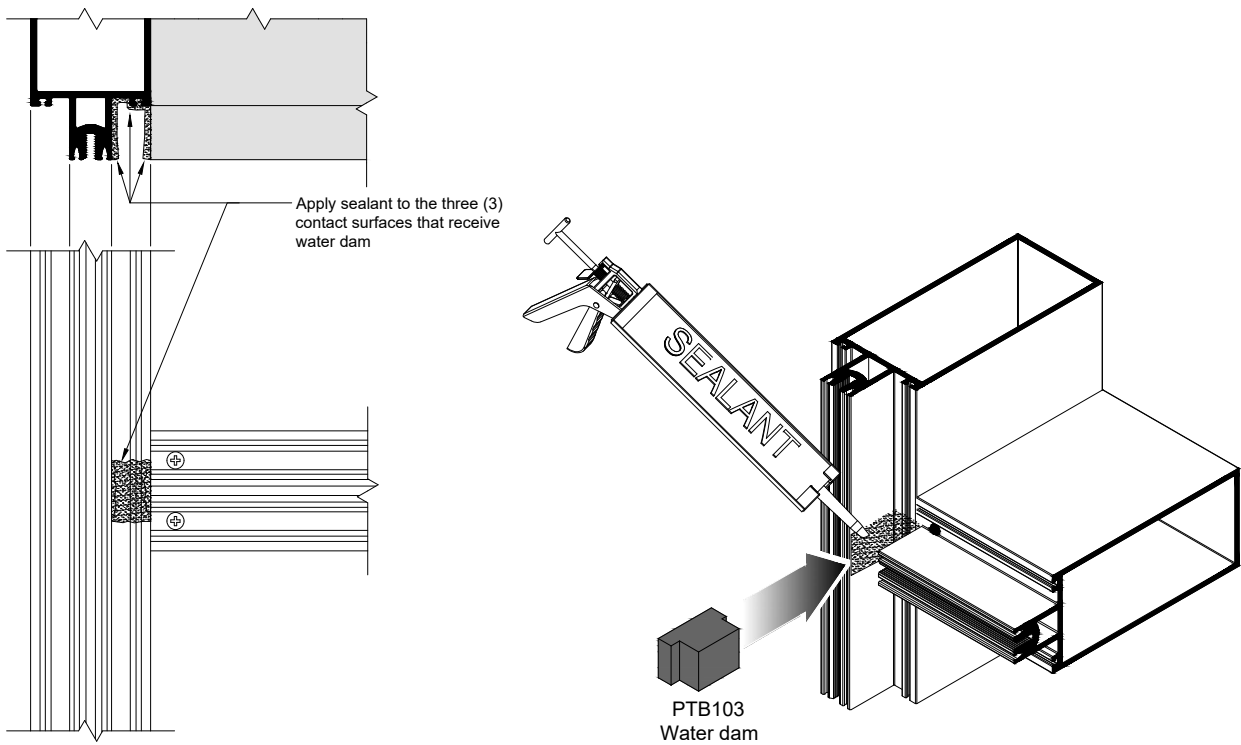

Fig.33.1

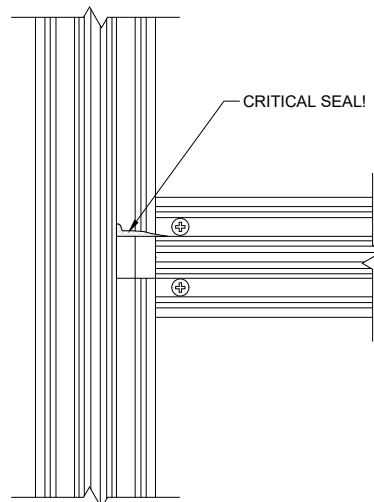

Fig.33.2

FRAME INSTALLATION

Step 15: Seal Perimeter of Installation

- A. Apply sealant into gasket reglet as shown in **Fig.34.1**.
- B. Insert backer rod into the gap between the building substrate and curtain wall frame.
- C. Apply sealant around the perimeter of the frame and tool the sealant. See **Fig.34.2** and **Fig.34.3**.

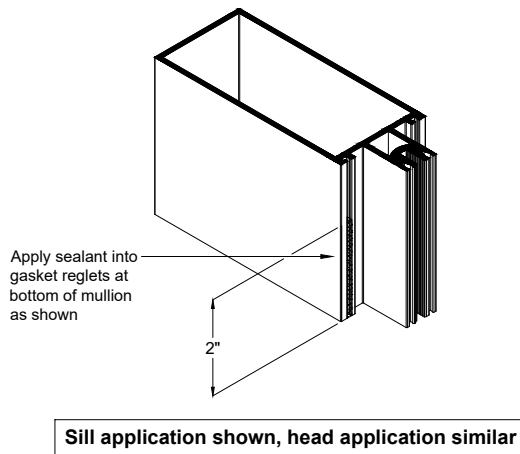

Fig.34.1

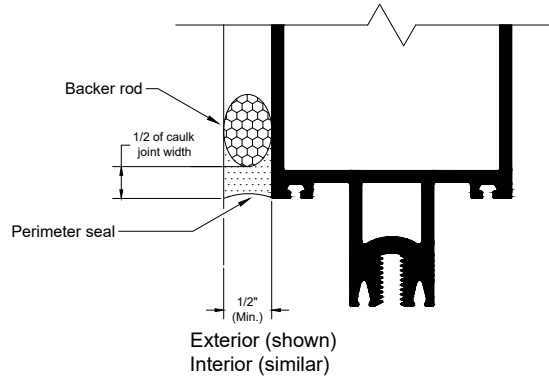
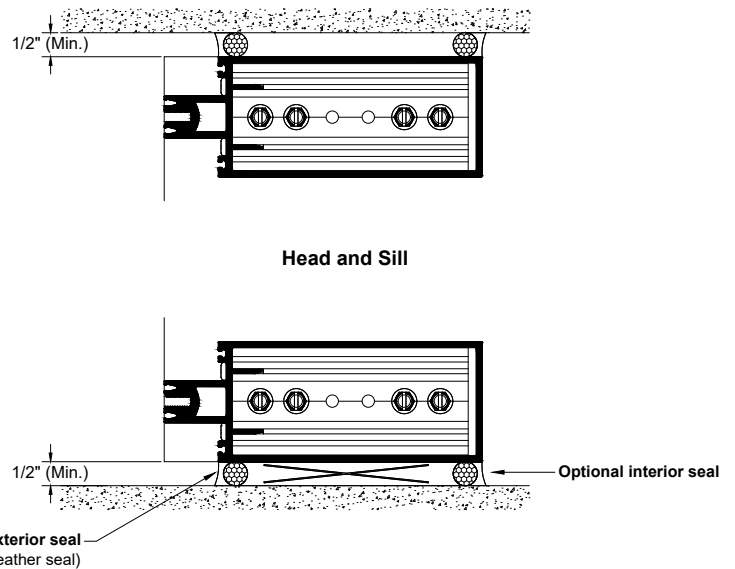
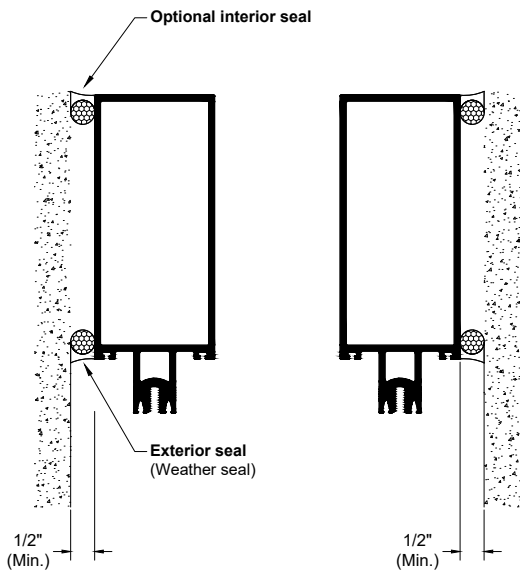

Fig.34.2



NOTE: Exterior and Interior perimeter seals must run continuous full perimeter of framing.
Fig.34.3

GLAZING

Step 16: Glazing Preparation

- A. Remove any debris from the glazing pockets.
- B. Trim excess silicone from edges of glazing units to allow for maximum glazing clearance.

Glazing pockets are designed to accept a variety of infill thickness. Refer to perimeter sheet available on our website.

Step 17: Install Gaskets

NOTE: Crowd gaskets toward the center of the member during installation to avoid gaps caused by relaxation of the gasket material.

- A. Install P4606 gasket into vertical and horizontal pressure plates. See Fig.35.1.

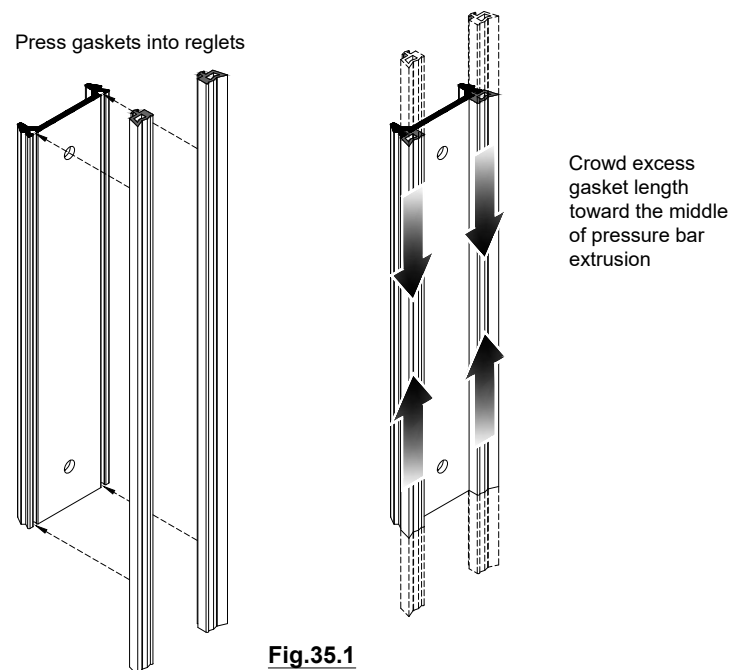

See **Step 2** pages **19-20**
for gasket cut length

GLAZING

Step 17: Install Gaskets (Continued)

- B. Install PTB108 isolator gasket into vertical and horizontal tongues. Run the isolator through the vertical splice joints. See **Fig.36.1**

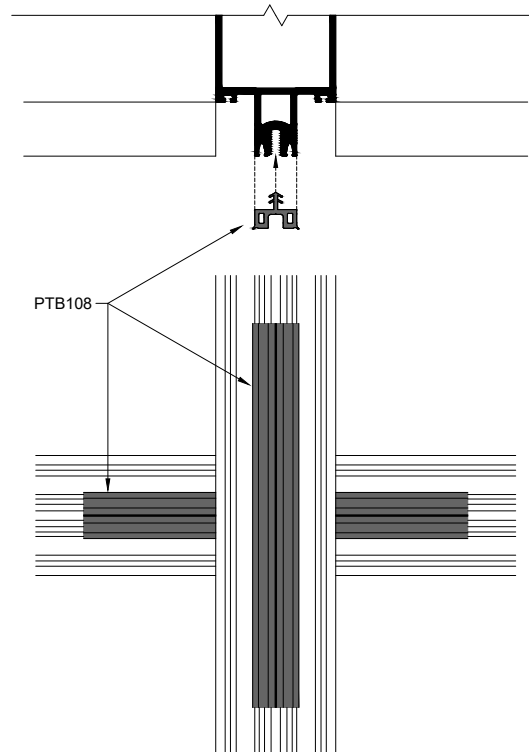

Fig.36.1

Step 18: Install Glass

NOTE: Pre-seal gaskets only in the opening to be glazed to avoid sealant curing and contamination before glass is set in place.

- A. Pull interior horizontal gaskets away from vertical gaskets and seal corners where gaskets abut. Release horizontal gasket back to its original position. See **Fig.36.2**.

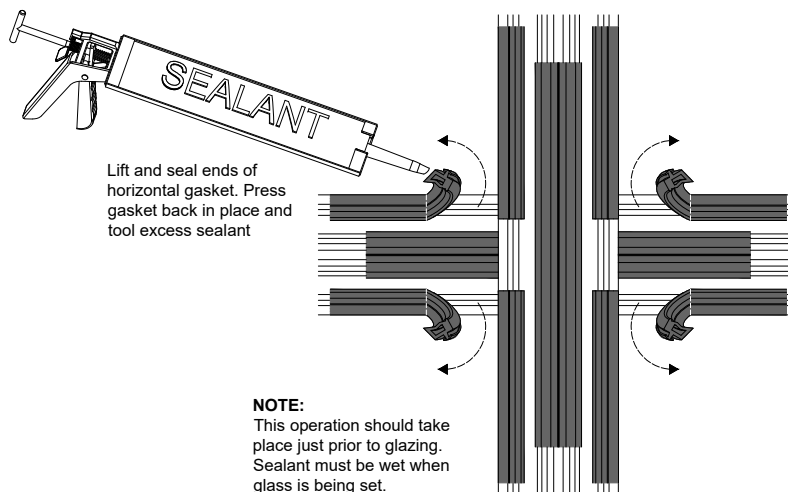

Fig.36.2

GLAZING

Step 18: Installing Glass (Continued)

- A. Install two P946 setting blocks for 1" glass at quarter points or as indicated on approved shop drawings.
NOTE: Consult the glass manufacturer for correct length and location for glass size over 40 sq. ft.
- B. Install glass onto setting blocks, positioning glass for proper bite into vertical mullions. Make sure the glass is firmly against interior gaskets before installing temporary glazing clips or pressure plates.
- C. Make sure sealant is not bridging or blocking the water flow area between the edges of the glass and the framing system.

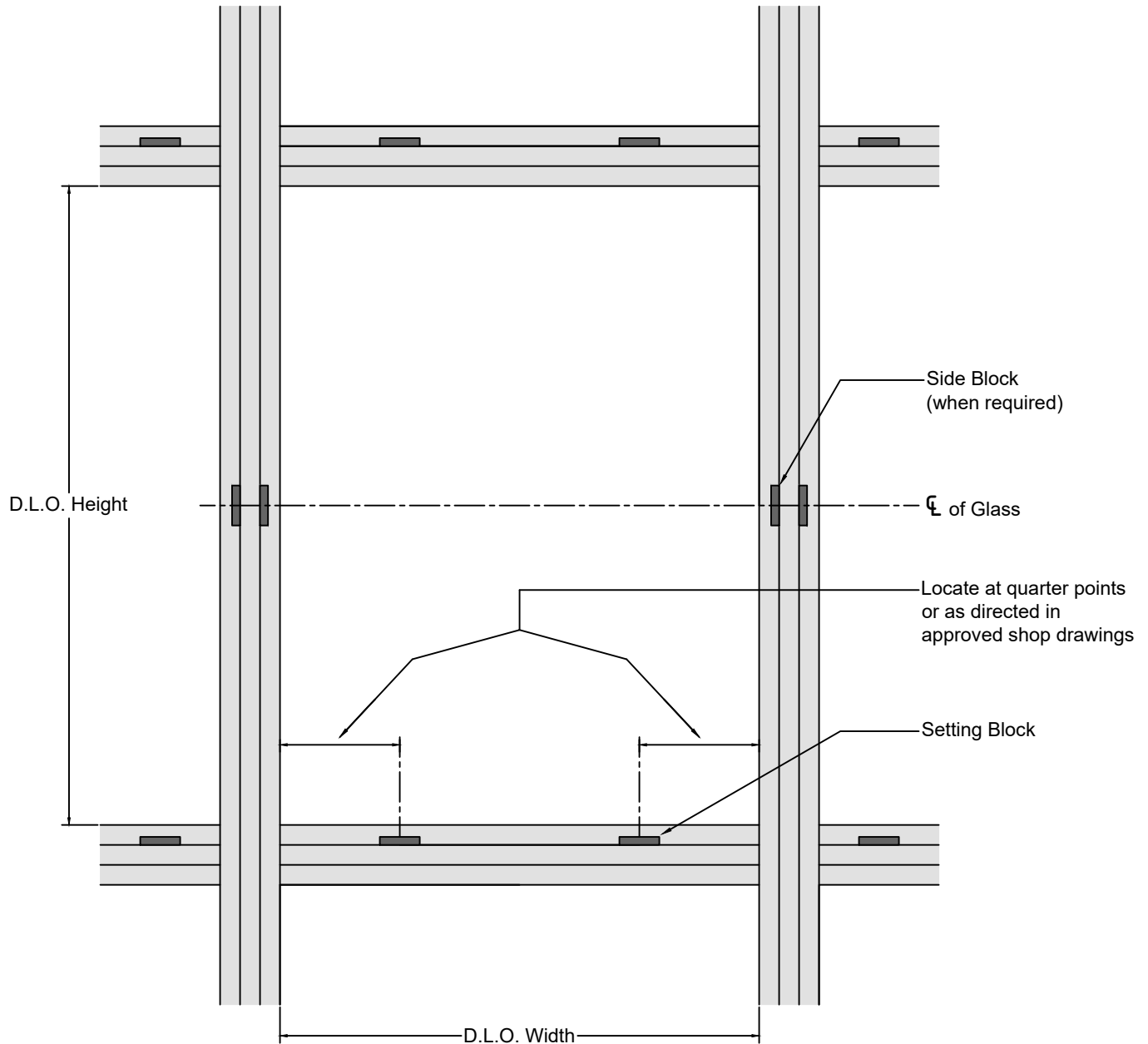

Fig.37.1

GLAZING

Step 18: Installing Glass (Continued)

E. Hold the glass in place using PTB194 temporary glazing clips. Locate clips near each corner of the glass and at mid points.

Temporary glazing retainers are intended for short term use only. Additional retainers or full length pressure plates may be required if high windload pressures are anticipated before the installation is complete.

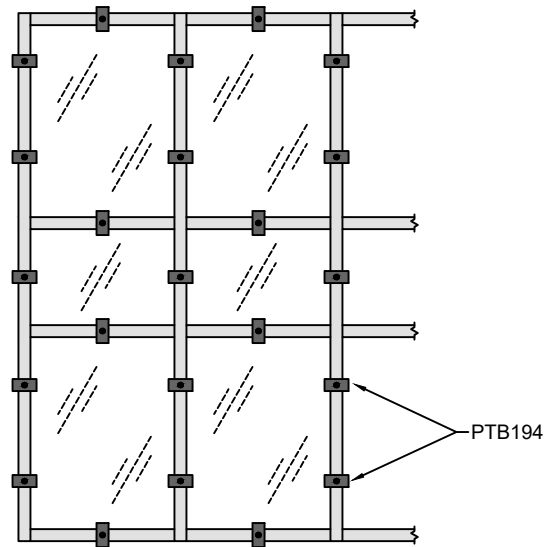

Fig.38.1

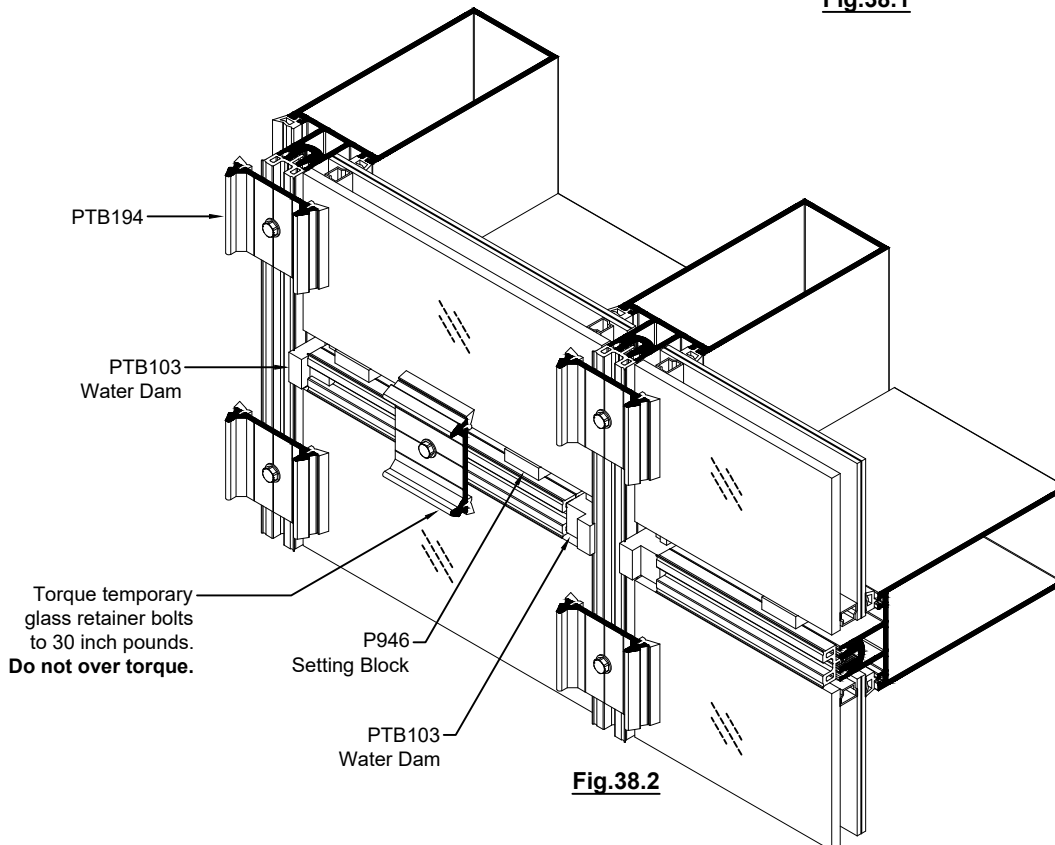

Fig.38.2

GLAZING

Step 19: Install Pressure Plates and Face Covers

- A. Remove temporary glazing retainers from verticals as required.
- B. Vertical pressure plates must be installed first. Prior to installing, apply sealant to the face of each water dam.
- C. Install the vertical pressure plates using S469 screws.
- D. Remove temporary glazing retainers from horizontals as required.
- E. Install the horizontal pressure plates using S469 screws, ensuring that weep holes are on the bottom side of the pressure plate.
- F. Ensure there are anchor holes in the pressure plates 2" max from the ends and 2" max from each horizontal/vertical intersection to maintain proper compression on the glass.
- G. Torque all pressure plate screws to 30 - 40 in-lbs. When using a cordless drill with a torque limiter, check torque periodically against a torque wrench.
- H. Install the vertical face covers using a wood block to protect the face cover.
- I. Seal the horizontal pressure plates to the vertical face covers, tooling the sealant into the joint.
- J. Install the horizontal face covers with equal gaps on each end. Make sure the weep holes in the face cover are pointing down.

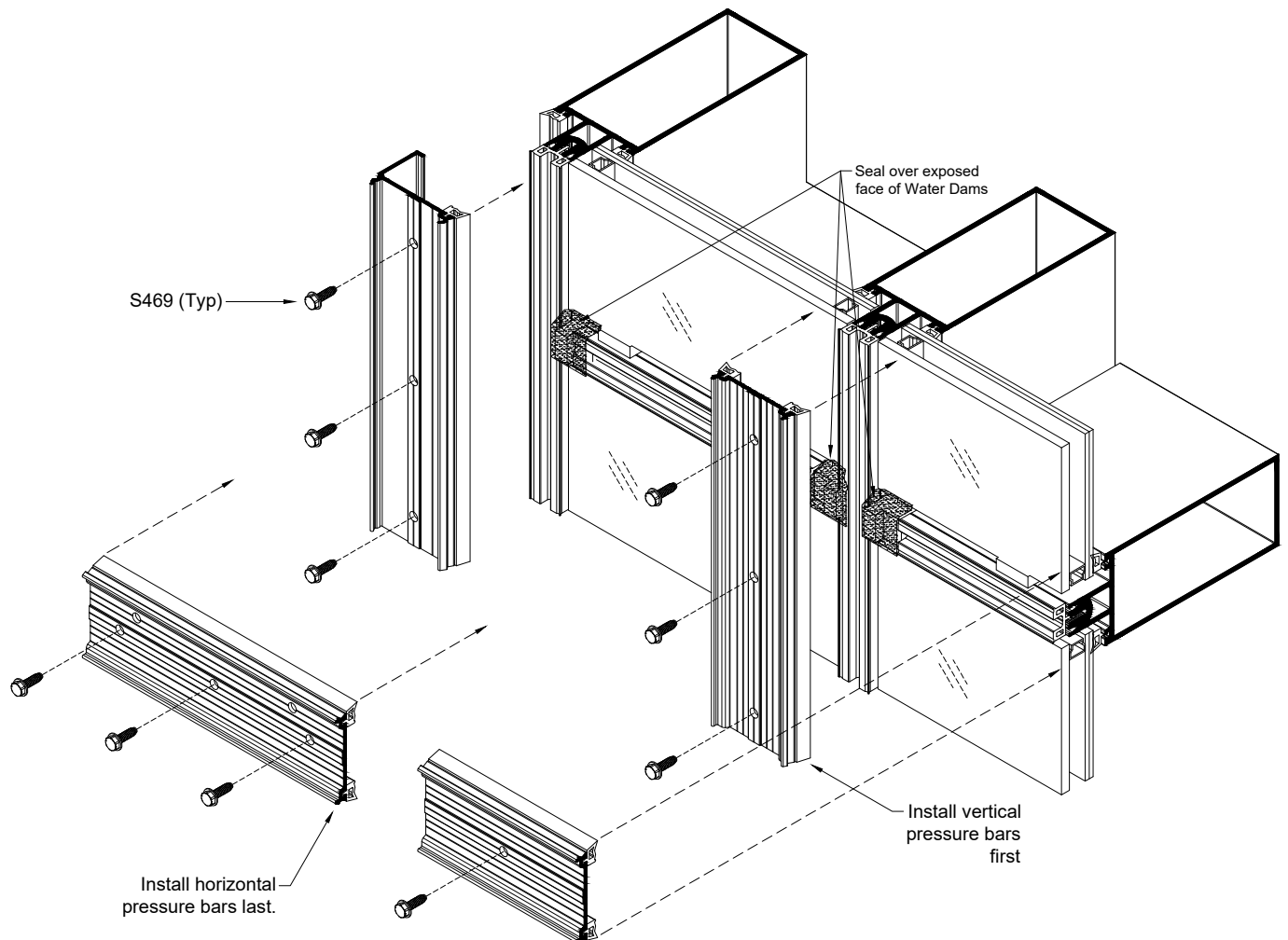

Fig.39.1

GLAZING

Step 19: Install Pressure Plates and Face Covers (Continued)

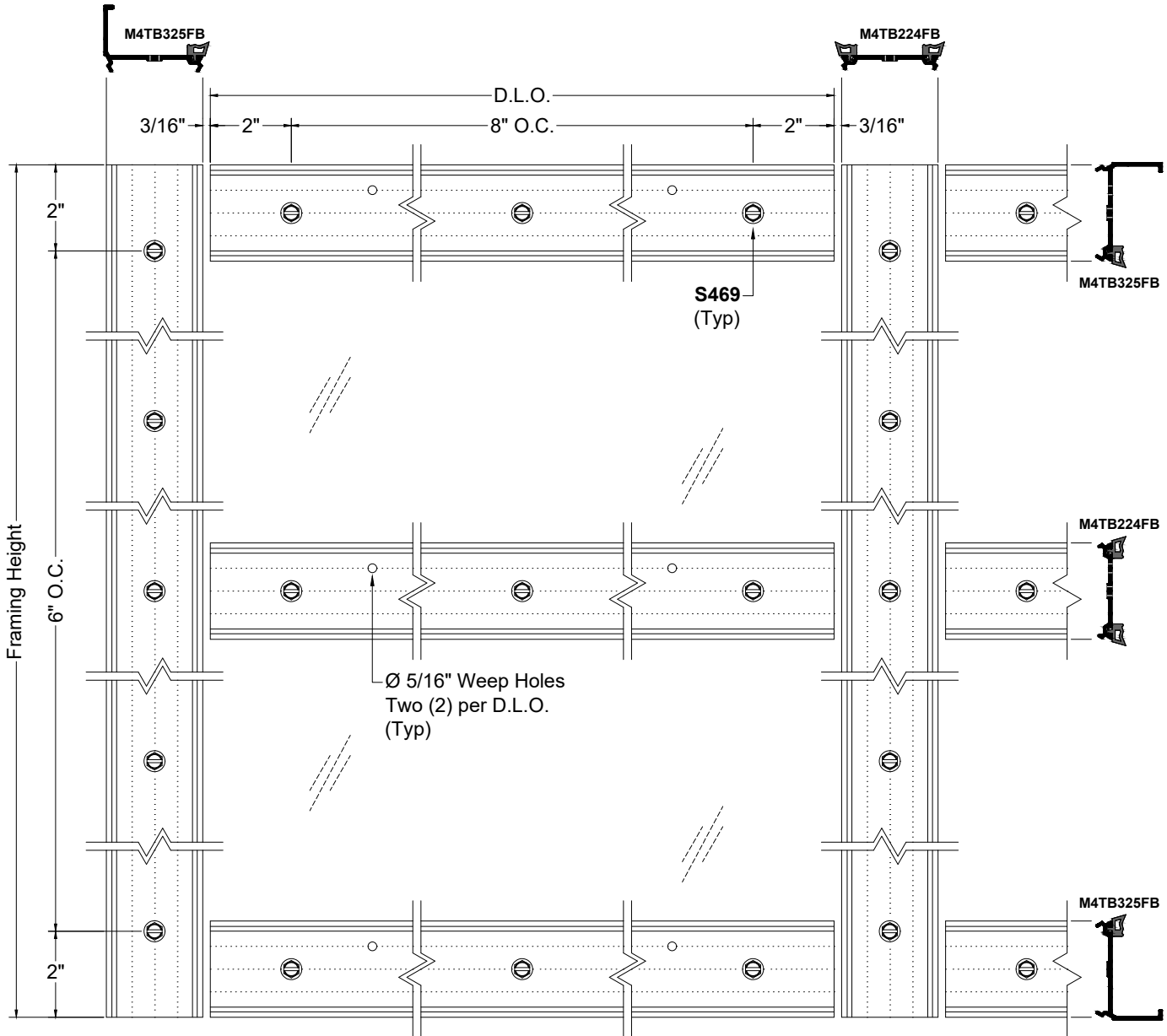

Fig.40.1
PRESSURE PLATE INSTALLATION

GLAZING

Step 19: Install Pressure Plates and Face Covers (Continued)

- H. Attach vertical pressure plate to back member with S469 screw see Fig.42.1
- I. Install the vertical face covers using a wood block to protect the face cover. Also see Fig.41.1.
- J. Attach horizontal pressure plates
- K. Seal the horizontal pressure plates to the vertical face covers, tooling the sealant into the joint. See Fig.42.2.
- L. Install the horizontal face covers with equal gaps on each end. Make sure the weep holes in the face cover are pointing down.

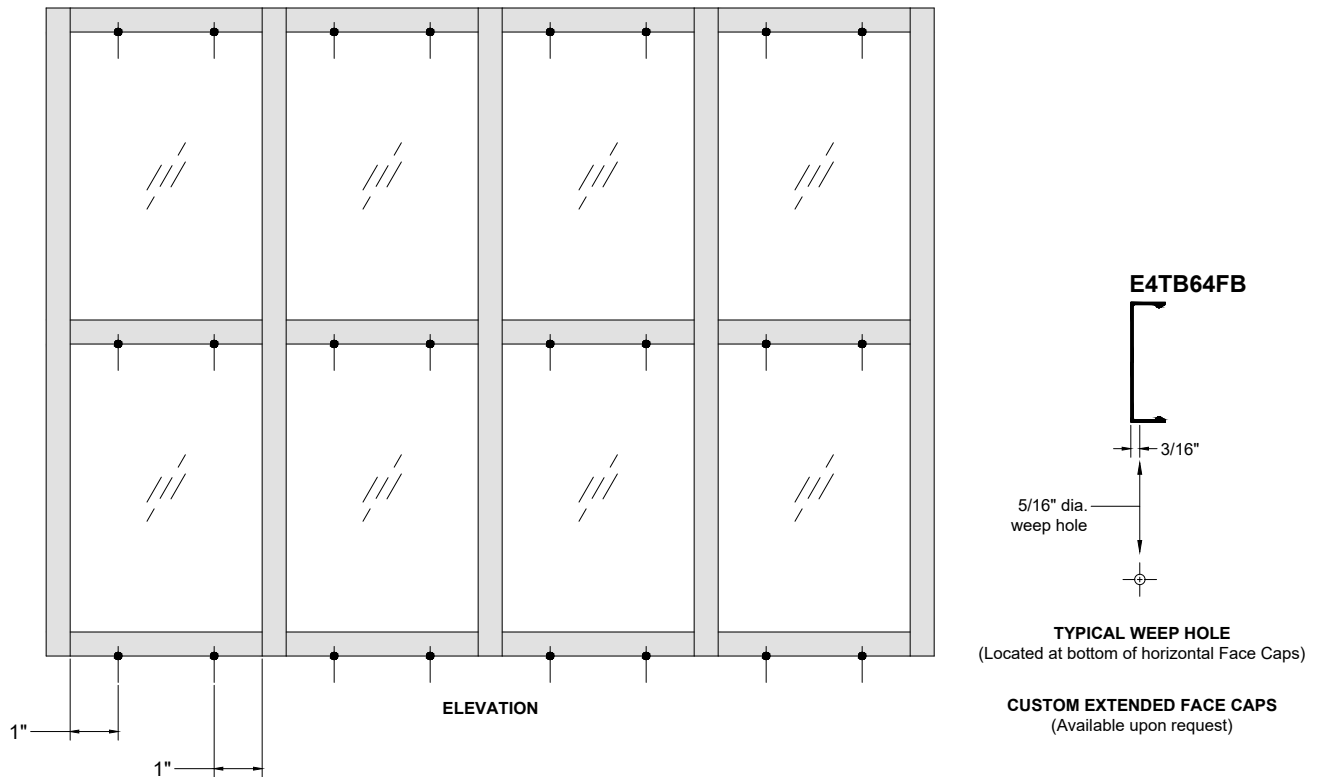

Fig.41.1

GLAZING

Step 19: Install Pressure Plates and Face Covers (Continued)

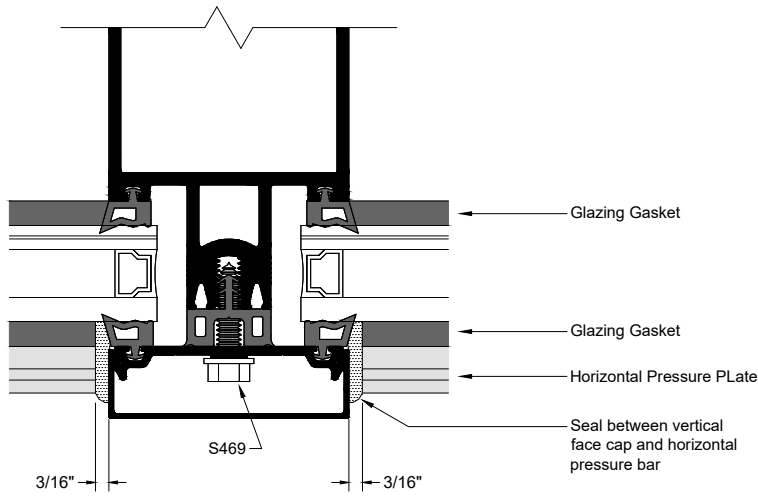

Fig.42.1

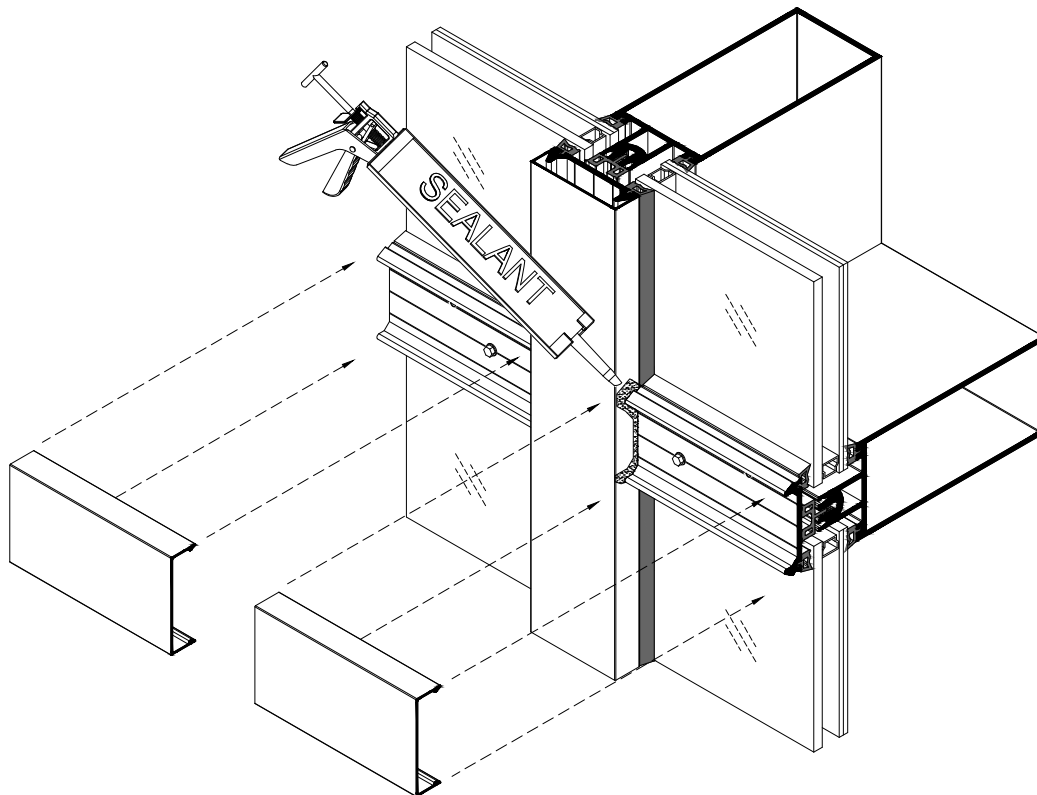

Fig.42.2

GLAZING

Step 19: Install Pressure Plates and Face Covers (Continued)

M. Pressure plate and face cap installation.

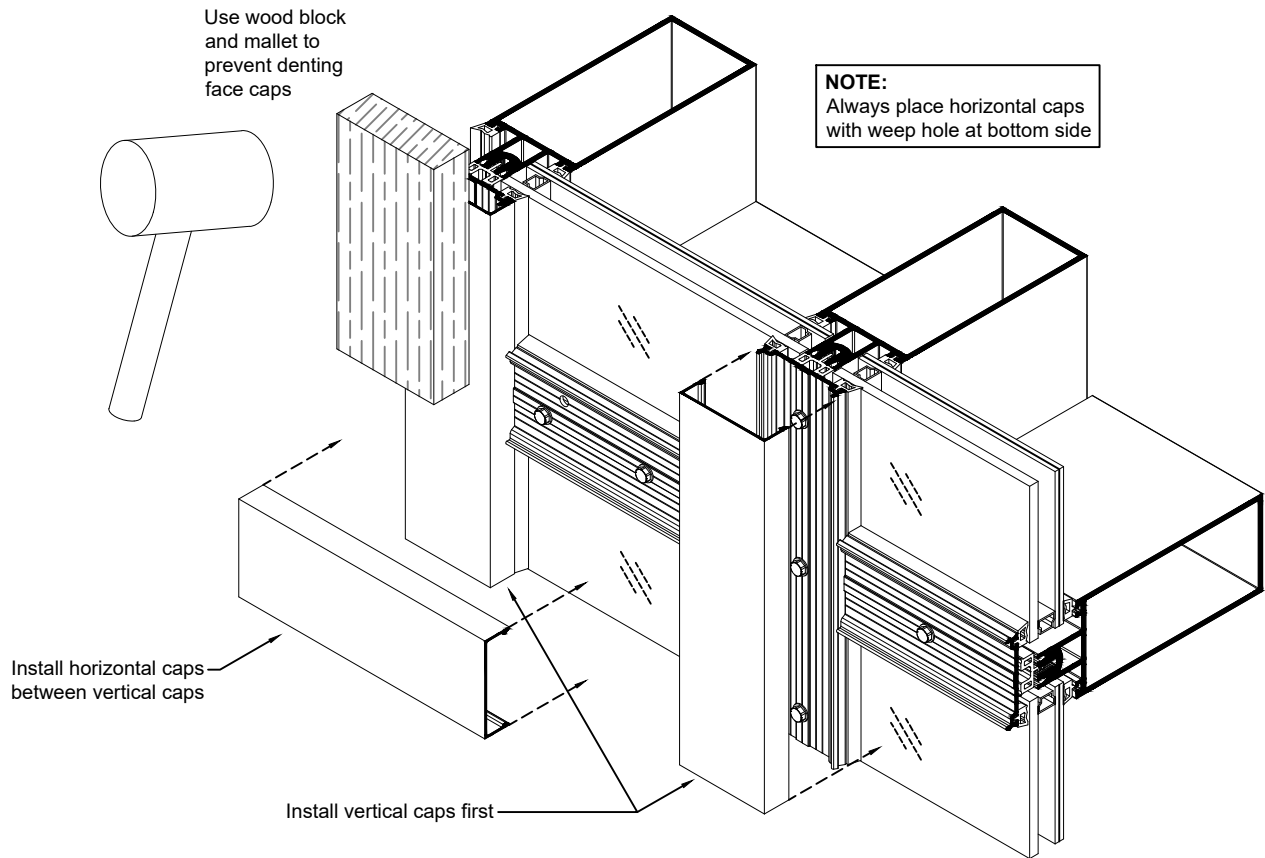

Fig.43.1
FACE CAP INSTALLATION

ENTRANCE FRAMING

ENTRANCE FRAMING

- A. All door framing is shipped fabricated from the factory. Curtain wall frames can be installed in the field prior to installing the doors.
- B. Curtain wall verticals and door subframes run to floor. Bed verticals in sealant and anchor to building per approved shop drawings. See **Fig.44.1** and **Fig.44.2** for possible anchoring methods.
Always refer to approved shop drawings for specific requirements.

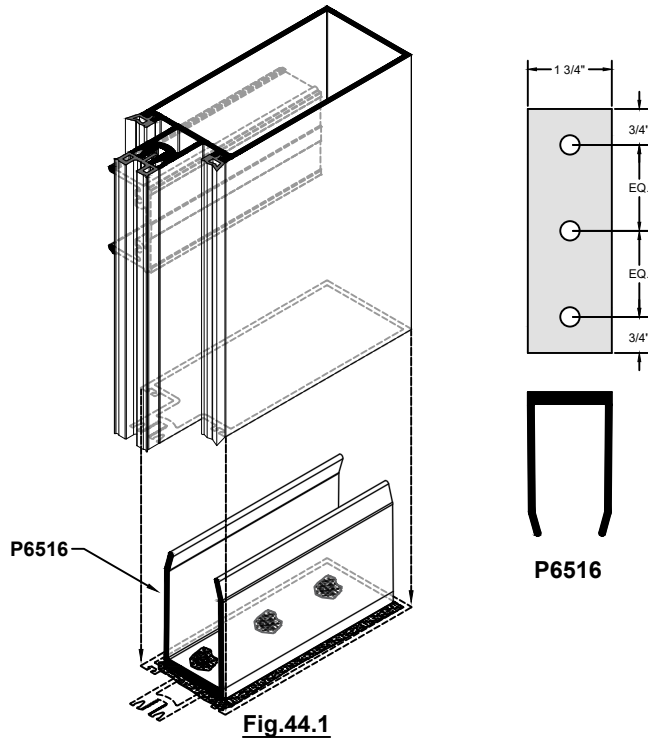

Fig.44.1

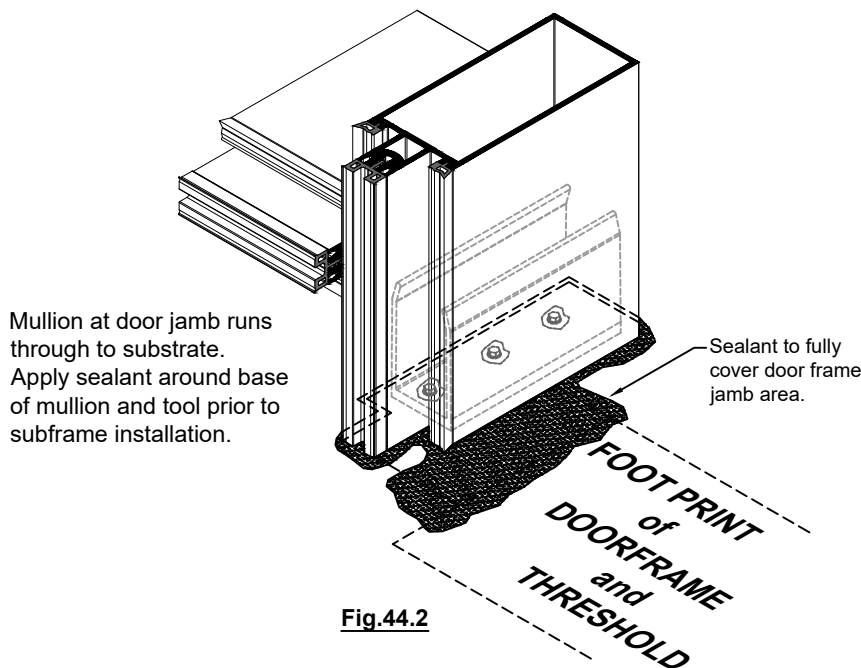

Fig.44.2

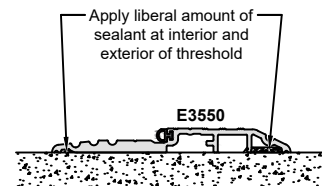

Fig.44.3

ENTRANCE FRAMING

ENTRANCE FRAMING (Continued)

C. SUBFRAME INSTALLATION

- Prep the curtain wall frame with pocket closures or as detailed on approved shop drawings.
- Prior to installing the subframe, lay down a bed of sealant where the threshold will be installed. See **Fig.45.2** and **Fig.45.3**.
- Install subframe onto curtain wall mullion, shimming equally from side to side. Attach subframe per approved shop drawings. Seal joint between subframe and curtain wall.
- Seal the top of the jamb subframe as shown in **Fig.45.3**.
- Attach threshold to building per approved shop drawings.
- Install door per Tubelite's Entrances and Frames Installation Manual.

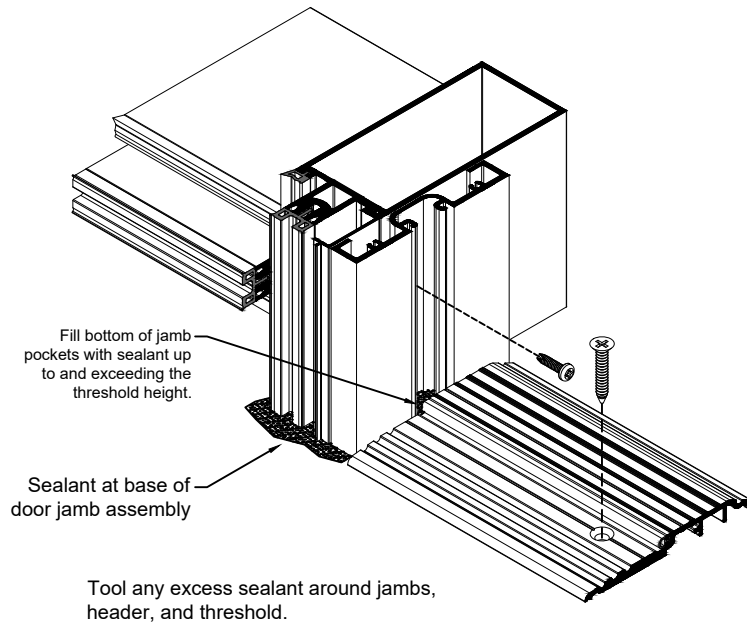
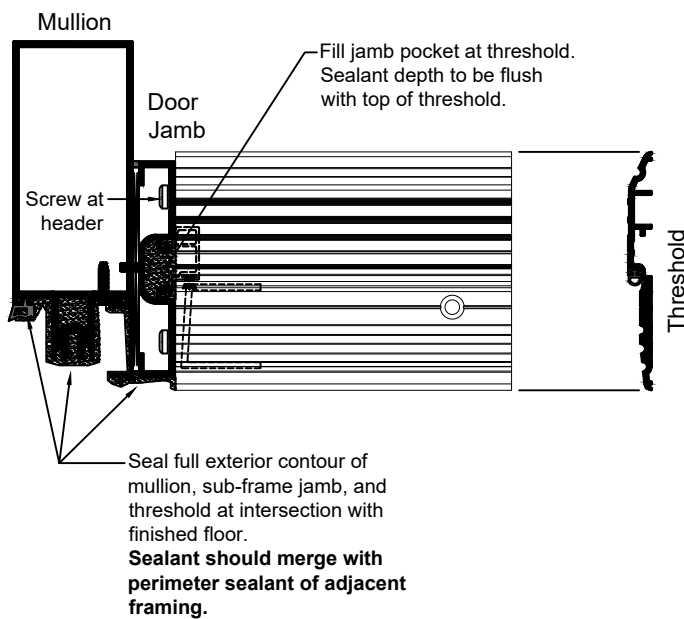

Fig.45.1



Seal full exterior contour of mullion, sub-frame jamb, and threshold at intersection with finished floor.
Sealant should merge with perimeter sealant of adjacent framing.

Fig.45.2

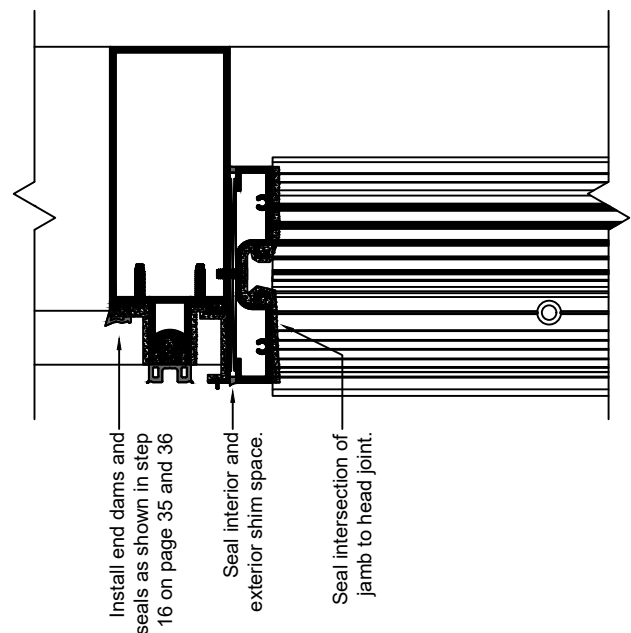

Fig.45.3

REGLAZING

REGLAZING

- A. Reglazing is done from the exterior.
- B. Carefully remove face covers surrounding the lite to be removed.
- C. Remove vertical and horizontal pressure plates adjacent to affected lite.
- D. Temp surrounding glass in place with PTB194 temporary clips per Step 18, page 39.
- E. Remove lite of glass and gaskets from opening. Clean debris and sealant from the glass pocket and glazing reglets.
- F. Install new glass in opening per Steps 16 through 18, pages 36 through 44.

TRANSITION GLAZING

TRANSITION GLAZING

- A. Install vertical adaptors first, overlapping an equal amount into each glazing pocket. When adaptors are located at vertical mullion splices, discontinue adaptor at the splice. insert a backer rod into the gap and seal thoroughly.
- B. Install horizontal adaptor with equal gaps on each end. Notching around shear block screws may be required.
- C. Seal all joints between the vertical and horizontal adaptors.
- D. Using Dow 995 seal adaptors into place.

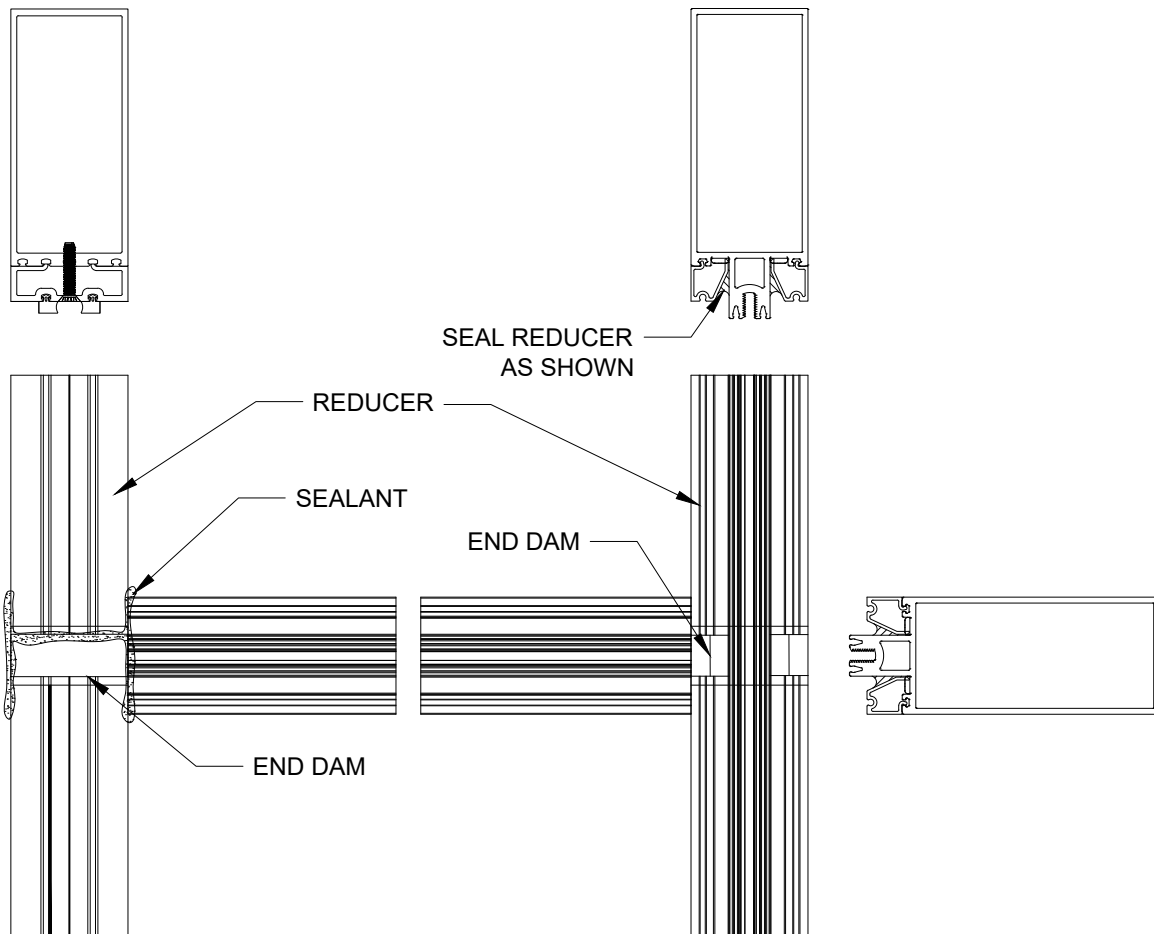

CORNERS

REGLAZING

- A. Attach E4TB52 captured mullion adaptor to the back member using S211, spaced 18" on center.
- B. Install horizontals to corner mullion.
- C. install water dams as noted in Step 15.
- D. Attach glazing gaskets and isolator gaskets and seal as noted in steps 19 and 20.
- E. Install glass, pressure plates, and face covers per steps 18 and 21.

