

# Tubelite® TU24650 Storefront

*Dual cavity pour and debridge  
ultra-thermal barrier*

Tubelite's dual cavity pour and debridge ultra-thermal barrier storefront line has been expanded and enhanced with the addition of TU24650 Series 2" x 6-1/2" profiles.

The dual cavity pour and debridge ultra-thermal barrier decreases U-Factors and increases CRF by over a single P&D pocket when using the same size and type of insulated glass. Azon's Lancer® mechanical lock provides long-term resistance to shrinkage of the polyurethane barrier. The glass plane matches that of our 4-1/2" system depth for a pleasing reveal on the exterior and interior sides of the frame. A wide variety of standard anodized and painted colors are available to complement any project with warranted protection, as well as street appeal.

Our TU24650 Series Storefront products are subjected to thorough testing by an independent laboratory, ensuring that you get the highest quality storefront framing products that the industry has to offer.

**ThermalBlock**  
HIGH-PERFORMANCE THERMAL FRAMING

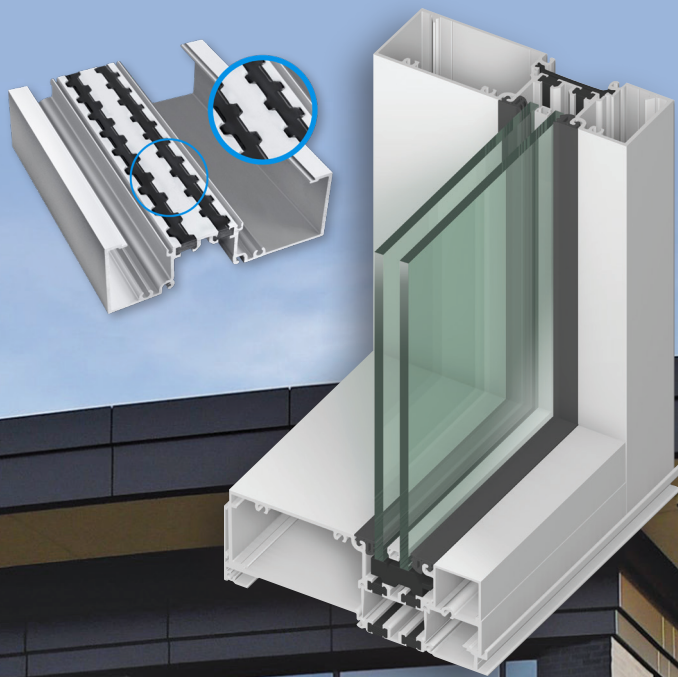

**400TU High Performance  
Thermal Curtainwall**

**Thermal Entrances**

ALSO  
USED  
WITH

*TU24650, Finish: 6P- Quaker Bronze; Project: Richard L. Postema Family Clubhouse;  
Ann Arbor, MI; Architect: UM-Facilities & Operations AEC / Partners & Sirny Architects;  
Photographer: Melanie Maxwell / The Ann Arbor News*

**TUBELITE**  
DEPENDABLE

LEADERS IN ECO-EFFICIENT STOREFRONT,  
CURTAINWALL AND ENTRANCE SYSTEMS

# Tubelite® TU24650 Storefront

Dual cavity pour and debridge ultra-thermal barrier

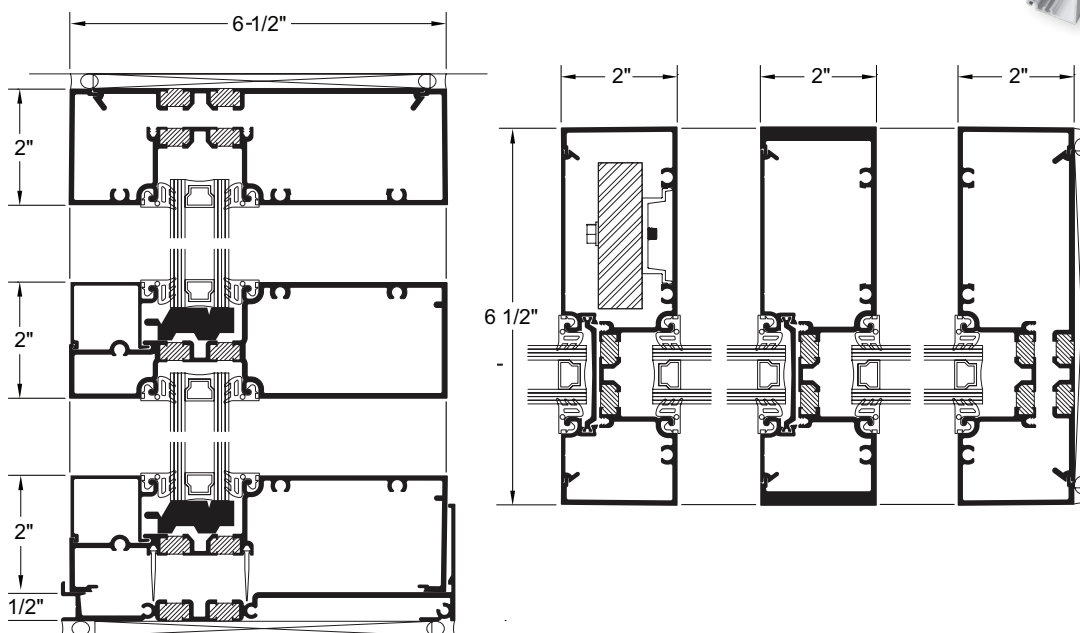
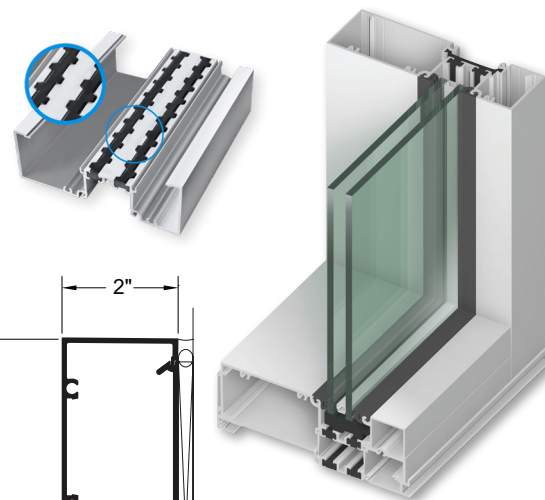

### System Features:

- TU24650 Series Storefront is recommended for use on taller ground floor applications and can span openings up to 14 feet high without steel reinforcing. Framing has 1/2" bite for use with glass or panels up to 1" thick. Verticals can be steel-reinforced for high performance against strong wind loads. Tubelite 3700 Series operable windows can be glazed into the storefront framing pocket for natural ventilation.
- This system has dual cavity pour and debridge ultra-thermal barriers for high performance, but is also available as T24650 single pour and de-bridge thermal system, or as E24650 non-thermal framing.
- Members can be assembled using screw spline or clip joinery, and framing is compatible with Tubelite's Medium and Wide Stile Thermal=Block® Doors.
- Our TU24650 Series Storefront products are subjected to thorough testing by an independent laboratory, ensuring that you get the highest quality storefront framing products that the industry has to offer.

Performance Test Standards	
<b>Air Performance</b>	ASTM E 283
<b>Water</b>	AAMA 501 and ASTM E 331
<b>Structural</b>	ASTM E 330
<b>Thermal</b>	AAMA 1503
<b>Thermal Break</b>	AAMA 505 and AAMA TIR-A8
<b>Acoustical</b>	AAMA 1801 and ASTM E 1425

### Tubelite® TU24650 Storefront Product Specifications

**Application:** Low to mid-rise commercial buildings including retail, office, healthcare, schools, etc.

**Description:** 2" x 6-1/2" dual P&D outside or inside flush glazed storefront, front set glass.

Face Width:	Overall Depths:	Glass Thickness:	Air Infiltration:	Dynamic Water:	Structural:	U-Factor**:	CRF:	Acoustic:	Outside HVHZ Approved:
2"	6-1/2"	1" std.	0.06 CFM/Ft.2 @ 6.24 PSF	12 PSF	30 PSF – Design 45 PSF – Overload	0.32 - Thermally Broken	Frame 75 Glass 70	31 STC 25 OITC	YES FL# 20393.1

\*\* U-Factor per NFRC 100: COG = 0.24 with warm edge spacer, 1-3/4" x 4-1/2" non-thermal frame.  
Refer to the U-Factor table at: [www.tubeliteinc.com/products/storefront/thermalblock-tu24650/](http://www.tubeliteinc.com/products/storefront/thermalblock-tu24650/) for other glass makeups and configurations.

DISCLAIMER: Tubelite takes no responsibility for product selection or application, including, but not limited to, compliance with building codes, safety codes, laws, merchantability or fitness for a particular purpose; and further disclaims all liability for the use, in whole or in part, of this Technical Guide in preparation of project specifications and/or other documents. Technical Guides are subject to change at any time, without notice, and at Tubelite's sole discretion. ©2017 Tubelite Inc.

050621