

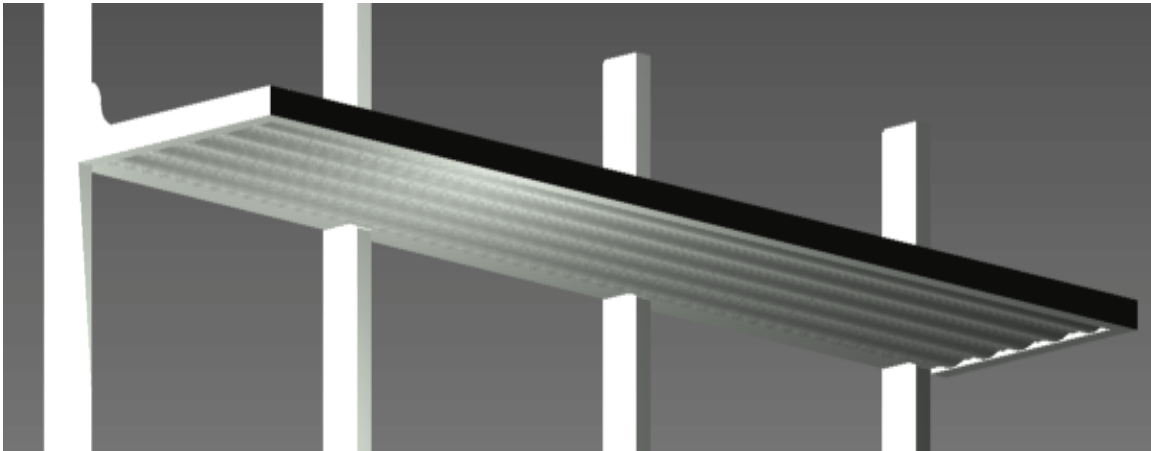

Interior Daylighting Lightshelf

Fabrication, Assembly & Installation Instructions



TUBELITE®
DEPENDABLE

*LEADERS IN ECO-EFFICIENT STOREFRONT,
CURTAINWALL AND ENTRANCE SYSTEMS*

Table of Contents

General Construction Notes	3
Basic Members & Fasteners.....	4
Fabrication/Assemble/Installation:	
<u>Fabrication</u>	
Fabrication IN-RIGGER.....	7
Fabrication LITEWAVE.....	9
Fabrication TRIM CAP.....	10
<u>Installation</u>	
Installation IN-RIGGER	8
Installation LITEWAVE.....	9
Installation TRIM CAP.....	11
Maintenance	15
Cleaning and Maintenance Guide – Reference Website.....	15
Maintenance Guide	15
Cleaning and Maintenance Guide for Flurocryl®Coatings – Hardcopy.....	15

GENERAL CONSTRUCTION NOTES

1. These drawings and notes cover typical conditions for this product. Due to individual job requirements it is necessary to refer to Tubelite's final distribution drawings for supplemental information not covered by these instructions. Any conflict or discrepancies must be clarified through Tubelite's Engineering Department prior to execution.
2. All framing shall be erected plumb and true in proper alignment and relation to established lines and grades.
3. Any discrepancies found between Tubelite's final distribution drawings, these drawings and notes, and actual field conditions must be brought to the attention of Tubelite's Engineering Department for recommendation prior to execution.
4. Materials stored at the job site must be kept in a safe place removed from possible damage by other trades. Store off the ground. Cardboard or paper wrapped materials must be kept dry. Check arriving materials for quantity and keep record of where various materials are stored.
5. All field welding must be adequately shielded to avoid any weld splatter on either aluminum or glass. Results will be unsightly and may be structurally unsound. Advise general contractor and other trades accordingly.
6. Coordinate protection of installed work with general contractor and/or other trades.
7. Coordinate sequence of other trades which affect framing installation with the general contractor (e.g. fire proofing, back up walls, partitions, ceilings, mechanical ducts, convectors, etc.).
8. General contractor should furnish and guarantee bench marks, offset lines and opening dimensions. These items should be checked for accuracy before proceeding with erection. Make certain that all adjacent substrate construction is in accordance with the contract documents and/or approved shop drawings. If not, notify the general contractor in writing before proceeding with installation, since this constitutes acceptance of work by other trades. If pre-setting of anchorage is required, coordinate with the general contractor and supervise the location.
9. Review shop drawings to become familiar with project-specific conditions.
10. All materials to be installed plumb, level and true with regard to established bench marks and column center lines established by the general contractor and checked by the slope wall contractor.

BASIC MEMBERS & FASTENERS

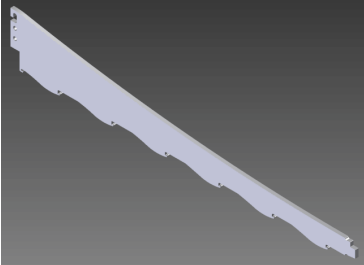
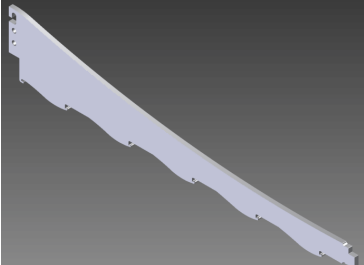
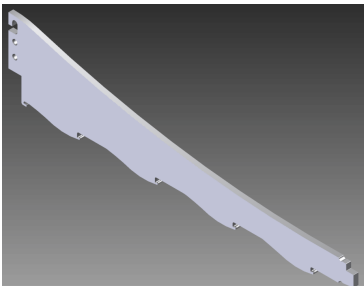
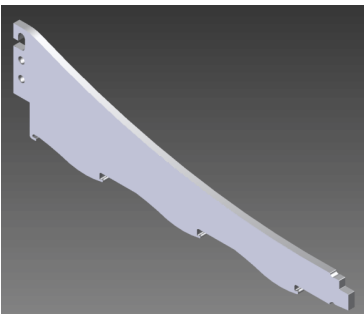
PARTS/SHAPES	Description	Part No.
	LiteWave Aluminum Extrusion	E6405
	In-Rigger 36" (for storefront application)	P6411-0R
	In-Rigger 30" (for storefront application)	P6412-0R
	In-Rigger 24" (for storefront application)	P6407-0R
	In-Rigger 18" (for storefront application)	P6413-0R

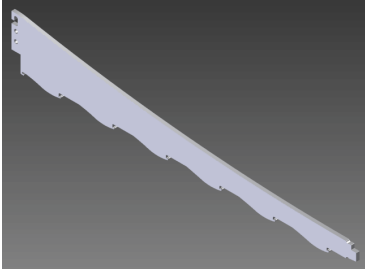
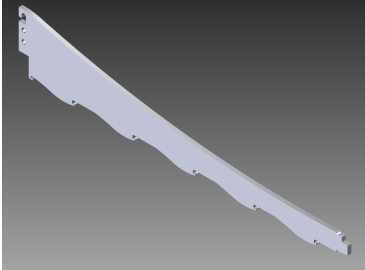
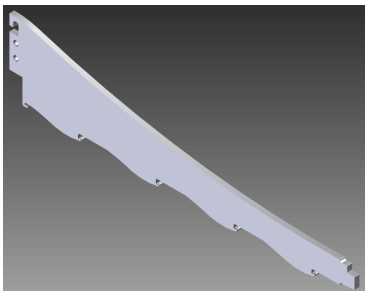
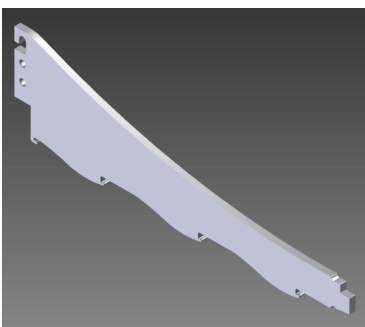
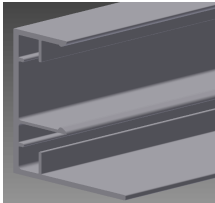
PARTS/SHAPES	Description	Part No.
	<p>In-Rigger 36" (for curtainwall application)</p>	<p>P6417-0R</p>
	<p>In-Rigger 30" (for curtainwall application)</p>	<p>P6416-0R</p>
	<p>In-Rigger 24" (for curtainwall application)</p>	<p>P6415-0R</p>
	<p>In-Rigger 18" (for curtain application)</p>	<p>P6414-0R</p>
	<p>Cap, Trim, Aluminum Extrusion</p>	<p>E6403</p>

PARTS/SHAPES	Description	Part No.
	Transition 'I' Aluminum Extrusion	E6404
FASTENERS/TOOLS	Description	Part No.
	Kit (3) PCS of S370 - Screw, 3/8-16 X 1" Button Socket Head	P6405
	S200 - Screw, #8-32 x 3/8" Flat Head Phil Type F	S200
	Kit - (4) PCS of S200 - Screw #8-32 x 3/8" Flat Head Phil Type F & (2) PCS P6409 Corner Key (.312 long)	P6408
	Tool - Drill Fixture – In-Rigger (Optional) (for storefront application)	P6410
	Tool - Drill Fixture – In-Rigger (Optional) (for curtainwall application)	P6418

Overview/Fabrication/Assembly/Installation

FABRICATION – In-Rigger

Fab Step #1a: Determine Horizontal Window DLOs (Day Light Openings);

Fab Step #1b: Determine In-Rigger location & LiteWave Cut Length.

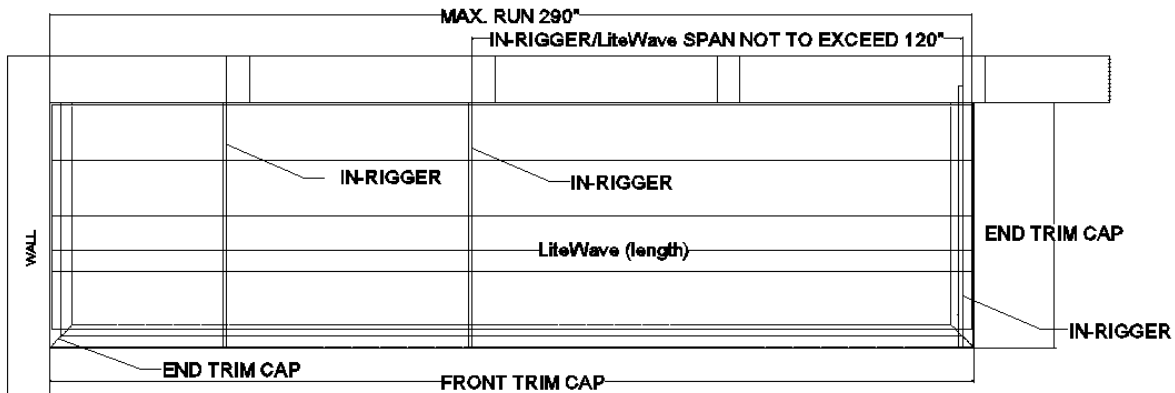

Fab Step #1c Locate & Drill In-Rigger Mounting Holes - Using Drill Fixture locate & pre-drill 1/4" locator holes figure 1&2:

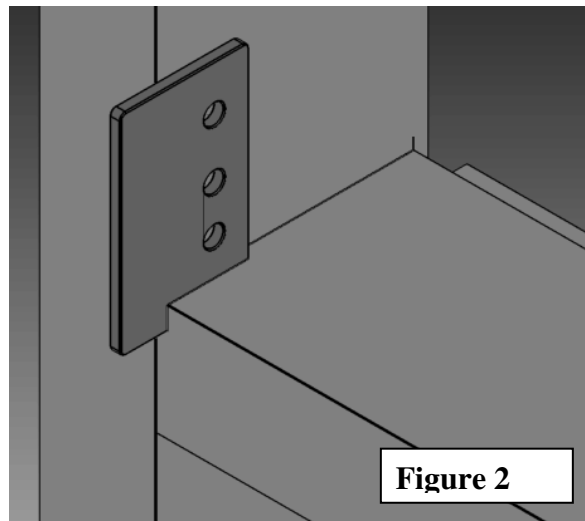
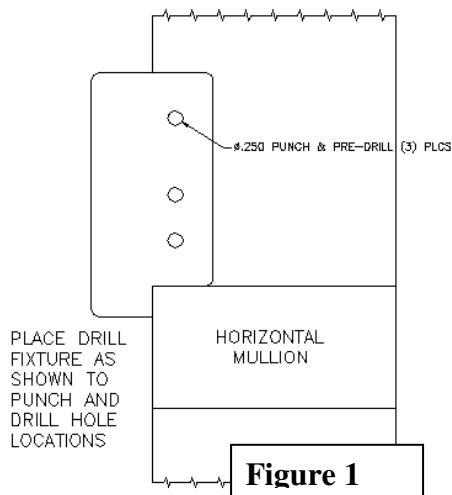

- Drill and 3/8-16 tap (3) places in mullion for In-Rigger mounting screws:

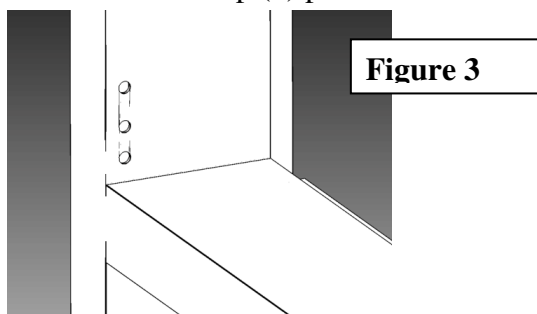

INSTALLATION – In-Rigger

Install Step #1a: Locate (1) In-Rigger per vertical mullion not to exceed 120” max. span and Fastener Kit (P6408)

Install Step #1b: Install (1) fastener (P6405) into top tapped hole, allowing ½” clearance for In-Rigger – as shown figure 4& 5.

Install Step #1c: Position & hang In-Rigger onto fastener as illustrated figures 5, & 6.

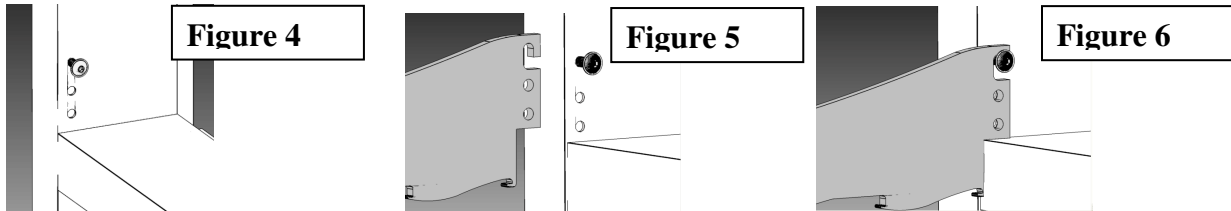

Install Step #1d: Install remaining (2) fasteners into In-Rigger. Tighten, but not over-tighten causing thread strip out.

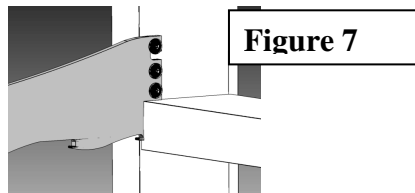

FABRICATION - LiteWave

Fab Step #2: Cutting E6405 LiteWave to length

- Cut to predetermined length required (per step #1 & 2 above) length equals In-rigger hang on location to furthest opposite end location (not to exceed max extrusion length of 290") Important - LiteWave extends beyond In-Rigger - not to exceed 1/2".

NOTE: Linear alignment of single and multiple lightshelf units is very important. It is recommended that alignment equipment be used to insure accuracy. Complete fabrication and installation instructions should be reviewed prior to any fabrication, assembly or installation activities.

For length of LiteWave extrusion (approx 290" max.), measure DLOs and spans to determine optimum linear spans, not to exceed 120" between In-Riggers.

INSTALLATION - LiteWave

Install Step #2a: Install LiteWaves Install LiteWave (E6405)

- Using LiteWaves cut to predetermined lengths (Fabrication Steps) locate first LiteWave and place it onto the (2) corresponding 'hooks' closest to the glass on the bottom side of the In-Rigger as illustrated – *figure 8*.

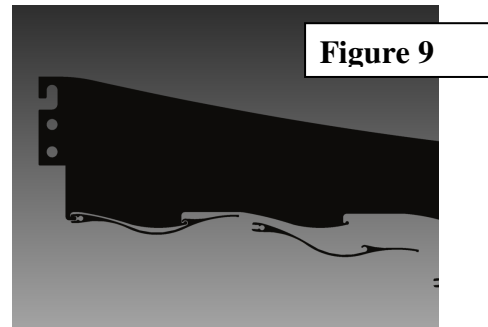
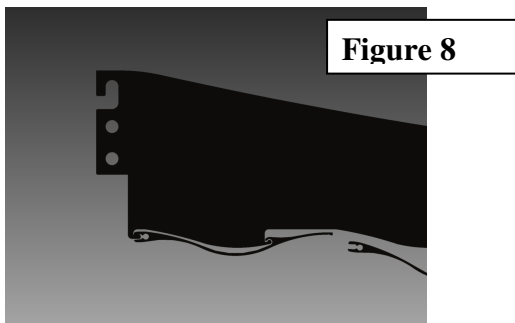

- LiteWave will hang in place on the In-Riggers while you get the next LiteWave and repeat - installed in the same manner.

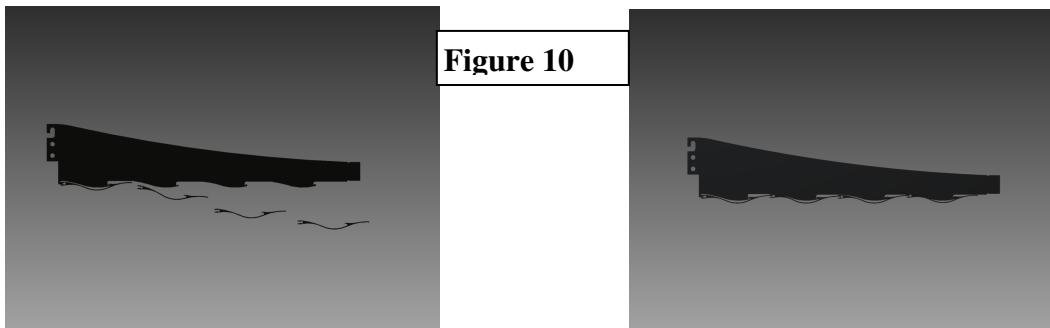

- NOTE: The last LiteWave installed may require a little additional pressure to lock into place *figures 9 & 10*. Use non-marking mallet to tap into place.

- ***Install Step #2b:*** Install LiteWaves; the last LiteWave is now in place – if the last LiteWave is loose, secure it at the outer edge of in-rigger using fastener (S200) as illustrated figures 11 & 12; drill & tap to insure proper location and secure attachment.
- **Important** - LiteWave should not extend more than 1/2” beyond In-Rigger each end.

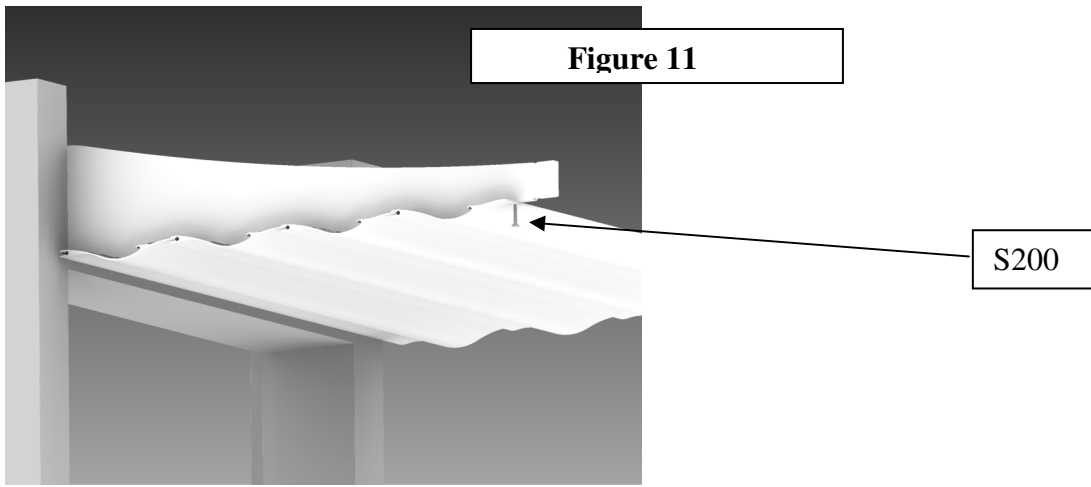

FABRICATION – Trim Cap

Fab Step #3 Trim Caps

End Trim Caps are cut to match In-Rigger depth with 45 degree cut on inside end corner (as illustrated) (these are approx. nominal dimensions; please confirm for your installation):

- 18” In-Rigger uses approximately 19-3/4” long End Cap
- 24” In-Rigger uses approximately 25-3/4” long End Cap
- 30” In-Rigger uses approximately 31-3/4” long End Cap
- 36” In-Rigger uses approximately 37-3/4” long End Cap

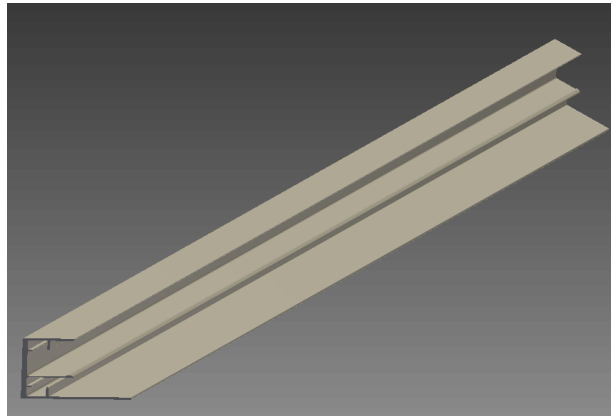
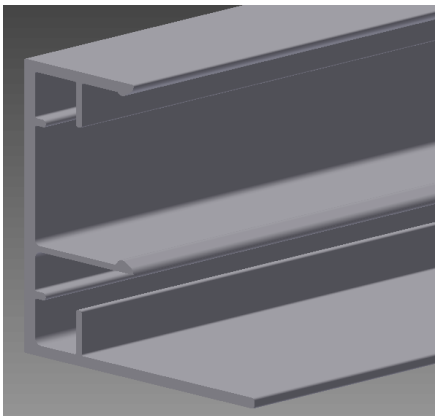

INSTALLATION - Trim Cap

Install Step #3a: (E6403)

IMPORTANT: fabricate end trim cap first, then with end trim caps located in place, measure and cut front trim cap as noted.

Place fabricated front trim cap on bench face down, insert corner keys as shown and then add end trim cap. Check corner for square-ness and fit-up. With corner together, drill two holes and install self threading screws, one in each side of front trim cap as shown, into corner key.

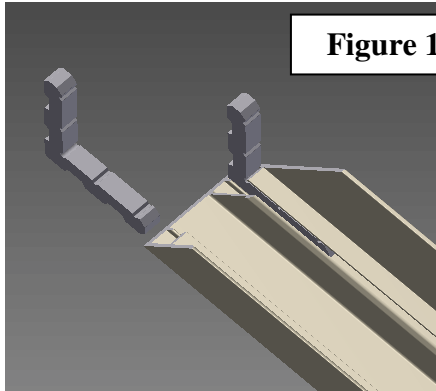

Figure 13

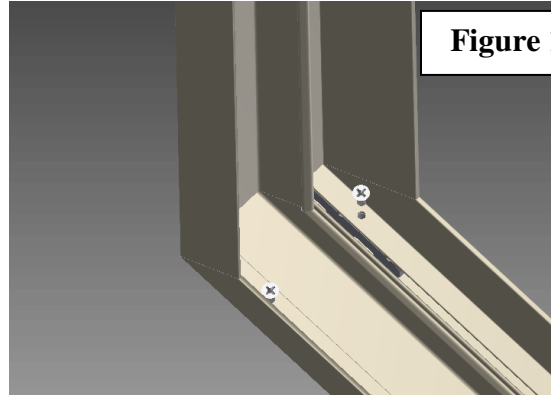

Figure 14

Drawing views of trim cap installation:

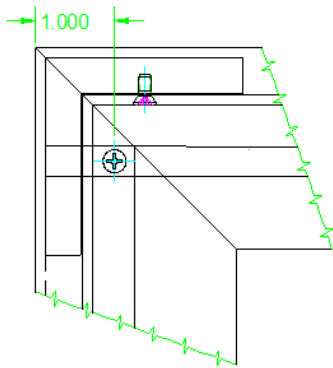
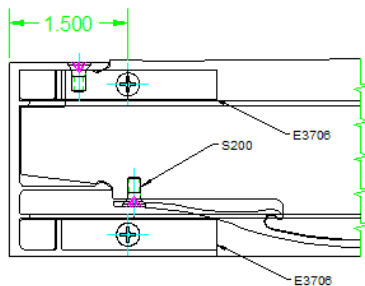
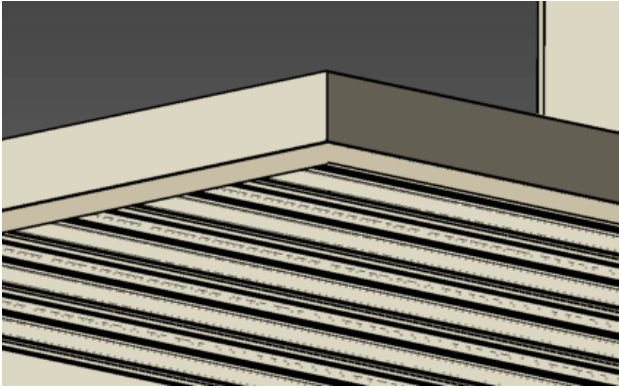
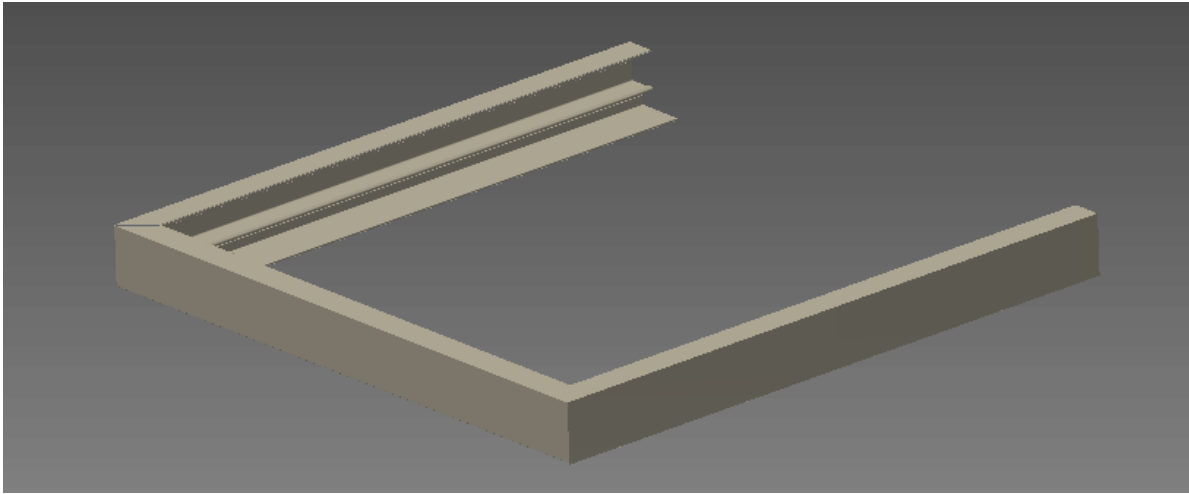

Figure 15



Install Step #3b: With end caps attached to front trim cap, locate and slide unit over LiteWave ends and into place, snapping front trim over front ends of In-Riggers.



INSURE CLEAN SHARP
CORNERS

Install Step #3c: After cap has been located into place, drill & install self threading screw (S200) through top side of cap and into In-Rigger as illustrated.

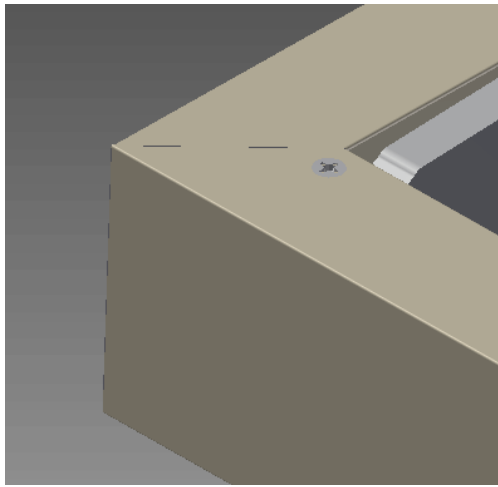
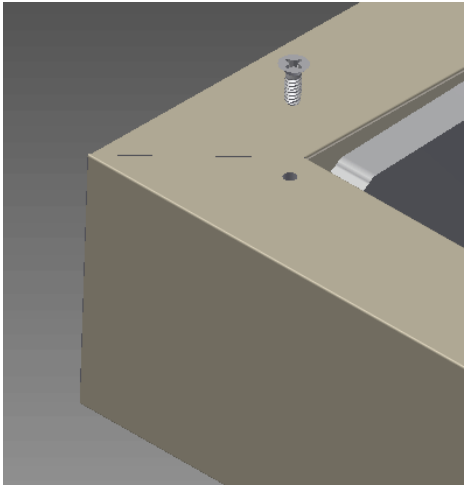

Installation considerations for corners: This illustration shows only a few common building corners configurations. Please contact Tubelite for specific fabrication and installation recommendations for your specific circumstance.

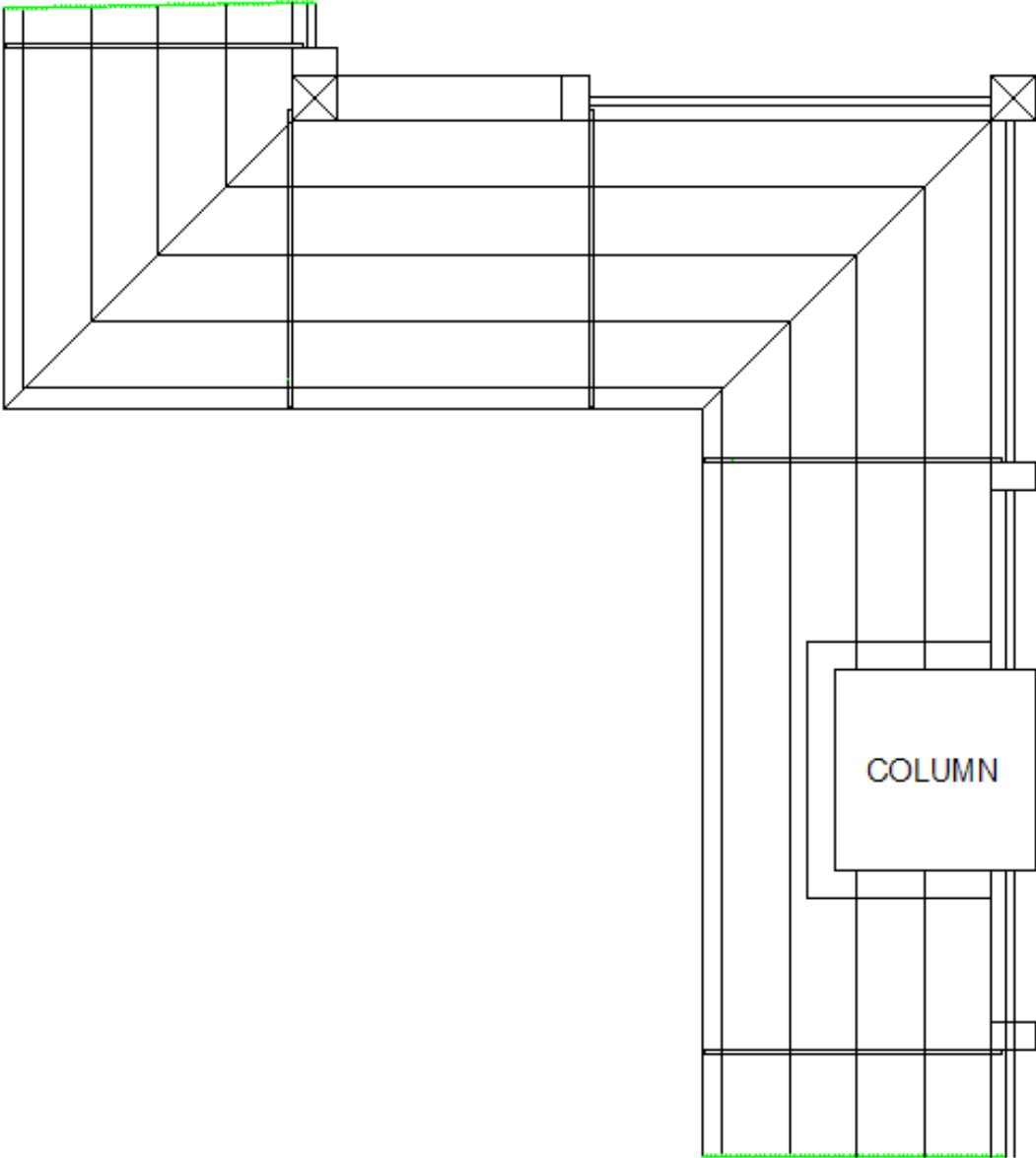

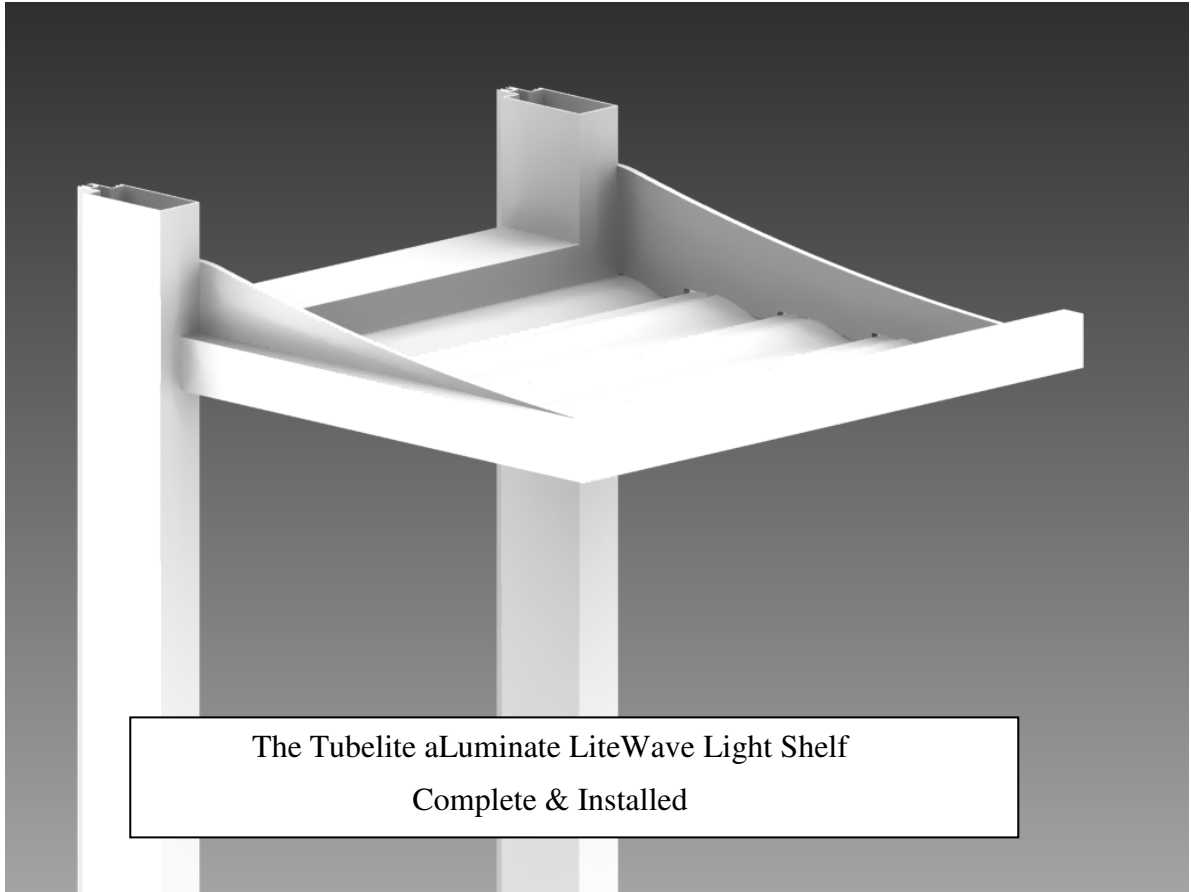

- **Cleaning and Maintenance Guide – Reference Website - Maintenance:**

http://www.paintandcolor.com/pac/pdf/Cleaning_and_Maintenance_Guide_for_Fluorocryl_Coatings.pdf (or see below)

- **Cleaning and Maintenance Guide for Fluorocryl® Coatings** In cleaning this system three precautions should be observed:

- 1) Do not use abrasives (i.e., Comet cleanser), wire brushes, or similar cleaners or tools which mechanically abrade the surface,
- 2) Prior to utilizing a household, commercial or industrial cleaning agent, the list of ingredients must be reviewed to ensure that the cleaner is free from the solvents discussed below, and
- 3) Cleaning agents should be tested in an isolated area before using on a large scale.

GROUP A: HOT OR COLD DETERGENT SOLUTIONS

A 5% solution in water of commonly used commercial and industrial detergents will not have any deleterious effect on the Fluorocryl surface. Cleaning with these solutions should be followed by a thorough water rinse. Use a soft cloth for application of this solution.

GROUP B: SOLVENTS

Most organic solvents are flammable and/or toxic, and must be handled accordingly. Read the manufacturer's Material Safety Data Sheets (MSDS). Keep away from open flames, sparks, and electrical motors. Use adequate ventilation, protective clothing, and goggles. The solvents listed below may be applied directly to the Fluorocryl surface if removed and dried within 5 minutes.

Solvent that may be used to remove non-water soluble deposits such as tar, grease, oil, and graffiti from Fluorocryl surfaces include; Alcohols - These alcohols have no permanent effect on Fluorocryl finishes: Denatured alcohol (ethanol) Isopropyl alcohol (rubbing alcohol)

GROUP C: PETROLEUM SOLVENTS AND TURPENTINE

The solvents listed below may be applied direct to the Fluorocryl surface, if removed and dried within 15 minutes: VM&P naphtha Mineral spirits

The above solvents have no permanent effect on Fluorocryl finishes

- **CHEMICAL SOLUTIONS**

Mildew: In areas subject to high humidity levels, dirt and spore deposits can permit mildew growth to occur. The following solution is recommended to remove mildew when necessary:

Laundry bleach (Clorox) at a reduction of 10 parts water to 1 part bleach.

Limit contact to 5 minutes and follow with a thorough water rinse.

Typical household cleaners that may be used directly on the Flurocyl system include: 409, Soft Scrub, Tilex, Pine-Sol & Lysol

- **SOLVENTS NOT TO USE**

The following solvents must not be utilized as cleaning agents, or components of cleaning agents – use of these solvents will result in delamination of the Flurocyl film from the aluminum substrate:

Xylene (Xylol), Toluene (Toluol), Perchlorethylene (Perclene), Trichlorethylene (Triclene), Methyl ethyl ketone (MEK), Methyl isobutyl ketone (MIBK), Ethyl acetate (Nail polish remover), Butyl acetate, Acetone, Paint/lacquer thinner, and Paint remover

- **WARRANTY**

Misuse or abuse of any cleaning agent will result in a voiding of warranty for the surface affected.